

INVERTER

New Product RELEASE

No.15-9E

Release of the 3000 r/min compatible models for the premium high-efficiency IPM motor MM-EFS series

The 3000 r/min compatible models (0.75 to 15 kW) are added to the premium high-efficiency IPM motor MM-EFS series to offer a wide variety of lineup.

Features

The MM-EFS series IPM motor provides further improved efficiency that is equivalent to IE4 (super premium efficiency) specified in the international standard IEC 60034-30.

The IPM motor can be used for applications which require high-speed rotation, contributing to energy saving.

Model

MM - EFS 11K 3

Symbol	Output	Symbol	Output
7	0.75 kW	55	5.5 kW
15	1.5 kW	75	7.5 kW
22	2.2 kW	11K	11 kW
37	3.7 kW	15K	15 kW

Symbol	Voltage class
None	200 V
4	400 V

Symbol	Rated speed
3	3000 r/min

* The motor with an 11 kW or higher capacity is designed for a direct connection only.



Motor specifications

MM-EFS]3		7	15	22	37	55	75	11K	15K
MM-EFS]34									
Compatible inverters	FR-F820/F840-]K	0.75	1.5	2.2	3.7	5.5	7.5	11	15
Continuous characteristics*1	Rated output [kW]	0.75	1.5	2.2	3.7	5.5	7.5	11	15
	Rated torque [N·m]	2.39	4.77	7.00	11.8	17.5	23.9	35.0	47.7
Rated speed [r/min]		3000							
Maximum speed [r/min]		4000							
Number of poles		6							
Maximum torque		120% 60 s							
Frame number		80M	90L	112M	132S	160M			
Moment of inertia J [x10 ⁻⁴ kg·m ²]		10.7	22.4	29.8	68.3	198	198	534	534
Rated current [A]	200 V class	3.2	6.1	8.4	14.3	21.4	28.7	37.6	51.4
	400 V class	1.6	3.1	4.2	7.2	10.7	14.4	18.8	25.7
Structure		Totally-enclosed fan-cooled type with steel framed legs (protective structure IP44*2)							
Thermal class		155 (F)							
Vibration rank		V15							
Mass [kg]		8	12	14	25	41	75		

*1 The output and rated motor speed are not guaranteed when the power supply voltage drops.

*2 Except for the shaft-through portion

Torque characteristics

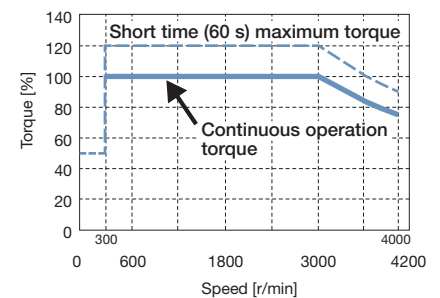

Motor outline dimensions

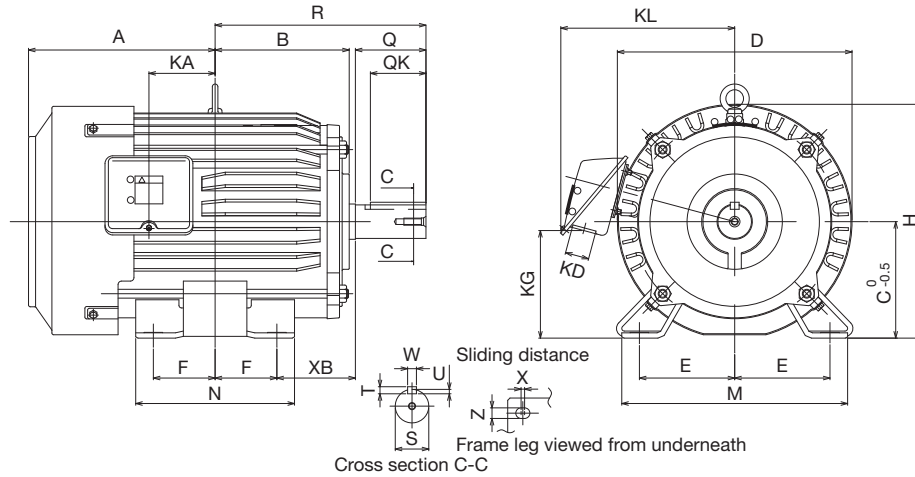

Model	Output (kW)	Frame No.	Outline dimension (mm)																							
			A	B	C	D	E	F	H	KA	KD	KG	KL	M	N	XB	Q	QK	R	S	T	U	W	X	Z	
200V class MM-EFS[]3	7	0.75	80M	122	93	80	162	62.5	50	166	39.5	27	63	145	160	125	50	40	32	140	ø19j6	6	3.5	6	15	9
	15	1.5	90L	143	111.5	90	184	70	62.5	191	53	27	76	158	175	150	56	50	40	168.5	ø24j6	7	4	8	15	9
	22	2.2		181	135	112	228	95	70	226	69	27	103	180	230	180	70	60	45	200	ø28j6	7	4	8	4	12
400V class MM-EFS[]34	37	3.7	112M	181	135	112	228	95	70	226	69	27	103	180	230	180	70	60	45	200	ø28j6	7	4	8	4	12
	55	5.5	132S	211.5	152	132	266	108	70	265	75	27	120	197	256	180	89	80	63	239	ø38k6	8	5	10	4	12
	75	7.5		160M	252	198	160	318	127	105	316	105	56	142	266	310	254	108	110	90	323	ø42k6	8	5	12	4
	11K	11	160M	252	198	160	318	127	105	316	105	56	142	266	310	254	108	110	90	323	ø42k6	8	5	12	4	14.5
15K	15	252		198	160	318	127	105	316	105	56	142	266	310	254	108	110	90	323	ø42k6	8	5	12	4	14.5	

Combination with the FR-F800 series inverter

Parameter settings for the MM-EFS 3000 r/min specification motors are added to the compatible inverters (FR-F800 series). *

1) Initializing the parameters required for the PM motor control (Pr.998)

PM parameter initialization facilitates setting parameters required for driving the MM-EFS 3000 r/min specification motor.

Pr.	Name	Initial value	Setting range	Description
998 E430	PM parameter initialization	0	14	Parameter setting for the MM-EFS 3000 r/min specification motor (rotations per minute)
			114	Parameter setting for the MM-EFS 3000 r/min specification motor (frequency)

2) Applied motor (Pr.71)

Setting of the applied motor selects the thermal characteristic appropriate for the motor.

Pr.71	Pr.450	Motor	Motor constant parameters	Operational characteristic of the electronic thermal O/L relay
240		IPM motor (MM-EFS 3000 r/min)	Setting in mH, %, or A	PM
243 (244)		IPM motor (MM-EFS 3000 r/min)	Setting according to the internal data	PM

* Available for the inverters manufactured in August 2015 or later.

Release schedule

October 2015

MITSUBISHI ELECTRIC CORPORATION

HEAD OFFICE: TOKYO BLDG., 2-7-3, MARUNOUCHI, CHIYODA-KU, TOKYO 100-8310, JAPAN