

**General-Purpose AC Servo
MELSERVO-J3**
Servo Motor < HF-JP Series (0.5 to 5kW) >

New low inertia and medium capacity (0.5kW to 5kW) servo motor has been added to MELSERVO-J3 Series motor lines.

The HF-JP series is a high-speed servo motor having a rated speed of 3000r/min and maximum speed of 6000r/min.

The HF-JP series is equipped with a high-resolution absolute encoder with 262144p/rev as standard specification.

As compared to the previous model HC-LP series, HF-JP has achieved a reduction in mass and volume (up to 68% in volume and 64% in mass).

The HF-JP series is well suited for “high-throughput positioning” and “high acceleration/deceleration”, due to the use of internal permanent magnets, which strengthen the rotor structure and allow for higher velocities (increased from 3000r/min to 6000r/min).

Thus, this servo motor particularly is suitable for food packaging and printing machines.

The HF-JP series will be compatible with global standards (EN, UL and c-UL standards).

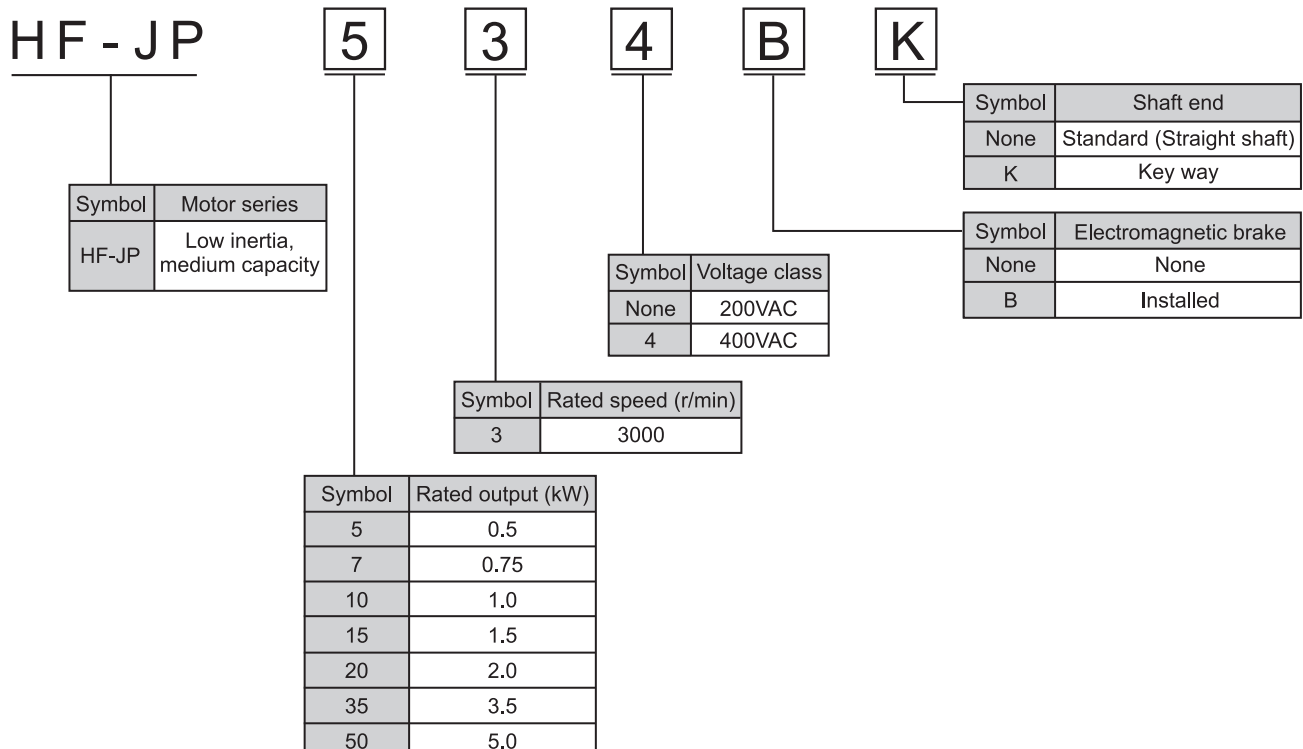
Model configurations

Servo motor specifications (200VAC class)

Servo motor series		HF-JP 3000r/min series (Low inertia, medium capacity)						
Servo motor model		HF-JP53(B)	HF-JP73(B)	HF-JP103(B)	HF-JP153(B)	HF-JP203(B)	HF-JP353(B)	HF-JP503(B)
Compatible servo amplifier model		MR-J3-60A/B(-RJ006)/T	MR-J3-70A/B(-RJ006)/T	MR-J3-100A/B(-RJ006)/T	MR-J3-200A/B(-RJ006)/T	MR-J3-200A/B(-RJ006)/T	MR-J3-350A/B(-RJ006)/T	MR-J3-500A/B(-RJ006)/T
Power supply capacity (Note 1) (kVA)		1.0	1.3	1.7	2.5	3.5	5.5	7.5
Continuous running duty (Note 7)	Rated output (kW)	0.5	0.75	1.0	1.5	2.0	3.3 <3.5>	5.0
	Rated torque (N·m [oz·in])	1.59 (225)	2.39 (338)	3.18 (450)	4.77 (675)	6.37 (902)	10.5 (1490) <11.1 (1570)>	15.9 (2250)
Maximum torque (N·m [oz·in])		4.77 (675)	7.16 (1010)	9.55 (1350)	14.3 (2020)	19.1 (2700)	32.0 (4530)	47.7 (6750)
Rated speed (r/min)		3000						
Maximum speed (r/min)		6000						
Permissible instantaneous speed (r/min)		6900						
Power rate at continuous rated torque (kW/s)		16.7	27.3	38.2	60.2	82.4	83.5	133
Rated current (Note 7) (A)		3.0	5.6	5.6	10.6	10.6	16.6 <17.6>	27
Maximum current (A)		9.0	17	17	32	32	51	81
Regenerative braking frequency (Note 2) (times/min)		67	98	76	271	206	73	68
Moment of inertia J (X10 ⁻⁴ kg·m ²) [J (oz·in ²)]	Standard	1.52 (8.31)	2.09 (11.4)	2.65 (14.5)	3.79 (20.7)	4.92 (26.9)	13.2 (72.2)	19.0 (104)
	With electromagnetic brake	2.02 (11.0)	2.59 (14.2)	3.15 (17.2)	4.29 (23.5)	5.42 (29.6)	15.4 (84.2)	21.2 (116)
Recommended load to motor inertia moment ratio		Maximum of 10 times the servo motor's inertia moment (Note 3)						
Speed/position detector		18-bit encoder (Resolution per encoder/servo motor rotation: 262144 p/rev)						
Attachments		Oil seal						
Insulation class		Class F						
Structure		Totally enclosed non-ventilated (IP code: IP67) (Note 4)						
Environment (Note 6)	Ambient temperature	0 to 40°C (32 to 104°F) (non freezing), storage: -15 to 70°C (5 to 158°F) (non freezing)						
	Ambient humidity	80% RH maximum (non condensing), storage: 90% RH maximum (non condensing)						
	Atmosphere	Indoors (no direct sunlight); no corrosive gas, inflammable gas, oil mist or dust						
	Elevation	1000m or less above sea level						
Mass (kg [lb])	Standard	3.0 (6.7)	3.7 (8.2)	4.5 (10)	5.9 (13)	7.5 (17)	13 (29)	18 (40)
	With electromagnetic brake	4.4 (9.7)	5.1 (12)	5.9 (13)	7.3 (16)	8.9 (20)	15 (33)	20 (44)
Maximally increased torque (Note 8)	Compatible servo amplifier model	MR-J3-100A/B(-RJ006)/T-U100	MR-J3-200A/B(-RJ006)/T-U101	MR-J3-200A/B(-RJ006)/T-U102	MR-J3-350A/B(-RJ006)/T-U103	MR-J3-350A/B(-RJ006)/T-U104	MR-J3-500A/B(-RJ006)/T-U105	MR-J3-700A/B(-RJ006)/T-U106
	Maximum torque (N·m [oz·in])	6.37 (902)	9.55 (1350)	12.7 (1800)	19.1 (2700)	25.5 (3610)	44.6 (6320)	63.7 (9020)
	Maximum current (A)	12	23	23	43	43	71	108

Notes: 1. The power supply capacity varies depending on the power supply's impedance.

2. The regenerative braking frequency shows the permissible frequency when the motor, without a load and the optional regeneration unit, decelerates from the rated speed to a stop.

3. Contact Mitsubishi if the load to motor inertia moment ratio exceeds the value in the table.

4. The shaft-through portion is excluded.

5. The vibration direction is shown in the diagram to the right.

The numeric value indicates the maximum value of the component (commonly the bracket in the opposite direction of the motor shaft).

Fretting of the bearing occurs easily when the motor stops, so maintain vibration to approximately one-half of the allowable value.

6. In the environment where the servo motor is exposed to oil mist, oil and/or water, a standard specification servo motor may not be usable.

Contact Mitsubishi for more details.

7. Value indicated in < > is when connected to servo amplifier MR-J3-500A/B(-RJ006)/T-U105.

8. Use servo amplifier MR-J3-□A/B(-RJ006)/T-U□ for maximally increased torque.



Servo motor torque characteristics (200VAC class)

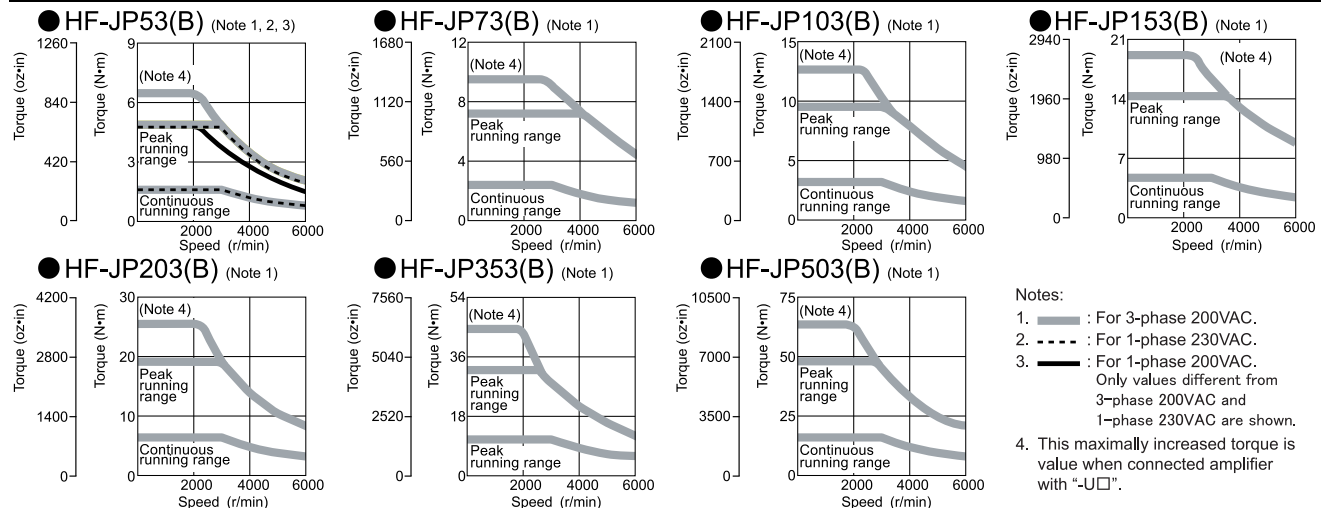

Servo motor specifications (400VAC class)

Servo motor series		HF-JP 3000r/min series (Low inertia, medium capacity)						
Servo motor model		HF-JP534(B)	HF-JP734(B)	HF-JP1034(B)	HF-JP1534(B)	HF-JP2034(B)	HF-JP3534(B)	HF-JP5034(B)
Compatible servo amplifier model		MR-J3-60A4/ B4(-RJ006)/ T4	MR-J3-100A4/ B4(-RJ006)/ T4	MR-J3-100A4/ B4(-RJ006)/ T4	MR-J3-200A4/ B4(-RJ006)/ T4	MR-J3-200A4/ B4(-RJ006)/ T4	MR-J3-350A4/ B4(-RJ006)/T4	MR-J3-500A4/ B4(-RJ006)/ T4
Power supply capacity (Note 1) (kVA)		1.0	1.3	1.7	2.5	3.5	5.5	7.5
Continuous running duty (Note 7)	Rated output (kW)	0.5	0.75	1.0	1.5	2.0	3.3 <3.5>	5.0
	Rated torque (N·m [oz·in])	1.59 (225)	2.39 (338)	3.18 (450)	4.77 (675)	6.37 (902)	10.5 (1490) <11.1 (1570)>	15.9 (2250)
Maximum torque (N·m [oz·in])		4.77 (675)	7.16 (1010)	9.55 (1350)	14.3 (2020)	19.1 (2700)	32.0 (4530)	47.7 (6750)
Rated speed (r/min)		3000						
Maximum speed (r/min)		6000						
Permissible instantaneous speed (r/min)		6900						
Power rate at continuous rated torque (kW/s)		16.7	27.3	38.2	60.2	82.4	83.5	133
Rated current (Note 7) (A)		1.5	2.8	2.8	5.4	5.4	8.3 <8.8>	14
Maximum current (A)		4.5	8.4	8.4	17	17	26	41
Regenerative braking frequency (Note 2) (times/min)		99	72	56	265	203	75	68
Moment of inertia J (X10 ⁻⁴ kg·m ²) [J (oz·in ²)]	Standard	1.52 (8.31)	2.09 (11.4)	2.65 (14.5)	3.79 (20.7)	4.92 (26.9)	13.2 (72.2)	19.0 (104)
	With electromagnetic brake	2.02 (11.0)	2.59 (14.2)	3.15 (17.2)	4.29 (23.5)	5.42 (29.6)	15.4 (84.2)	21.2 (116)
Recommended load to motor inertia moment ratio		Maximum of 10 times the servo motor's inertia moment (Note 3)						
Speed/position detector		18-bit encoder (Resolution per encoder/servo motor rotation: 262144 p/rev)						
Attachments		Oil seal						
Insulation class		Class F						
Structure		Totally enclosed non-ventilated (IP code: IP67) (Note 4)						
Environment (Note 6)	Ambient temperature	0 to 40°C (32 to 104°F) (non freezing), storage: -15 to 70°C (5 to 158°F) (non freezing)						
	Ambient humidity	80% RH maximum (non condensing), storage: 90% RH maximum (non condensing)						
	Atmosphere	Indoors (no direct sunlight); no corrosive gas, inflammable gas, oil mist or dust						
	Elevation	1000m or less above sea level						
	Vibration (Note 5)	X: 24.5m/s ² Y: 24.5m/s ²						
Mass (kg [lb])	Standard	3.0 (6.7)	3.7 (8.2)	4.5 (10)	5.9 (13)	7.5 (17)	13 (29)	18 (40)
	With electromagnetic brake	4.4 (9.7)	5.1 (12)	5.9 (13)	7.3 (16)	8.9 (20)	15 (33)	20 (44)
Maximally increased torque (Note 8)	Compatible servo amplifier model	MR-J3-100A4/ B4(-RJ006)/ T4-U110	MR-J3-200A4/ B4(-RJ006)/ T4-U111	MR-J3-200A4/ B4(-RJ006)/ T4-U112	MR-J3-350A4/ B4(-RJ006)/ T4-U113	MR-J3-350A4/ B4(-RJ006)/ T4-U114	MR-J3-500A4/ B4(-RJ006)/ T4-U115	MR-J3-700A4/ B4(-RJ006)/ T4-U116
	Maximum torque (N·m [oz·in])	6.37 (902)	9.55 (1350)	12.7 (1800)	19.1 (2700)	25.5 (3610)	44.6 (6320)	63.7 (9020)
	Maximum current (A)	6.0	12	12	22	22	36	54

- Notes:
- The power supply capacity varies depending on the power supply's impedance.
 - The regenerative braking frequency shows the permissible frequency when the motor, without a load and the optional regeneration unit, decelerates from the rated speed to a stop.
 - Contact Mitsubishi if the load to motor inertia moment ratio exceeds the value in the table.
 - The shaft-through portion is excluded.
 - The vibration direction is shown in the diagram to the right.
The numeric value indicates the maximum value of the component (commonly the bracket in the opposite direction of the motor shaft).
Fretting of the bearing occurs easily when the motor stops, so maintain vibration to approximately one-half of the allowable value.
 - In the environment where the servo motor is exposed to oil mist, oil and/or water, a standard specification servo motor may not be usable. Contact Mitsubishi for more details.
 - Value indicated in < > is when connected to servo amplifier MR-J3-500A4/B4(-RJ006)/T4-U115.
 - Use servo amplifier MR-J3-□A4/B4(-RJ006)/T4-U□ for maximally increased torque.



Servo motor torque characteristics (400VAC class)

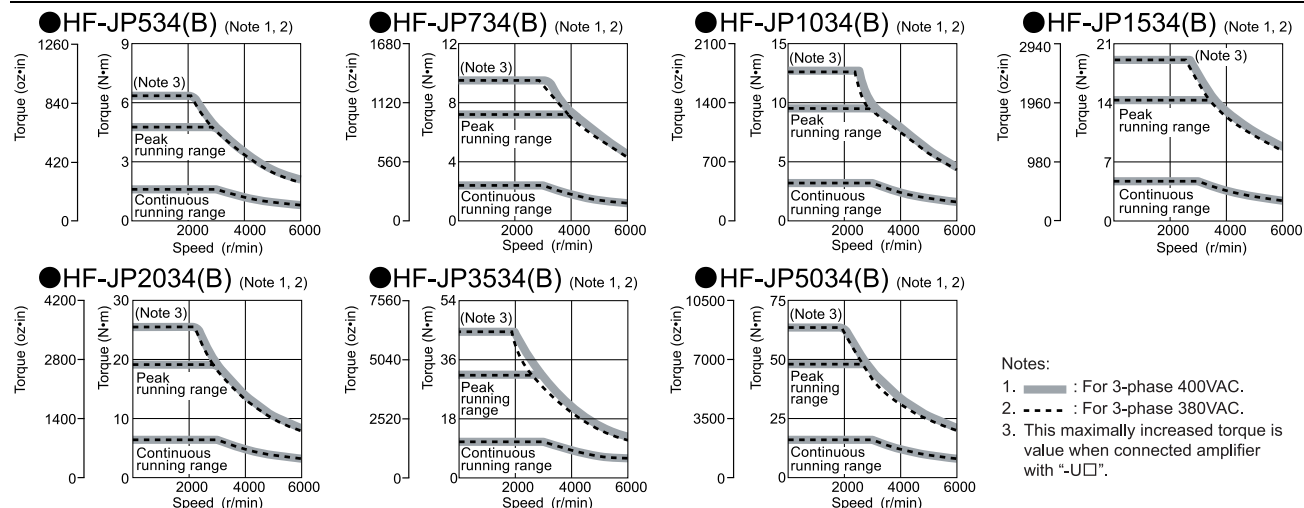

Servo motor dimensions (400VAC class)

(Unit: mm)

HF-JP534(B), HF-JP734(B), HF-JP1034(B), HF-JP1534(B), HF-JP2034(B)

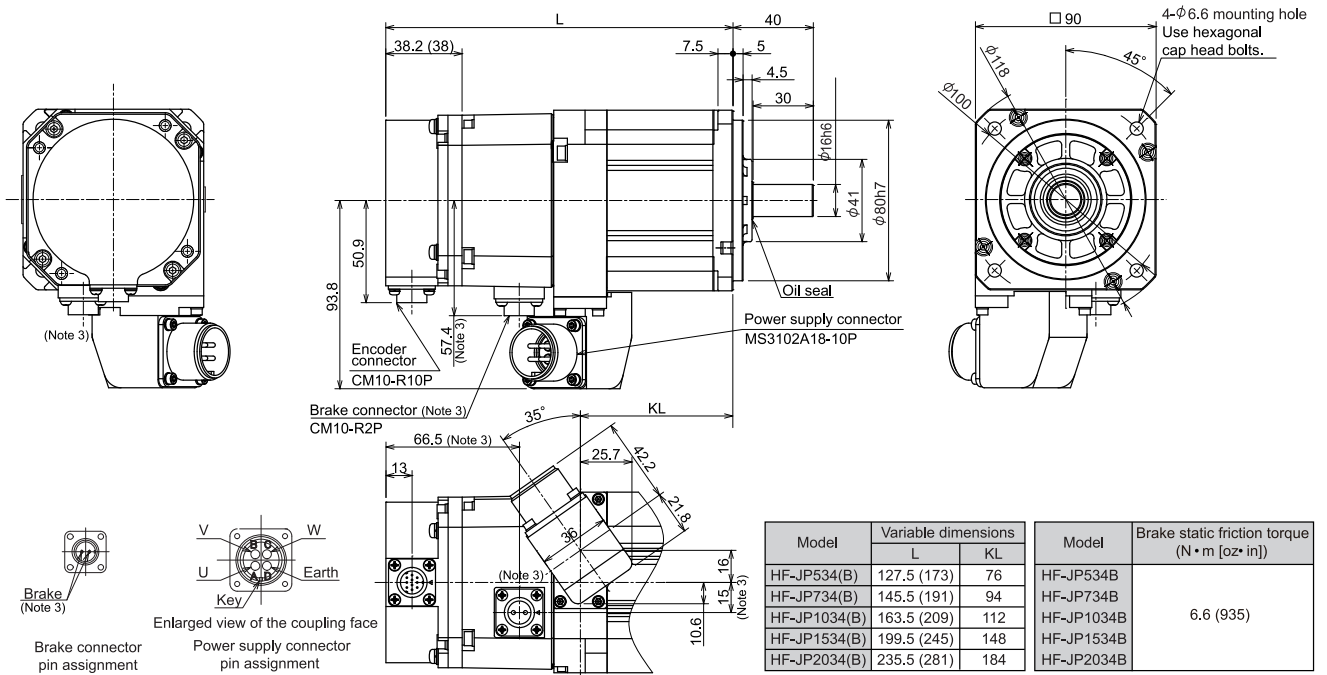

HF-JP3534(B), HF-JP5034(B)

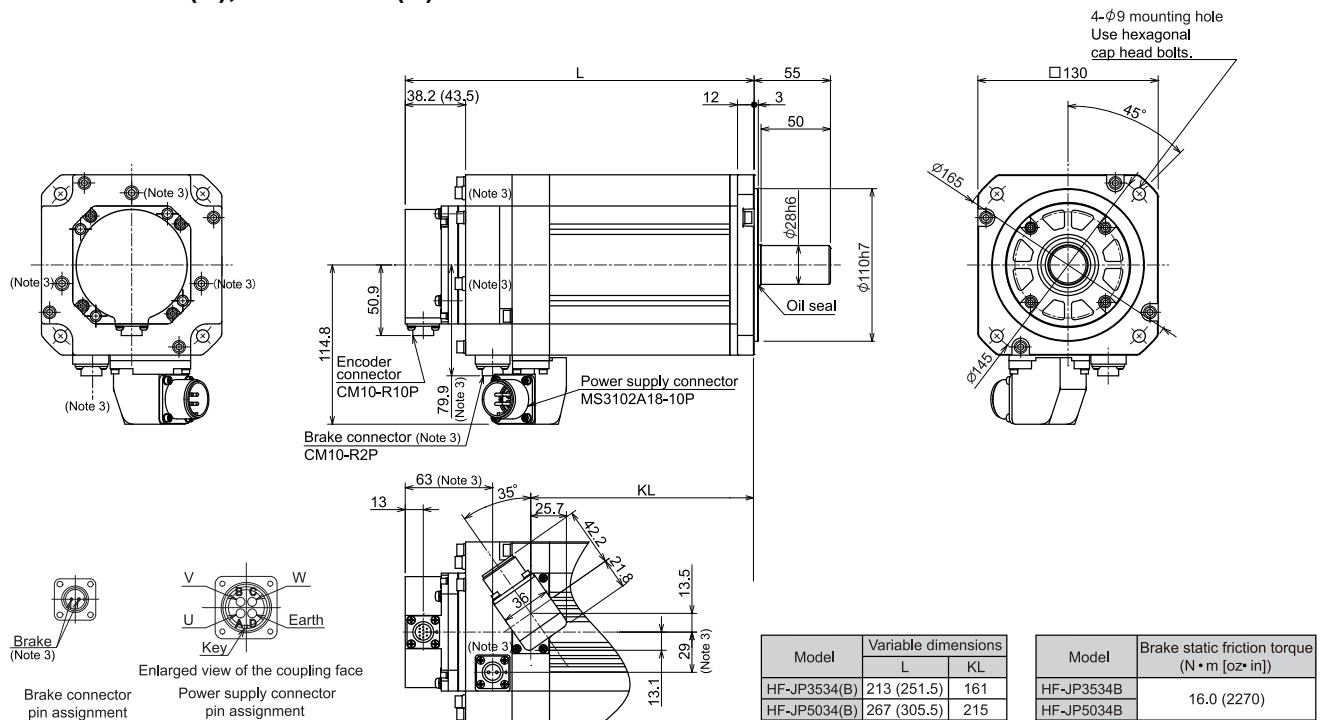

- Notes: 1. Use a friction coupling to fasten a load.
 2. Dimensions inside () are for the models with an electromagnetic brake.
 3. Only for the models with an electromagnetic brake. The electromagnetic brake terminals do not have polarity.
 4. For dimensions where there is no tolerance listed, use general tolerance.

Options

Cables and connectors

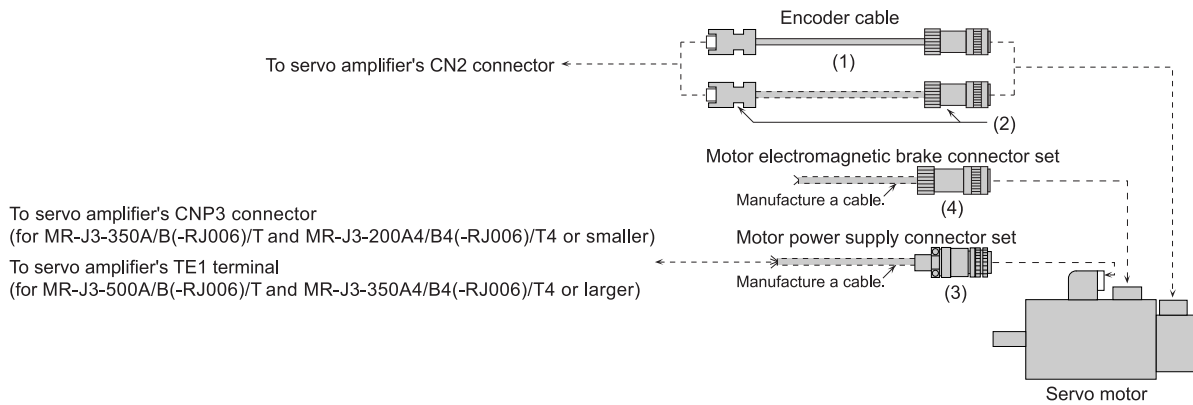

Item		Model	IP code (Note 3)	Description
For Encoder	(1) Encoder cable	MR-J3ENSCBL□M-H (Note 1, 2) □=cable length: 2, 5, 10, 20, 30, 40, 50m	IP67	Amplifier connector 36210-0100PL (receptacle, 3M) 36310-3200-008 (shell kit, 3M) or 54599-1019 (connector set, Molex)
		MR-J3ENSCBL□M-L (Note 1, 2) □=cable length: 2, 5, 10, 20, 30m	IP67	Encoder connector (DDK) <For 10m or shorter cable> CM10-SP10S-M(D6) (straight plug) CM10-#22SC(C1)(D8)-100 (socket contact)
	(2) Encoder connector set	MR-J3SCNS (Note 2) (Straight type)	IP67	Amplifier connector 36210-0100PL (receptacle, 3M) 36310-3200-008 (shell kit, 3M) or 54599-1019 (connector set, Molex)
		MR-J3SCNSA (Note 2) (Angled type)	IP67	Encoder connector (DDK) CM10-AP10S-M(D6) (angled plug) CM10-#22SC(S1)(D8)-100 (socket contact) <Applicable cable example> Wire size: 0.5mm ² (AWG20) or smaller Completed cable outer diameter: φ6.0 to 9.0mm
For motor power supply	(3) Power supply connector set for HF-JP53, 73, 103, 153, 203, 534, 734, 1034, 1534, 2034, 3534, 5034	MR-PWCNS4 (Straight type)	IP67	Motor power supply connector (DDK) CE05-6A18-10SD-D-BSS (plug) (straight) CE3057-10A-1-D (cable clamp) <Applicable cable example> Wire size: 2mm ² (AWG14) to 3.5mm ² (AWG12) Completed cable outer diameter: φ10.5 to 14.1mm
	Power supply connector set for HF-JP353, 503	MR-PWCNS5 (Straight type)	IP67	Motor power supply connector (DDK) CE05-6A22-22SD-D-BSS (plug) (straight) CE3057-12A-1-D (cable clamp) <Applicable cable example> Wire size: 5.5mm ² (AWG10) to 8mm ² (AWG8) Completed cable outer diameter: φ12.5 to 16mm
For motor electromagnetic brake	(4) Brake connector set	MR-BKCNS1 (Note 2) (Straight type)	IP67	Motor brake connector (DDK) (soldered type) CM10-SP2S-L(D6) (straight plug) CM10-#22SC(S2)(D8)-100 (socket contact) <Applicable cable example> Wire size: 1.25mm ² (AWG16) or smaller Completed cable outer diameter: φ9.0 to 11.6mm
		MR-BKCNS1A (Note 2) (Angled type)	IP67	Motor brake connector (DDK) (soldered type) CM10-AP2S-L(D6) (angled type) CM10-#22SC(S2)(D8)-100 (socket contact) <Applicable cable example> Wire size: 1.25mm ² (AWG16) or smaller Completed cable outer diameter: φ9.0 to 11.6mm

Notes: 1. -H and -L indicate bending life. -H indicates long bending life, and -L indicates standard bending life.

2. Select from below if there is a potential risk that a high vibration may be applied to connectors.

- Encoder cable: MR-J3ENSCBL□M-H-S06 (long bending life) or MR-J3ENSCBL□M-L-S06 (standard bending life)
- Encoder connector set: MR-J3SCNS-S06 (straight type) or MR-J3SCNSA-S06 (angled type)
- Brake connector set: MR-BKCNS1-S06 (straight type) or MR-BKCNS1A-S06 (angled type)
- Connector cover: MR-J3ENS-CVR (straight type) or MR-J3ENSA-CVR (angled type)

Be sure to use connector cover when using our standard cable or connector set in the table above.

Contact Mitsubishi for more details.



3. The IP code indicated is for the connector's protection against ingress of dust and water when coupled to a servo amplifier/servo motor.

If the IP code of the servo amplifier/servo motor differs from that of these connectors, overall IP code depends on the lowest of all.

■ Ordering information for customers

To order the following products, contact the relevant manufacturers directly.

● Encoder connectors

Item	Connector			Contact	IP code (Note 3)	Description	Applicable cable example	
	Type	Plug	Socket contact				Wire size	Completed cable outer diameter
Motor encoder connector	Straight	CM10-SP10S-M(D6) (Note 2)	CM10-#22SC(C1)(D8)-100	Press bonding type	IP67	 Manufacturer: DDK Ltd.	0.3mm ² (AWG22) to 0.5mm ² (AWG20) Crimping tool (357J-50446T) is required.	ø6.0 to 9.0mm
			CM10-#22SC(C2)(D8)-100					
			CM10-#22SC(S1)(D8)-100	Soldered type				
	Angled	CM10-AP10S-M(D6) (Note 2)	CM10-#22SC(C1)(D8)-100	Press bonding type	IP67	 Manufacturer: DDK Ltd.	0.3mm ² (AWG22) to 0.5mm ² (AWG20) Crimping tool (357J-50446T) is required.	
			CM10-#22SC(C2)(D8)-100					
			CM10-#22SC(S1)(D8)-100	Soldered type				
Amplifier CN2 connector (Note 1)	-	54599-1019 (connector set)		-	-	 Manufacturer: Molex	-	-

Notes: 1. 3M also manufactures a connector compatible with the amplifier's CN2 connector.

Model: 36210-0100PL (receptacle), 36310-3200-008 (shell kit).

2. Select from below if there is a potential risk that a high vibration may be applied to connectors.

CM10-SP10S-VP-M (straight type) or CM10-AP10S-VP-M (angled type)

3. The IP code indicated is for the connector's protection against ingress of dust and water when coupled to a servo amplifier/servo motor. If the IP code of the servo amplifier/servo motor differs from that of these connectors, overall IP code depends on the lowest of all.

● Motor power supply connectors

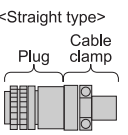
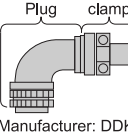
Item	Plug (with backshell)		Cable clamp	IP code (Note 2)	Description	Applicable cable example	
	Type	Model	Model			Wire size	Completed cable outer diameter
Motor power supply connector for HF-JP53, 73, 103, 153, 203, 534, 734, 1034, 1534, 2034, 3534, 5034	Straight	CE05-6A18-10SD-D-BSS	CE3057-10A-2-D	IP67 EN standards	 Manufacturer: DDK Ltd.	2mm ² (AWG14) to 3.5mm ² (AWG12)	ø8.5 to 11mm
			CE3057-10A-1-D				ø10.5 to 14.1mm
	Angled	CE05-8A18-10SD-D-BAS	CE3057-10A-2-D	ø8.5 to 11mm			
			CE3057-10A-1-D	ø10.5 to 14.1mm			
Motor power supply connector for HF-JP353, 503	Straight	CE05-6A22-22SD-D-BSS	CE3057-12A-2-D	IP67 EN standards	 Manufacturer: DDK Ltd.	3.5mm ² (AWG12) to 8mm ² (AWG8)	ø9.5 to 13mm
			CE3057-12A-1-D				ø12.5 to 16mm
	Angled	CE05-8A22-22SD-D-BAS	CE3057-12A-2-D	ø9.5 to 13mm			
			CE3057-12A-1-D	ø12.5 to 16mm			
Straight	D/MS3106B22-22S	D/MS3057-12A	General environment (Note 1)	General environment (Note 1)	ø15.9mm or smaller (Inner diameter of bushing)		
						Angled	D/MS3108B22-22S

Notes: 1. Not compliant with EN standards.

2. The IP code indicated is for the connector's protection against ingress of dust and water when coupled to a servo amplifier/servo motor.

If the IP code of the servo amplifier/servo motor differs from that of these connectors, overall IP code depends on the lowest of all.

■ Ordering information for customers

● Motor brake connectors

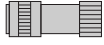
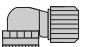
Item	Connector			Contact	IP code (Note 2)	Description	Applicable cable example		
	Type	Plug (Note 1)	Socket contact				Wire size	Completed cable outer diameter	
Motor brake connector	Straight	CM10-SP2S-S(D6)	CM10-#22SC(S2)(D8)-100	Soldered type	IP67	 Manufacturer: DDK Ltd.	1.25mm ² (AWG16) or smaller	ø4.0 to 6.0mm	
		CM10-SP2S-M(D6)						ø6.0 to 9.0mm	
		CM10-SP2S-L(D6)						ø9.0 to 11.6mm	
		CM10-SP2S-S(D6)		Press bonding type				0.5mm ² (AWG20) to 1.25mm ² (AWG16) Crimping tool (357J-50448T) is required.	ø4.0 to 6.0mm
		CM10-SP2S-M(D6)							ø6.0 to 9.0mm
		CM10-SP2S-L(D6)							ø9.0 to 11.6mm
	Angled	CM10-AP2S-S(D6)	CM10-#22SC(S2)(D8)-100	Soldered type	IP67	 Manufacturer: DDK Ltd.	1.25mm ² (AWG16) or smaller		ø4.0 to 6.0mm
		CM10-AP2S-M(D6)							ø6.0 to 9.0mm
		CM10-AP2S-L(D6)							ø9.0 to 11.6mm
		CM10-AP2S-S(D6)		Press bonding type				0.5mm ² (AWG20) to 1.25mm ² (AWG16) Crimping tool (357J-50448T) is required.	ø4.0 to 6.0mm
		CM10-AP2S-M(D6)							ø6.0 to 9.0mm
		CM10-AP2S-L(D6)							ø9.0 to 11.6mm

Notes: 1. Select from below if there is a potential risk that a high vibration may be applied to connectors.

CM10-SP2S-VP-S/M/L (straight type) or CM10-AP2S-VP-S/M/L (angled type)

2. The IP code indicated is for the connector's protection against ingress of dust and water when coupled to a servo amplifier/servo motor.
If the IP code of the servo amplifier/servo motor differs from that of these connectors, overall IP code depends on the lowest of all.