

## Sales and Service

### Terminal Block Change for the Large Capacity Servo Motor

Thank you for your continued patronage of the Mitsubishi general-purpose AC servo and FA products. Since FUJI ELECTRIC INDUSTRY CO., LTD. discontinues the production of TU-15B and TU-20B terminal blocks, we will change the terminal blocks for large capacity AC servo motors as follows. We ask for your understanding in this matter.

#### 1. Target Models

This change applies to the following large capacity AC servo motors.

- (1) HA-LP\_/HA-LFS\_
- (2) HG-JR\_(22 to 55 kW 1500 r/min series)
- (3) HG-JR\_(15 to 37 kW 1000 r/min series)

#### 2. Details of Change

Since FUJI ELECTRIC INDUSTRY CO., LTD. discontinues the production of TU-15B and TU-20B terminal blocks, we will change the terminal blocks as follows. This change does not affect the servo motor functions and performance.

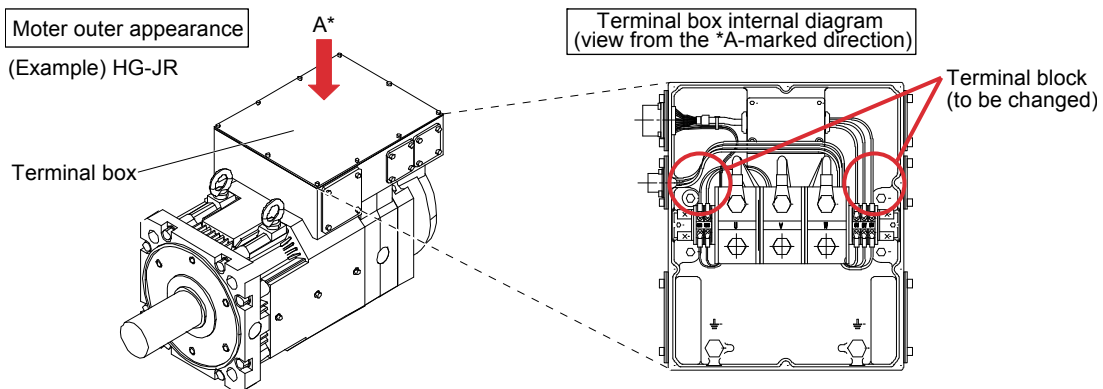

<b>Date of issue</b>	September 2014	<b>Title</b>	Terminal Block Change for the Large Capacity Servo Motor	Mitsubishi Electric Corp., Nagoya Works 5-1-14 Yada-minami, Higashi-ku, Nagoya 461-8670 Tel.: +81 (52) 721-2111 Main line
----------------------	----------------	--------------	--	---

[HA-LP\_/HA-LFS\_]

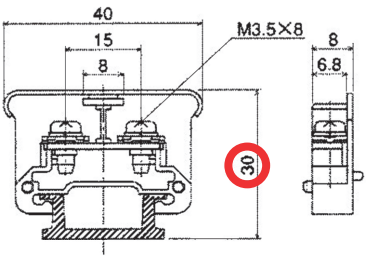
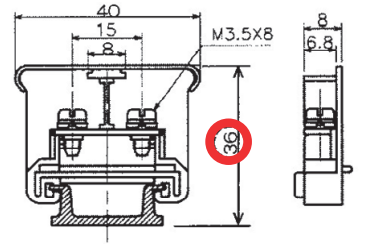
	Terminal block model	Terminal block outer appearance
Before change	TU-15B	
After change	TU-15C	

[HG-JR\_(22 to 55 kW 1500 r/min series), HG-JR\_(15 to 37 kW 1000 r/min series)]

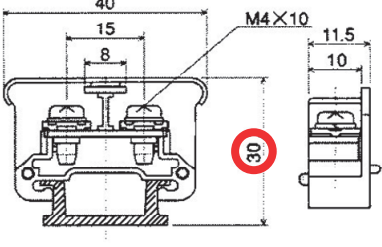
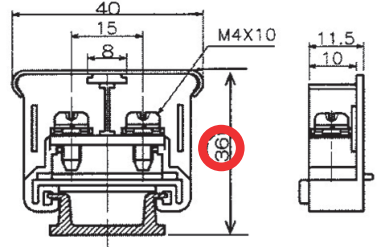
	Terminal block model	Terminal block outer appearance
Before change	TU-20B	
After change	TU-30B	

**3. Schedule**

This change will be made sequentially from October 2014 production.

There may be cases when both new and old products exist in the distribution stage. We ask for your understanding in this matter.