



TECHNICAL BULLETIN

[1 / 53]

[Issue No.] GOT-A-0064-AD

[Title] List of Valid Devices Applicable for GOT2000 Series (for Japanese Market)

[Date of Issue] September 2013 (Ver. AD: June 2023)

[Relevant Models] GOT2000 Series

Thank you for your continued support of Mitsubishi Electric Graphic Operation Terminal (GOT).
This bulletin provides information on peripheral devices and controllers validated to operate with the GOT2000 series.

For how to use each product, refer to the respective product's manual.

Regarding the production status of each product, confirm with the manufacturer.

Recommended Product

Products that are compliant with Mitsubishi Electric standards.
Use Recommended Products according to their specifications.

Compatible Product

Products that are connectable to Mitsubishi Electric products.
(Note that compatibility is not verified by Mitsubishi Electric.)
Use Compatible Products according to their specifications.

Some Compatible Products may not be connected because their specifications have changed depending on the date of manufacture.

Verify Compatible Products, and determine whether or not to use the products.

Discontinued Product

Recommended Products or Compatible Products that have been mentioned in the bulletin before, but may be difficult to procure because they have been discontinued.

Incompatible Product

Products that are not connectable to Mitsubishi Electric products.
Use Compatible Products.

Contents

1. Memory Card (CF card and SD card).....	3
2. USB Memory.....	3
3. Barcode Reader.....	4
3.1 Compatible Products.....	4
3.1.1 RS-232 connection.....	4
3.1.2 RS-422/485 connection.....	4
3.1.3 USB connection.....	5
3.2 System equipment of barcode readers.....	6
3.2.1 System equipment (1).....	6
3.2.2 System equipment (2).....	8
3.2.3 System equipment (3).....	9
3.2.4 System equipment (4).....	9
3.2.5 System equipment (5).....	10
3.2.6 System equipment (6).....	10
3.2.7 System equipment (7).....	11
3.2.8 System equipment (8).....	12
3.2.9 System equipment (9).....	13
3.2.10 System equipment (10).....	14
3.3 Compatible barcode types.....	15
3.4 How to read data by a barcode reader.....	16
3.5 When using the GT21 model.....	16
4. 2D Code Reader.....	17

MITSUBISHI ELECTRIC CORPORATION

HEAD OFFICE: TOKYO BLDG., 2-7-3, MARUNOUCHI, CHIYODA-KU, TOKYO 100-8310, JAPAN
NAGOYA WORKS: 1-14, YADA-MINAMI 5-CHOME, HIGASHI-KU, NAGOYA 461-8670, JAPAN

4.1	Compatible Products	17
4.1.1	RS-232 connection	17
4.1.2	RS-422/485 connection	18
4.1.3	USB connection	18
4.2	System equipment of 2D code reader	21
4.2.1	System equipment (1)	21
4.2.2	System equipment (2)	23
4.2.3	System equipment (3)	24
4.2.4	System equipment (4)	25
4.2.5	System equipment (5)	26
4.2.6	System equipment (6)	26
4.2.7	System equipment (7)	26
4.2.8	System equipment (8)	28
4.2.9	System equipment (9)	28
4.2.10	System equipment (10)	29
4.2.11	System equipment (11)	29
4.2.12	System equipment (12)	29
4.3	Compatible 2D code type	30
4.4	How to read data by a 2D code reader	30
4.5	When using the GT21 model	30
5.	Hubs for Ethernet Connection and Gateway Function	31
6.	Video Camera	31
7.	Display	31
8.	Speaker	32
8.1	When using the sound output unit mounted on the GOT	32
8.2	When using the sound output interface of the GT25 wide model	32
9.	RFID Controller	33
9.1	Compatible Products	33
9.1.1	RS-232 connection	33
9.1.2	RS-422/485 connection	33
9.2	System equipment of RFID controllers	34
9.2.1	When using the RS-232 connection	34
9.2.2	When using the RS-422/485 connection	38
9.3	How to read data by an RFID controller	41
9.4	RFID Controllers Available for the External Authentication	42
10.	USB Mouse Function	42
11.	USB Keyboard Function	42
11.1	USB Keyboard	42
11.2	USB Barcode Reader	42
11.3	USB RFID Controller	42
11.4	Other device	43
12.	USB Hub	43
13.	USB Cable	43
14.	Wireless LAN Access Point	43
15.	Printer	44
15.1	PictBridge compatible printer	44
15.2	Serial printer	45
15.3	Ethernet printer	47
15.3.1	ESC/P-R	47
15.3.2	PCL5	48
16.	Media converter	51
	REVISIONS	52
	Intellectual Property Rights	53

1. Memory Card (CF card and SD card)

○: Supported, ×: Not supported

Supported memory card	GOT	
	GOT2000	GT27-MMR-Z
CF card (MITSUBISHI GT05-MEM-□C)	×	○
SD card (MITSUBISHI L1MEM-□GBSD, NZ1MEM-□GBSD)	○	×

For the applicable non-Mitsubishi Electric memory cards (CF cards and SD cards), refer to the following Technical Bulletins.

- Non-Mitsubishi Electric CF card: No. GOT-A-0025 "Operation Check Results of Third Party CF Cards on GOT1000 Series Units"
- Non-Mitsubishi Electric SD card: No. GOT-A-0065 "Operation Check Results of Non-Mitsubishi SD Cards on GOT2000 Series Units"

2. USB Memory

Item	Specification
USB memory	USB hub compliant with USB2.0 (including forward-compatible with USB3.0 and others) *1*2*3

- *1 A USB memory with a capacity up to 32 GB can be used.
- *2 A USB memory with a particular function and others may not be available depending on the USB memory type.
Particular function examples:
 - A composite device (including a hub function and a card reader function)
 - A USB memory with an authentication function, an encryption function, or a security function including an anti-virus function and others
 - A USB memory whose functions are added by dedicated driver software.
- *3 USB memory that has been formatted in FAT or FAT32 is available.
 - FAT: Up to 2GB
 - FAT32: Up to 32GB

3. Barcode Reader

3.1 Compatible Products

3.1.1 RS-232 connection

○: Supported, ×: Not supported, -: Not validated

Manufacturer	Model	Operation validation		Refer to
		GOT2000	GT SoftGOT2000	
AIMEX Corporation	BR-530RS-B1	○	○	3.2.1
	BW-880RS-B1 *1	○	○	
	Z-3220	○	○	3.2.4
IDEC AUTO-ID SOLUTIONS Corporation	DS2200-1100	○	○	3.2.1
	DS2100-1114 *3	○	○	
	GRYPHON D100 *3	○	○	
	GRYPHON D130 *3	○	○	
	DS2100N-□□□□	○	○	3.2.6
	DS2400N-□□□□	○	○	
	DS4800-1□00	○	○	
	QD2130-□□ *3	○	○	3.2.4
	QD2131-□□	○	○	
	QD4130-□□	○	○	
	GBT4130-BK-BT	○	○	
NEC Platforms, Ltd.	MG1100i-1D	○	○	3.2.4
	PD7130-YB-PTR	○	○	3.2.4
	BCH5542-STA	○	○	3.2.1
OMRON Corporation	BCR5342H-STZ	○	○	3.2.1
	V520-RH21-6	○	○	3.2.2
OPTOELECTRONICS CO.,LTD.	OPT-5125-RS232C(H)	○	○	3.2.1
	OPL-6735-RS232C(X04)	○	○	
	NFT-7175-RS-1	○	○	3.2.4
	OPL-6845R-RS232	○	○	
KEYENCE CORPORATION	BL-210R	○	○	3.2.1
	BL-210RK *2	○	×	
	BL-601	○	○	
	BL-N70R	○	○	
	SR-510	○	○	
	HR-50R	○	○	
DENSO WAVE Incorporated	GT10B-SB	○	○	3.2.4
MARS TOHKEN SOLUTION CO.,LTD	TLMS-3500RV	○	○	3.2.7
	THLS-6712	○	○	
	THLS-6800	○	○	
Nippon Systems Development Co.,Ltd.	AC-812-000-D1	○	○	3.2.1
	PDC-812-400-00+PDC-812-300-D1	○	○	
Motorola Solutions, Inc.	LS2208	○	○	3.2.3
	LI4278	○	○	3.2.2
Honeywell International Inc.	3800G-04E	○	○	3.2.1

*1 When the barcode reader is connected to the GOT, turn it on in either of the following conditions.

- More than two seconds have elapsed since the GOT is turned on.
- The logo [GOT2000] is displayed on the screen after the GOT is turned on.

*2 GT27 model and GT25 model are available only. (Configure the settings in the utility of the GOT to supply 5VDC.)

*3 This is a discontinued product.

3.1.2 RS-422/485 connection

○: Supported, ×: Not supported, -: Not validated

Manufacturer	Model	Operation validation		Refer to
		GOT2000	GT SoftGOT2000	
IDEC AUTO-ID SOLUTIONS Corporation	DS2100N-1214	○	×	3.2.8

3.1.3 USB connection

You can use the USB barcode readers that satisfy the following conditions.

- A USB2.0-compliant USB keyboard interface is provided.
- An OADG-compliant Japanese 106 keyboard, English 101 keyboard, or equivalent is settable.
- "Enter" is settable as the terminator.

○: Supported, ×: Not supported, -: Not validated

Manufacturer	Model	Operation validation		Refer to
		GOT2000	GT SoftGOT2000	
IDEC AUTO-ID SOLUTIONS Corporation	QD2131-□□	○	×	3.2.9
	GD4130-□□	○	×	
Aug, Inc.	AUG-500SDW-USB(HID)	○	○	3.2.9
OPTOELECTRONICS CO.,LTD.	OPL-6845V	○	○	3.2.9
	L-46R-V-WHT-USB	○	○	
KEYENCE CORPORATION	HR-100	○	○	3.2.9
DENSO WAVE INCORPORATED	HC56TU	○	○	3.2.9
MARS TOHKEN SOLUTION CO.LTD.	THLS-7800U	○	○	3.2.9
NICHIEI INTEC CO., LTD.	FFTA21BU	○	○	3.2.9
	FFTA10AUSB	○	○	
Unitech Electronics Co., LTD.	MS840BT	○	×	3.2.10
Zebra Technologies, Inc.	LS2208	○	×	3.2.9
SICK Inc.	IDM240-100H *1	○	×	3.2.9
Honeywell International Inc.	Xenon 1900GSR-1	○	○	3.2.9

*1 GT27 / GT25-W / GT2505-V are supported with CoreOS version V or later and GT 23 with CoreOS version N or later. Not supported by GT21-W.

When you use the above models, the USB keyboard function is available. (The input value is processed as the ASCII code.)

For the usage instructions, refer to the following.

- GT Designer3 (GOT2000) Screen Design Manual (SH-081220ENG)

3.2 System equipment of barcode readers

The following shows the equipment to configure with different types of barcode readers.

3.2.1 System equipment (1)

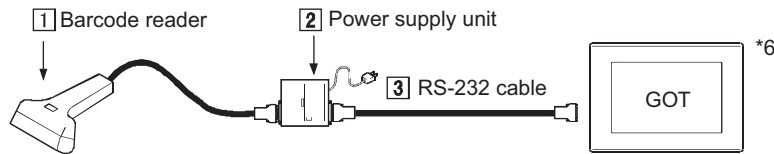

Manufacturer	1 Barcode reader	2 Power supply unit	3 RS-232 cable *8
AIMEX Corporation	BR-530RS-B1	Included with a barcode reader (An adapter (BB-60) must be purchased separately.)	Included with a barcode reader
	BW-880RS-B1	Included with a barcode reader	Included with a barcode reader
IDEC AUTO-ID SOLUTIONS Corporation	DS2200-1100	DSPW-2102	GT01-C30R2-25P *1
	DS2100-1114 *7	DSPW-2102	GT01-C30R2-25P *1
	GRYPHON D100	PG5 MAIN POWER BLOCK	Included with a barcode reader
	GRYPHON D130	11-0387 or UL310-0515 *7	Sold separately: CAB-327/CAB-350/CAB-362
NEC Platforms, Ltd.	BCH5542-STA	BCV5070 or CA1071	GT01-C30R2-9S *1
	BCR5342H-STZ	BCV5070 or BCA1071	GT01-C30R2-9S *1
OPTOELECTRONICS CO.,LTD.	OPT-5125-RS232C(H)	Not necessary	Included with a barcode reader *2
	OPL-6735-RS232C(X04)	DC-5300T	Included with a barcode reader
	NFT-7175-RS-1	GT27, GT25: Not necessary GT21: DC-5300T	GT27,GT25: Included with a barcode reader GT21: Power supply jack with cable is necessary
KEYENCE CORPORATION	BL-210R	Included with a barcode reader	Included with a barcode reader
	BL-210RK	Not necessary	Produced by the user Refer to 1) below. (5VDC is required.)
	BL-601	BL-U1	Produced by the user Refer to 2) below. *3
		BL-U2	Produced by the user Refer to 3) below. *4
	BL-N70R	R3W005-025J	Included with a barcode reader
MARS TOHKEN SOLUTION CO.,LTD	SR-510	BL-U2	GT01-C30R2-9S
	TLMS-3500RV	Not necessary *5	GT01-C30R2-25P *1
	THLS-6712	AD-6712	Included with a barcode reader
	THLS-6800	An adapter must be purchased separately.	Included with a barcode reader
Motorola Solutions, Inc.	LI4278	Cradle: STB4278-C0001WR Power supply: 50-14000-010	CBA-R01-S07PAR

*1 This is a Mitsubishi Electric product. Please contact your local Mitsubishi Electric or representative for purchasing the cable.
 *2 When purchasing OPT-5125-RS232C(H), select one with the same connector shape as OPL-6735-RS232C(X04).
 *3 The OP-22149(1.5m) and the OP-25057 (conversion connector) manufactured by KEYENCE CORPORATION are available.
 *4 The OP-27937(2m) manufactured by KEYENCE CORPORATION is available.
 *5 It is necessary to supply 24 V DC to the barcode reader separately. For details of the power supply specifications, refer to the manual of the barcode reader to be used.
 *6 When using a barcode reader, follow one of the procedures below to turn on it.
 · Turn on the GOT, wait 2 seconds or more, and turn on the barcode reader.
 · Turn on the GOT, wait for the startup logo to appear, and turn on the barcode reader.
 If you use any procedure other than the above and the barcode reader becomes inoperable, restart the barcode reader.
 *7 This is a discontinued product.
 *8 Available to GT2104-PMBDS, GT2104-PMBDS2, GT2103-PMBDS, and GT2103-PMBDS2 when the RS-232 connector conversion cable (GT10-C02H-6PT9P) is used together.

[Issue No.] GOT-A-0064-AD

1) Cable connection diagram for a barcode reader manufactured by KEYENCE CORPORATION (BL-210RK)
 The following shows connection cables that must be produced by the user.
 Maximum cable length: confirm with the barcode reader manufacturer.

Barcode reader		Cable connection and signal direction	GOT	
Signal name	Pin No.		Pin No.	Signal name
SG	1		1	CD
RD(RXD)	2		2	RD(RXD)
SD(TXD)	3		3	SD(TXD)
ER(DTR)	4		4	ER(DTR)
SG	5		5	SG
DR(DSR)	6		6	DR(DSR)
RS(RTS)	7		7	RS(RTS)
CS(CTS)	8		8	CS(CTS)
5V	9		9	5V

2) RS-232 cable connection diagram for a barcode reader manufactured by KEYENCE CORPORATION (BL-601, BL-U1)

The following shows connection cables that must be produced by the user.
 Maximum cable length: confirm with the barcode reader manufacturer.

Barcode reader		Cable connection and signal direction	GOT	
Signal name	Pin No.		Pin No.	Signal name
FG	1			Connector case
SD	2		2	RD(RXD)
RD	3		3	SD(TXD)
RS	4		4	ER(DTR)
CS	5		5	SG
DR	6		6	DR(DSR)
SG	7		7	RS(RTS)
	8		8	CS(CTS)
ER	20		9	—

3) Cable connection diagram for a barcode reader manufactured by KEYENCE CORPORATION (BL-601, BL-U2)
 The following shows connection cables that must be produced by the user.
 Maximum cable length: confirm with the barcode reader manufacturer.

Barcode reader		Cable connection and signal direction	GOT	
Signal name	Pin No.		Pin No.	Signal name
Connector case				Connector case
RD	2		2	RD(RXD)
SD	3		3	SD(TXD)
ER	4		4	ER(DTR)
SG	5		5	SG
DR	6		6	DR(DSR)
RS	7		7	RS(RTS)
CS	8		8	CS(CTS)
—	9		9	—

3.2.2 System equipment (2)

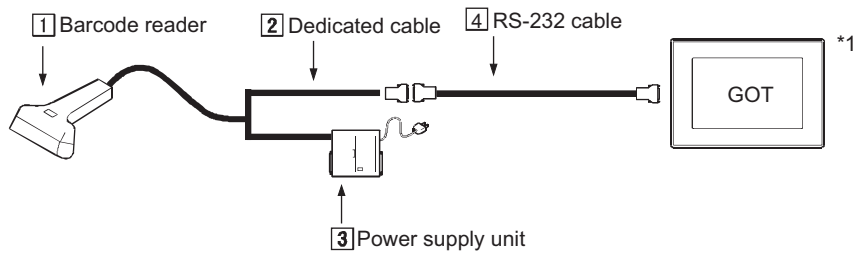

Manufacturer	1 Barcode reader	2 Dedicated cable	3 Power supply unit	4 RS-232 cable
OMRON Corporation	V520-RH21-6 (With dedicated cable)	V509-W012	S8VS-03005(A 100VAC plug cable must be purchased separately.)	Produced by the user Refer to 1) below.
Motorola Solutions, Inc.	LS2208	CBA-R01-S07PAR	symbol 50-14000-101R	Not necessary

- *1 When using a barcode reader, follow one of the procedures below to turn on it.
- Turn on the GOT, wait 2 seconds or more, and turn on the barcode reader.
 - Turn on the GOT, wait for the startup logo to appear, and turn on the barcode reader.
- If you use any procedure other than the above and the barcode reader becomes inoperable, restart the barcode reader.

1) Cable connection diagram for a barcode reader manufactured by OMRON Corporation
 The following shows connection cables that must be produced by the user.
 Maximum cable length: confirm with the barcode reader manufacturer.

Barcode reader			Cable connection and signal direction	GOT	
Signal direction	Signal name	Pin No.		Pin No.	Signal name
Internal connection	FG	1		1	CD
	SD(TXD) *1	2		2	RD(RXD)
	RD(RXD) *1	3		3	SD(TXD)
	RS(RTS)	4		4	ER(DTR)
	CS(CTS)	5		5	SG
	—	6		6	DR(DSR)
	—	7		7	RS(RTS)
	—	8		8	CS(CTS)
	SG	9		9	—

*1 A dedicated cable, V509-W012 (cross cable), is used between the barcode reader and the cables mentioned above. Even if the signal name for cable connection is SD-SD or RD-RD, the communication can be performed with no problem.

3.2.3 System equipment (3)

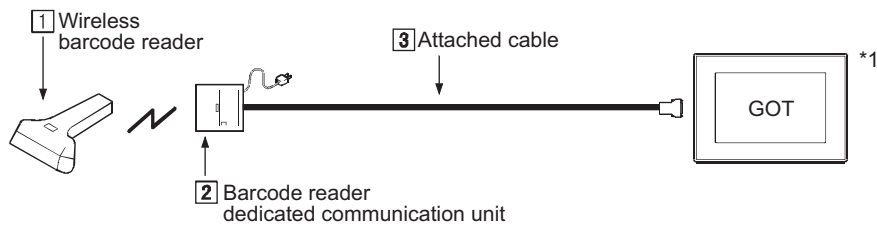

Manufacturer	1 Wireless barcode reader	2 Barcode reader dedicated communication unit	3 Attached cable
Nippon Systems Development Co.,Ltd.	AC-812-000-D1 PDC-812-400-00+PDC-812-300-D1	Included with a barcode reader	Included with a barcode reader

*1 When using a barcode reader, follow one of the procedures below to turn on it.
 · Turn on the GOT, wait 2 seconds or more, and turn on the barcode reader.
 · Turn on the GOT, wait for the startup logo to appear, and turn on the barcode reader.
 If you use any procedure other than the above and the barcode reader becomes inoperable, restart the barcode reader.

3.2.4 System equipment (4)

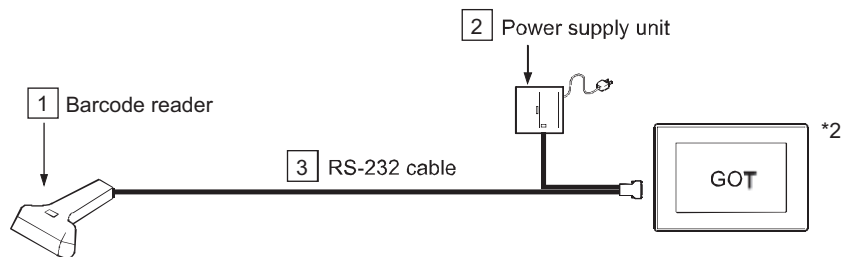

Manufacturer	1 Barcode reader	2 Power supply unit	3 RS-232 cable
IDEC AUTO-ID SOLUTIONS Corporation	QD2130-□□ *3	11-0387 or UL310-0515 *3	CAB-350 *1
	QD2131-□□		
	QD4130-□□	11-0387	8-0736-80 *1
	MG1100i-1D		
	PD7130-YB-PTR	SET8-0935	CAB-433 *1
OPTOELECTRONICS CO.,LTD.	OPL-6845R-RS232	Included with a barcode reader	Included with a barcode reader *1
KEYENCE CORPORATION	HR-50R	Included with a barcode reader	Included with a barcode reader *1
Honeywell International Inc	3800G-04E	An adapter must be purchased separately.	Included with a barcode reader
AIMEX Corporation	Z-3220	An adapter must be purchased separately.	Included with a barcode reader

*1 To connect the barcode reader to GT SoftGOT2000, connect the following USB/RS-232 conversion cables to a USB port on the personal computer.

For the USB/RS-232 conversion cables, refer to Technical Bulletin FA-D-0036.

- DIFC-U2 (Diatrend Corporation)
- DAC01R2VD (Diatrend Corporation)

<Connection example>

[Barcode reader (RS-232)] + [3 RS-232 cable] + [DAC01R2VD] + [DIFC-U2] + [Personal computer (USB)]

*2 When using a barcode reader, follow one of the procedures below to turn on it.

- Turn on the GOT, wait 2 seconds or more, and turn on the barcode reader.
- Turn on the GOT, wait for the startup logo to appear, and turn on the barcode reader.

If you use any procedure other than the above and the barcode reader becomes inoperable, restart the barcode reader.

*3 This is a discontinued product.

3.2.5 System equipment (5)

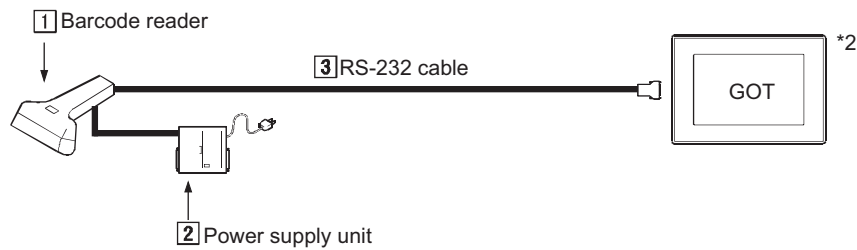

Manufacturer	1 Barcode reader	2 Power supply unit	3 RS-232 cable
IDEC AUTO-ID SOLUTIONS Corporation	GBT4130-BK-BT	SET8-0935 or PSAA18U-120	CAB-350 *1

*1 To connect the barcode reader to GT SoftGOT2000, connect the following USB/RS-232 conversion cables to a USB port on the personal computer.

For the USB/RS-232 conversion cables, refer to Technical Bulletin FA-D-0036.

- DIFC-U2 (Diatrend Corporation)
- DAC01R2VD (Diatrend Corporation)

<Connection example>

[Barcode reader (RS-232)] + [3 RS-232 cable] + [DAC01R2VD] + [DIFC-U2] + [Personal computer (USB)]

*2 When using a barcode reader, follow one of the procedures below to turn on it.

- Turn on the GOT, wait 2 seconds or more, and turn on the barcode reader.
- Turn on the GOT, wait for the startup logo to appear, and turn on the barcode reader.

If you use any procedure other than the above and the barcode reader becomes inoperable, restart the barcode reader.

3.2.6 System equipment (6)

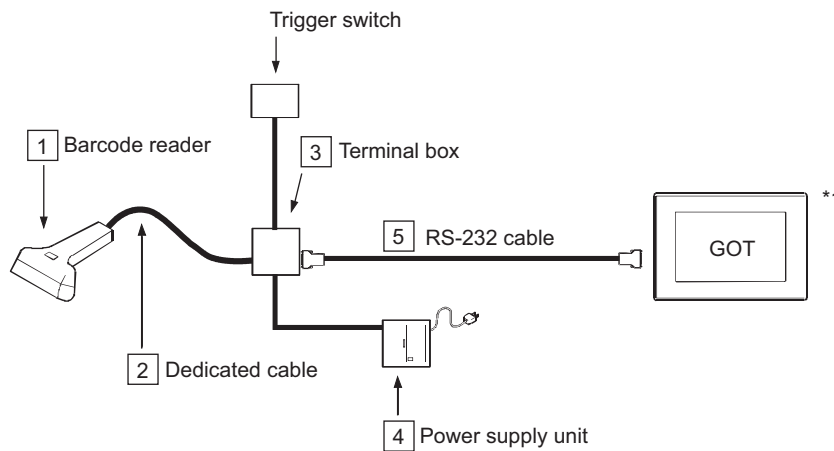

Manufacturer	1 Barcode reader	2 Dedicated cable	3 Terminal box	4 Power supply unit	5 RS-232 cable
IDEC AUTO-ID SOLUTIONS Corporation	DS2100N-□□□□ DS2400N-□□□□ DS4800-1□00	Included with a barcode reader	CBX100	PS5R-B24	Produced by the user Refer to 1) below.

*1 When using a barcode reader, follow one of the procedures below to turn on it.

- Turn on the GOT, wait 2 seconds or more, and turn on the barcode reader.
- Turn on the GOT, wait for the startup logo to appear, and turn on the barcode reader.

If you use any procedure other than the above and the barcode reader becomes inoperable, restart the barcode reader.

[Issue No.] GOT-A-0064-AD

1) RS-232 cable connection diagram for a barcode reader manufactured by IDEC AUTO-ID SOLUTIONS Corporation.

The following shows connection cables that must be produced by the user.

Maximum cable length: confirm with the barcode reader manufacturer.

Barcode reader		Cable connection and signal direction	GOT	
Signal name	Pin No.		Pin No.	Signal name
SGND	—		1	CD
TX	—		2	RD(RXD)
RTS	—		3	SD(TXD)
RX	—		4	ER(DTR)
CTS	—		5	SG
—	—		6	DR(DSR)
—	—		7	RS(RTS)
—	—		8	CS(CTS)
—	—		9	NC

3.2.7 System equipment (7)

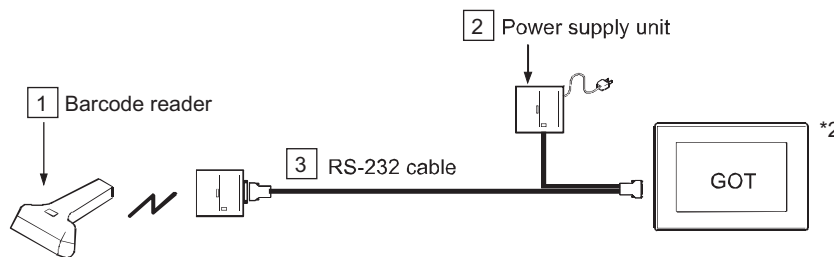

Manufacturer	1 Barcode reader	2 Power supply unit	3 RS-232 cable
DENSO WAVE INCORPORATED	GT10B-SB	Included with a barcode reader (A Bluetooth adapter (BA-10RKU) must be purchased separately.)	CBBA-RS2000/9 *1

*1 To connect the barcode reader to GT SoftGOT2000, connect the following USB/RS-232 conversion cables to a USB port on the personal computer.

For the USB/RS-232 conversion cables, refer to Technical Bulletin FA-D-0036.

- DIFC-U2 (Diatrend Corporation)
- DAC01R2VD (Diatrend Corporation)

<Connection example>

[Barcode reader (RS-232)] + [3 RS-232 cable] + [DAC01R2VD] + [DIFC-U2] + [Personal computer (USB)]

*2 When using a barcode reader, follow one of the procedures below to turn on it.

- Turn on the GOT, wait 2 seconds or more, and turn on the barcode reader.
- Turn on the GOT, wait for the startup logo to appear, and turn on the barcode reader.

If you use any procedure other than the above and the barcode reader becomes inoperable, restart the barcode reader.

3.2.8 System equipment (8)

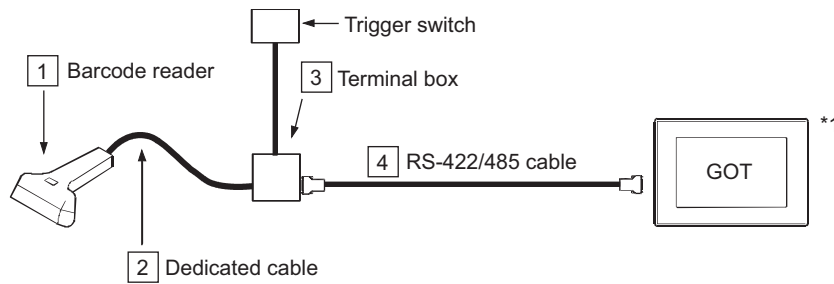

Manufacturer	1 Barcode reader	2 Dedicated cable	3 Terminal box	4 RS-422/485 cable
IDEC AUTO-ID SOLUTIONS Corporation	DS2100N-1214	Included with a barcode reader	CBX100	Produced by the user Refer to 1) below.

*1 When using a barcode reader, follow one of the procedures below to turn on it.

- Turn on the GOT, wait 2 seconds or more, and turn on the barcode reader.
- Turn on the GOT, wait for the startup logo to appear, and turn on the barcode reader.

If you use any procedure other than the above and the barcode reader becomes inoperable, restart the barcode reader.

1) RS-422/485 cable connection diagram for a barcode reader manufactured by IDEC AUTO-ID SOLUTIONS Corporation.

a) For connection using the RS-422/485 interface of the GOT or GT15-RS4-9S

The following shows connection cables that must be produced by the user.

Maximum cable length: confirm with the barcode reader manufacturer.

For GT2104-R, GT2104-P, or GT2103-P, check the signal names and connect the cables.

Barcode reader		Cable connection and signal direction	GOT	
Signal name	Pin No.		Pin No.	Signal name
—	—		1	SDA
TX(+)	2	→	2	RDA
RX(+)	3	←	3	RSA *1
TX(-)	4	→	4	CSA *1
RX(-)	5	←	5	SG
—	—		6	SDB
SGND	7	←	7	RDB
—	—		8	RSB *1
—	—		9	CSB *1

*1 Not provided for GT2104-PMBD and GT2103-PMBD; therefore, loopback connection is unnecessary.

[Issue No.] GOT-A-0064-AD

b) For connection using GT15-RS4-TE
 The following shows connection cables that must be produced by the user.
 Maximum cable length: confirm with the barcode reader manufacturer.

Barcode reader		Cable connection and signal direction	GOT	
Signal name	Pin No.		Pin No.	Signal name
—	—		1	SDA1
TX(+)	2	→	2	SDB1
RX(+)	3	←	3	RDA1
TX(-)	4	→	4	RDB1
RX(-)	5	←	5	SDA2
—	—		6	SDB2
SGND	7	→	7	RDA2
—	—		8	RDB2
—	—		9	SG
—	—		10	FG

3.2.9 System equipment (9)

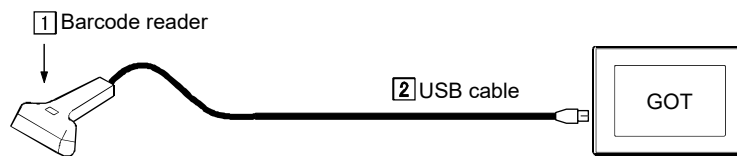

Manufacturer	1 Barcode reader	2 USB cable
IDEC AUTO-ID SOLUTIONS Corporation	QD2131	·90A052065 (2 m) ·90A052095 (4 m)
	GD4130-WH	·CAB-412 (with an adapter jack) and 11-0387 (AC adapter) ·CAB-426E (without an adapter jack)
Aug, Inc.	AUG-500SDW-USB(HID)	Included with a barcode reader
OPTOELECTRONICS CO.,LTD.	OPL-6845V	Included with a barcode reader
	L-46R-V-WHT-USB	
KEYENCE CORPORATION	HR-100	·HR-1C3UN (3 m)
		·HR-1C3UC (3 m, curl type)
		·HR-1C5UC (5 m, curl type)
DENSO WAVE INCORPORATED	HC56TU	Included with a barcode reader
MARS TOHKEN SOLUTION CO.LTD.	THLS-7800U	Included with a barcode reader
NICHIEI INTEC CO., LTD.	FFTA21BU	Included with a barcode reader
	FFTA10AUSB	
Zebra Technologies, Inc.	LS2208	Included with a barcode reader
SICK Inc.	IDM240-100H *1	Included with a barcode reader
Honeywell International Inc.	Xenon 1900GSR-1	Included with a barcode reader

*1 GT27 / GT25-W / GT2505-V are supported with CoreOS version V or later and GT 23 with CoreOS version N or later. Not supported by GT21-W.

3.2.10 System equipment (10)

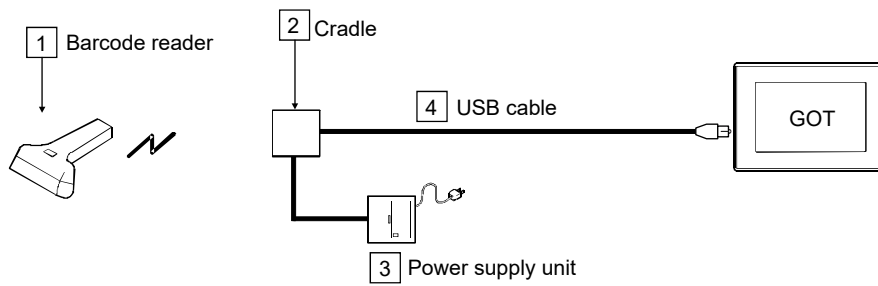

Manufacturer	1 Barcode reader	2 Cradle	3 Power supply unit	4 USB cable
Unitech Electronics Co., LTD.	MS840BT	5000-900007G	1010-900008G	1550-900040G

3.3 Compatible barcode types

The following barcode reader communication settings are supported by the GOT.

○: Can be read in the GOT, △: Partly restricted, ×: Unreadable in GOT

Manufacturer	Barcode reader	Barcode type									
		UPC)	WPC (JAN, EAN, EAN)	CODE-39	CODE-93	CODE-128	NW-7 (CODABAR)	2of5 (Industrial)	ITF (2of5Interleaved)	MSI/Plessey	IATA 2of5
AIMEX Corporation	BR-530RS-B1	○	○	○	○	○	○	×	○	×	×
	BW-880RS-B1	○	○	○	○	○	○	○	○	○	×
	Z-3220	○	○	○	○	○	○	×	○	×	×
IDEC AUTO-ID SOLUTIONS Corporation	DS2200-1100	○	○	○	○	○	○	×	○	×	×
	DS2100-1114 *2	○	○	○	○	○	○	×	○	×	×
	GRYPHON D100 *2	○	○	○	○	○	○	○	○	○	×
	GRYPHON D130 *2	○	○	○	○	○	○	○	○	×	×
	DS2100N-□□□□	○	○	○	○	○	○	×	○	×	×
	DS2400N-□□□□	○	○	○	○	○	○	○	○	○	○
	DS4800-1□00	○	○	○	○	○	○	○	○	○	○
	QD2130-□□	○	○	○	○	○	○	○	○	○	○
	DQ4130-□□	○	○	○	○	○	○	○	○	○	○
	GBT4130-BK-BT	○	○	○	○	○	○	○	○	○	○
	MG1100i-1D	○	○	○	○	○	○	○	○	○	○
	PD7130-YB-PTR	○	○	○	○	○	○	○	○	○	○
	QD-2131	○	○	○	○	○	○	×	○	×	×
	GD4130	○	○	○	○	○	○	×	○	×	×
NEC Platforms, Ltd.	BCH5542-STA	○	○	○	○	○	○	○	○	×	×
	BCR5342H-STZ	○	○	○	○	○	○	○	○	×	×
OMRON Corporation Aug, Inc.	V520-RH21-6	○	○	○	○	○	○	×	○	×	×
	AUG-500SDW-USB(HID)	○	○	○	○	○	○	○	○	○	×
OPTOELECTRONICS CO.,LTD.	OPT-5125-RS232C(H)	○	○	○	○	○	○	○	○	○	×
	OPL-6735-RS232C(X04)	○	○	○	○	○	○	○	○	○	×
	NFT-7175-RS-1	○	○	○	○	○	○	○	×	○	×
	OPL-6845R-RS232	○	○	○	○	○	○	○	×	×	○
	OPL-6845V	○	○	○	○	○	○	○	○	○	○
KEYENCE CORPORATION	L-46R-V-WHT-USB	○	○	○	○	○	○	○	○	○	○
	BL-210R	○	○	○	○	○	○	○	○	×	×
	BL-210RK	○	○	○	○	○	○	×	×	×	×
	BL-601	○	○	○	○	○	○	○	○	×	×
	BL-N70R	○	○	○	○	○	○	×	○	○	×
	SR-510	○	○	○	○	○	○	○	○	×	×
	HR-50R	○	○	○	○	○	○	○	○	×	×
DENSO WAVE INCORPORATED	HR-100	○	○	○	○	○	○	○	○	○	○
	GT10B-SB	○	○	○	○	○	○	○	○	○	×
MARS TOHKEN SOLUTION CO.LTD.	HC56TU	○	○	○	○	○	○	○	○	×	×
	TLMS-3500RV	△ *1	○	×	○	○	×	○	×	×	×
	THLS-6712	○	○	○	○	○	○	×	○	×	×
	THLS-6800	○	○	○	○	○	○	×	○	×	×
NICHIEI INTEC CO., LTD.	THLS-7800U	○	○	○	○	○	○	○	○	○	×
	FFTA21BU	○	○	○	○	○	○	○	○	○	×
Nippon Systems Development Co.,Ltd.	FFTA10AUSB	○	○	○	○	○	○	○	○	×	×
	AC-812-000-D1	○	○	×	○	○	○	○	○	×	×
Motorola Solutions, Inc.	LS2208	○	○	○	○	○	○	×	○	×	×
	LI4278	○	○	○	○	○	○	○	○	○	○
Unitech Electronics Co., LTD.	MS840BT	○	○	○	○	○	○	×	○	○	×
Honeywell International Inc.	3800G-04E	○	○	○	○	○	○	×	○	×	○
Zebra Technologies, Inc.	LS2208	○	○	○	○	○	○	×	○	○	○

*1 Only JAN is supported.

*2 This is a discontinued product.

3.4 How to read data by a barcode reader

Please refer to the followings for the data transfer format (header/terminator settings and others) that can be used in the GOT or the setting method to read data by a barcode reader.

- Data transfer format (header/terminator settings and others) that can be used in the GOT.
- Setting to connect a barcode reader to the GOT. ([Peripheral Setting] on GT Designer3(GOT2000))
- Setting to write the data, read by a barcode reader, to the PLC CPU. ([Detail Setting] in the [Bar Code] dialog box on GT Designer3(GOT2000))

Refer to the following.

⇒ GT Designer3 (GOT2000) Screen Design Manual (SH-081220ENG)

- Setting procedure from connecting a barcode reader to the GOT until reading a barcode.

Refer to the following.

⇒ GOT2000 Series Connection Manual (Microcomputers, MODBUS/Fieldbus Products, Peripherals) For GT Works3 Version1 (SH-081200ENG)

3.5 When using the GT21 model

To connect the barcode reader with the built-in RS-232 port (on the back side) of GT2103-PMBDS or GT2103-PMBDS2, use the cable GT10-C02H-6PT9P.

To use GT2104-R, refer to the following and fabricate a cable for connecting the GOT.

■ User cable

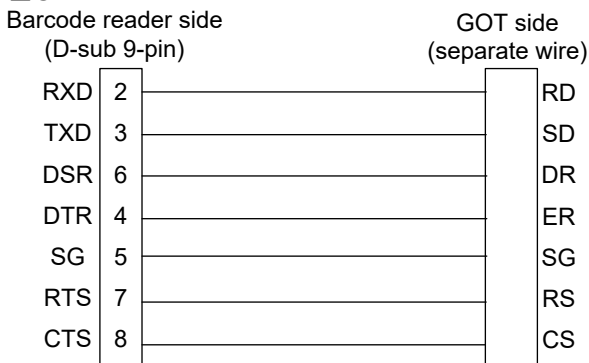

[Issue No.] GOT-A-0064-AD

4. 2D Code Reader

4.1 Compatible Products

4.1.1 RS-232 connection

○: Supported, ×: Not supported, -: Not validated

Manufacturer	Model	Operation validation		Reference
		GOT2000	GT SoftGOT2000	
AIMEX Corporation	IT4600SR-RS	○	○	4.2.1
	MATRIX210-21□-□□□	○	○	4.2.4
	MATRIX300-□□□-□□□	○	○	
	MATRIX410-□□□-0□0	○	○	
	MATRIX210N-21□-□□□	○	○	
IDEC AUTO-ID SOLUTIONS Corporation	GD4430-□□	○	○	4.2.3
	GD4430-□□-HD	○	○	
	GBT4430-□□	○	○	
	MG1100i-2D	○	○	
	M3200i Series	○	○	
	QD2430-□□	○	○	4.2.2
	GFS4450-9	○	○	
	GD4590-□□	○	○	
	PD9531-HP	○	○	
	GFS4450-9	○	○	
	PBT9500-HPRB	○	○	
GBT4500-WH-WLC	○	○		
OMRON Corporation	V400-F250	○	○	4.2.1
OPTOELECTRONICS CO.,LTD.	OPD-7435	○	○	4.2.1
	NFD1267 *1	○	×	
	OPI-3601-V	○	○	4.2.3
	L-22X-V-WHT	○	○	
KEYENCE CORPORATION	L-46X-OCR3.0-V-WHT	○	○	4.2.5
	TL-30	○	○	4.2.1
	TL-40	○	○	
DENSO WAVE INCORPORATED	SR-510	○	○	4.2.1
	HR-100	○	○	4.2.12
	SR-G100	○	○	
	GT10Q-SB	○	○	4.2.2
	GT10Q-SR	○	○	4.2.1
	GT11Q-SR	○	○	
	QB20K *1	○	×	
QD20	○	○	4.2.3	
AT10Q-SM	○	○		
AT20Q-SM	○	○		
AT21Q-SM	○	○		
AT25Q-SM	○	○		
AT26Q-SM	○	○		
AT27Q-SB	○	○	4.2.2	
AT30Q-SM	○	○	4.2.3	
MARS TOHKEN SOLUTION CO.LTD.	THIR-3000N	○	○	4.2.1
	THIR-6000	○	○	
	TFIR-31	○	○	
	THIR-6200DDM	○	○	
	THIR-6780R	○	○	4.2.3
MCR-H200	○	○		
Cognex K.K.	DataMan 100	○	○	4.2.1
	DataMan 7500/7500LR	○	○	
	DataMan 7550/7550LR	○	○	
	DataMan 750/750S	○	○	4.2.3
	DataMan 8100/8500	○	○	4.2.6
	DataMan 200 *2	○	○	
	DataMan 8050	○	○	4.2.3
	DataMan 8600	○	○	
	DataMan 474X/475X	○	○	
DataMan 8072□□	○	○		
Motorola Solutions, Inc.	DS6608-RS-DOS/V	○	○	4.2.1
Honeywell International Inc.	1900GSR-2	○	○	4.2.3
	1470g	○	○	
Mitsubishi Electric Corporation	CF26-SR	○	○	4.2.3
	CF26-LR	○	○	
CodeReader-JP Corporation	CodeReader 1500	○	○	4.2.3

[Issue No.] GOT-A-0064-AD

- *1 GT27 model and GT25 model are available only. (5VDC is required.)
- *2 Configure the communication settings of the DataMan 200 and the GOT as shown below.

Setting item	Set value
Baud rate	115200 bps
Data length	8 bits or 7 bits
Stop bit	None, Even number or odd number
Parity	1 bit or 2 bits

4.1.2 RS-422/485 connection

○: Supported, ×: Not supported, -: Not validated

Manufacturer	Model	Operation validation		Reference
		GOT2000	GT SoftGOT2000	
IDEC AUTO-ID SOLUTIONS Corporation	MATRIX210N-21□-□□□	○	×	4.2.7

4.1.3 USB connection

○: Supported, ×: Not supported, -: Not validated

Manufacturer	Model	Operation validation		Reference
		GOT2000	GT SoftGOT2000	
IDEC AUTO-ID SOLUTIONS Corporation	QD2430-□□	○	×	4.2.8
	GD4430-□□	○	×	
	Magellan1100i-2D	○	×	
	Magellan3200i	○	×	
	GD4590-WH ^{*2}	○	×	
	PD9531-HP ^{*3}	○	×	
	GFS4470 ^{*3}	○	×	
	PBT9500-HPRB	○	×	4.2.9
	GBT4500-WH-WLC	○	×	
DENSO WAVE INCORPORATED	AT20Q-SM	○	○	4.2.8
	AT30Q-SM	○	×	
	AT31Q-SM	○	×	
	GT20Q-SM	○	×	
	SH1-QU	○	○	
Cognex K.K.	GT20Q-SB	○	×	4.2.9
	DataMan 70S	○	○	
	DataMan 8050 ^{*4*5}	○	○	
	DataMan 8050X	○	○	
	DataMan 8600	○	○	
	DataMan 8072□□	○	○	4.2.10
	DataMan 8700DX	○	○	
Zebra Technologies, Inc.	DS6707-HD	○	×	4.2.8
SICK Inc.	IDM240-100H ^{*1}	○	×	4.2.8
Honeywell International Inc.	Xenon 1900GSR-1	○	○	4.2.8
	Xenon 1902GSR-1	○	○	4.2.9
	1470g	○	○	4.2.8
1950g	○	○		
MARS TOHKEN SOLUTION CO.,LTD	THIR-6780U	○	○	4.2.8
	MCR-H200	○	○	
KEYENCE CORPORATION	HR-100	○	○	4.2.8
	SR-G100	○	○	4.2.11
OPTOELECTRONICS CO.,LTD.	L-22X-V-WHT	○	○	4.2.8
	L-46X-OCR3.0-V-WHT	○	○	

- *1 Supported by GT27/GT25-W/GT2505-V with CoreOS version V or later and GT23 with CoreOS version N or later. Not supported by GT21-W.
- *2 Supported by GT27/GT25 with CoreOS version Y or later. Not supported by GT2505-V and GT21-W.
- *3 Not supported by GT21-W.
- *4 For the hardware versions of GT27 and GT25 that support the model, refer to the following.
 - 1) Hardware versions and dates of manufacture of the GOTs that support DataMan8050
 Not supported by GT2505-V, GT25HS-V, and GT21-W.
 When the model is used with GT2507T-W, the operating ambient temperature must be 55°C or lower.
 When the model is used with GT2705-V, the total current consumed by the extension units, bar code reader, and RFID controller must be within 1.0 A.
 For how to calculate the current, refer to the following.
 →GOT2000 Series User's Manual (Hardware) (SH-081194ENG)
- *5 When using the model with GT SoftGOT2000, connect the USB cable of the barcode reader to the USB 3.0 port on the personal computer.

[Issue No.] GOT-A-0064-AD

When data is input from a 2D code reader, the GOT supports only the ASCII code characters that can be output using a USB keyboard.

The GOT ignores data that cannot be output in the ASCII code.

When you use the above models, the USB keyboard function is available. (The input value is processed as the ASCII code.)

For the usage instructions, refer to the following.

→ GT Designer3 (GOT2000) Screen Design Manual (SH-081220ENG)

1) Hardware versions and dates of manufacture of the GOTs that support DataMan8050

DataMan8050 is supported by the GOTs whose hardware versions and dates of manufacture are as shown below.

GOT	Model	LCD	Hardware version	Date of manufacture	Remarks	
GT27	GT2715-XTBA	15" XGA	F	August 2021 or later	-	
	GT2715-XTBD		F		-	
	GT2715-XTBA-GF		F **		GOT with GT15-J71GF13-T2 (set)	
	GT2715-XTBD-GF		F **			
	GT2712-STBA	12.1" SVGA	W			-
	GT2712-STBD		U		-	
	GT2712-STWA		T		-	
	GT2712-STWD		R		-	
	GT2712-STBA-GF		W **		GOT with GT15-J71GF13-T2 (set)	
	GT2712-STBD-GF		U **			
	GT2712-STWA-GF		T **			
	GT2712-STWD-GF		R **			
	GT2710-STBA	10.4" SVGA	V		-	
	GT2710-STBD		W	-		
	GT2710-STBA-GF		V **	GOT with GT15-J71GF13-T2 (set)		
	GT2710-STBD-GF		W **			
	GT2710-VTBA	10.4" VGA	Y		-	
	GT2710-VTBD		Z	-		
	GT2710-VTWA		U	-		
	GT2710-VTWD		V	-		
	GT2710-VTBA-GF		Y **	GOT with GT15-J71GF13-T2 (set)		
	GT2710-VTBD-GF		Z **			
	GT2710-VTWA-GF		U **			
	GT2710-VTWD-GF		V **			
	GT2708-STBA		8.4" SVGA	M		-
	GT2708-STBD			M	-	
	GT2708-STBA-GF	M **		GOT with GT15-J71GF13-T2 (set)		
	GT2708-STBD-GF	M **				
	GT2708-VTBA	8.4" VGA	M		-	
	GT2708-VTBD		M	-		
GT2708-VTBA-GF	M **		GOT with GT15-J71GF13-T2 (set)			
GT2708-VTBD-GF	M **					
GT2705-VTBD	5.7" VGA	Y		-		
GT2705-VTBD-GF		Y **	GOT with GT15-J71GF13-T2 (set)			
GT25	GT2512-WXTSD	12.1" WXGA	A	February 2021 or later	Wide model	
	GT2512-WXTBD		A			
	GT2512-STBA	12.1" SVGA	W	August 2021 or later	-	
	GT2512-STBD		V		-	
	GT2512-STBA-GF		W **		GOT with GT15-J71GF13-T2 (set)	
	GT2512-STBD-GF		V **			
	GT2512F-STNA		F		Open frame model	
	GT2512F-STND		F			
	GT2510-WXTSD	10.4" WXGA	L	February 2021 or later	Wide model	
	GT2510-WXTBD		L			

[Issue No.] GOT-A-0064-AD

GOT	Model	LCD	Hardware version	Date of manufacture	Remarks		
GT25	GT2510-VTBA	10.4" VGA	Z	August 2021 or later	-		
	GT2510-VTBD		A		-		
	GT2510-VTWA		T		-		
	GT2510-VTWD		U		-		
	GT2510-VTBA-GF		Z ^{*1}		GOT with GT15-J71GF13-T2 (set)		
	GT2510-VTBD-GF		A ^{*1}				
	GT2510-VTWA-GF		T ^{*1}				
	GT2510-VTWD-GF		U ^{*1}				
	GT2510F-VTNA		8.4" VGA		E	Open frame model	
	GT2510F-VTND				E		
	GT2508-VTBA	T		-			
	GT2508-VTBD	T		-			
	GT2508-VTWA	7.0" WVGA	R	February 2021 or later	-		
	GT2508-VTWD		R		-		
	GT2508-VTBA-GF		T ^{*1}		GOT with GT15-J71GF13-T2 (set)		
	GT2508-VTBD-GF		T ^{*1}				
	GT2508-VTWA-GF		R ^{*1}				
	GT2508-VTWD-GF		R ^{*1}				
	GT2508F-VTNA		7.0" WVGA		C	Open frame model	
	GT2508F-VTND				C		
	GT2507-WTSD				H		Wide model
	GT2507-WTBD				H		
	GT2507T-WTSD	J	August 2021 or later	Rugged model			

*1 Check the hardware version of the GOT.

2) How to check the hardware versions and dates of manufacture of the GOTs that support DataMan8050
Check the rating plate of the GOT for its hardware version and the date of manufacture.

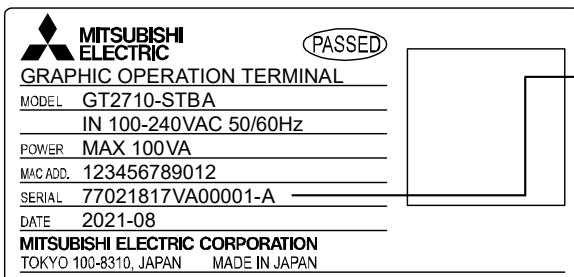

GOT serial number

7 7 0 2 1 8 1 7 V A 0 0 0 0 1 - A

BootOS version at factory default

Hardware version

Manufacturing date

Manufacturing month
(1 to 9: manufacturing month,
X: October, Y: November, Z: December)
Manufacturing year
(lower two digits of the year of grace)

4.2 System equipment of 2D code reader

The following shows the equipment to configure with different types of 2D code readers.

4.2.1 System equipment (1)

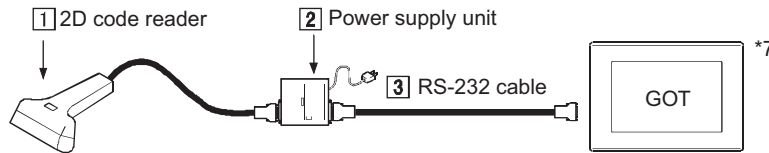

Manufacturer	1 2D code reader	2 Power supply unit	3 RS-232 cable
AIMEX Corporation	IT4600SR-RS	Included with a 2D code reader	Included with a 2D code reader
OMRON Corporation	V400-F250	Not necessary **2	Purchased by the user (V400-W24) Including a 24VDC power cable
OPTOELECTRONICS CO.,LTD.	OPD-7435	Included with a 2D code reader	Included with a 2D code reader
	NFD1267	Not necessary *3	Produced by the user Refer to 1) below. (5VDC is required.)
	OPI-3601-V	Included with a 2D code reader	Included with a 2D code reader
KEYENCE CORPORATION	TL-30	TL-U1	For GT27and GT25, refer to 2) below. GT21 when used, use the cable to the 2D code reader is shipped
	TL-40	TL-U1	Included with a 2D code reader
	SR-510	BL-U2	GT01-C30R2-9S *4
	HR-100	OP-87530	HR-1C3RC
DENSO WAVE INCORPORATED	GT10Q-SR	AD1005/3600	GT27, GT25, GT21: ·CBG1-RS2000/9 ·CBG1-RS5000/9-1 ·GT10Q RS232C/2m Curl SoftGOT2000: *5
	GT11Q-SR	AD1005/3600	CBG11-RS2000/9
	QB20/20-HD	2000639	496800-0040
	QB20K	Included with a 2D code reader	Included with a 2D code reader
	QD20	Not necessary **2	Produced by the user Refer to 3) below.
MARS TOHKEN SOLUTION CO.LTD.	THIR-3000N	S-8440	Included with a 2D code reader *5 *6
	TFIR-3102	Not necessary *1	Produced by the user Refer to 4) below.
	THIR-6000	Included with a 2D code reader	Included with a 2D code reader
	TFIR-31	Included with a 2D code reader	Included with a 2D code reader
	THIR-6200DDM	Included with a 2D code reader	Included with a 2D code reader
	THIR-6780R	Included with a 2D code reader	Included with a 2D code reader
Cognex K.K.	DataMan 100	DM100-RWR-000	DM100-RS232-000
	DataMan 7500	Included with a 2D code reader	DM42206139-04
	DataMan 7550	Included with a 2D code reader	DM42203758-03S
Motorola Solutions, Inc.	DS6608-RS-DOS/V	Included with a 2D code reader	Included with a 2D code reader *5

*1 It is necessary to supply 24VDC to the 2D code reader separately. For details, please refer to the manual of the 2D code reader to be used.

*2 For adjusting settings of the 2D code reader by using the monitor, please refer to the manual of the 2D code reader to be used.

*3 It is necessary to supply 5VDC to the 2D code reader separately. For details, please refer to the manual of the 2D code reader to be used.

*4 This is a Mitsubishi Electric product. Please contact your local Mitsubishi Electric or representative for purchasing the cable.

*5 To connect the 2D code reader to GT SoftGOT2000, connect the following USB/RS-232 conversion cables to a USB port on the personal computer.

For the USB/RS-232 conversion cables, refer to Technical Bulletin FA-D-0036.

- DIFC-U2 (Diatrend Corporation)

- DAC01R2VD (Diatrend Corporation)

<Connection example>

[2D code reader (RS-232)] + [3] RS-232 cable] + [DAC01R2VD] + [DIFC-U2] + [Personal computer (USB)]

*6 With the USB/RS-232 conversion cables (DIFC-U2 and DAC01R2VD), configure the 2D code reader setting so that the RS/CS control is not performed.

[Issue No.] GOT-A-0064-AD

- *7 When using a 2D code reader, follow one of the procedures below to turn on it.
- Turn on the GOT, wait 2 seconds or more, and turn on the 2D code reader.
 - Turn on the GOT, wait for the startup logo to appear, and turn on the 2D code reader.
- If you use any procedure other than the above and the 2D code reader becomes inoperable, restart the 2D code reader.

1) RS-232 cable connection diagram for a 2D code reader manufactured by OPTOELECTRONICS CO., LTD.
 The following shows connection cables that must be produced by the user.
 Maximum cable length: confirm with the 2D code reader manufacturer.

2D code reader		Cable connection and signal direction	GOT	
Signal name	Pin No.		Pin No.	Signal name
Trigger	Green		1	CD
OK-	Yellow		2	RD(RXD)
NG	Blue		3	SD(TXD)
SD	Purple		4	DTR(ER)
RD	Orange		5	SG
RS	Brown		6	DSR(DR)
CS	Gray		7	RS(RTS)
+5V	Red		8	CS(CTS)
GND	White		9	5V

2) RS-232 cable connection diagram for a 2D code reader manufactured by KEYENCE CORPORATION
 The following shows connection cables that must be produced by the user.
 Maximum cable length: confirm with the 2D code reader manufacturer.

2D code reader		Cable connection and signal direction	GOT	
Signal name	Pin No.		Pin No.	Signal name
N.C	1		1	CD
SD(TXD)	2		2	RD(RXD)
RD(RXD)	3		3	SD(TXD)
N.C	4		4	DTR(ER)
SG	5		5	SG
N.C	6		6	DSR(DR)
CS(CTS)	7		7	RS(RTS)
RS(RTS)	8		8	CS(CTS)
N.C	9		9	—

3) RS-232 cable connection diagram for a 2D code reader manufactured by DENSO WAVE INCORPORATED
 The following shows connection cables that must be produced by the user.
 Maximum cable length: confirm with the 2D code reader manufacturer.

2D code reader		Cable connection and signal direction	GOT	
Signal name	Pin No.		Pin No.	Signal name
—	—		1	CD
/TXD	2		2	RD(RXD)
/RXD	3		3	SD(TXD)
—	—		4	DTR(ER)
GND	5		5	SG
—	—		6	DSR(DR)
CTS	7		7	RS(RTS)
RTS	8		8	CS(CTS)
—	—		9	NC

[Issue No.] GOT-A-0064-AD

4) RS-232 cable connection diagram for a 2D code reader manufactured by MARS TOHKEN SOLUTION CO.LTD.

The following shows connection cables that must be produced by the user.
Maximum cable length: confirm with the 2D code reader manufacturer.

2D code reader		Cable connection and signal direction	GOT	
Signal name	Pin No.		Pin No.	Signal name
—	—		1	CD *1
RXD /RD-	2		2	RD(RXD)
TXD /TD+	3		3	SD(TXD)
—	—		4	DTR(ER)
GND	5		5	SG
—	—		6	DSR(DR)
—	—		7	RS(RTS)
RTS	11		8	CS(CTS)
CTS	12		9	—

4.2.2 System equipment (2)

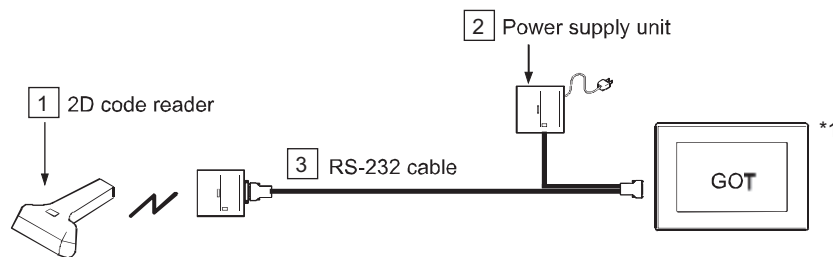

Manufacturer	1 2D code reader	2 Power supply unit	3 RS-232 cable
DENSO WAVE INCORPORATED	GT10Q-SB	Included with a 2D code reader (A Bluetooth adapter (BA10-RKU) must be purchased separately.)	CBBA-RS2000/9
	AT27Q-SB	Included with a 2D code reader (A Bluetooth adapter (BA20-RU) must be purchased separately.)	Included with a 2D code reader
IDEC AUTO-ID SOLUTIONS Corporation	PBT9500-HPRB	PSAA18U-120 (power cable: LS-13J)	CAB-459
	GBT4500-WH-WLC		90A051230

*1 When using a 2D code reader, follow one of the procedures below to turn on it.
 · Turn on the GOT, wait 2 seconds or more, and turn on the 2D code reader.
 · Turn on the GOT, wait for the startup logo to appear, and turn on the 2D code reader.
 If you use any procedure other than the above and the 2D code reader becomes inoperable, restart the 2D code reader.

4.2.3 System equipment (3)

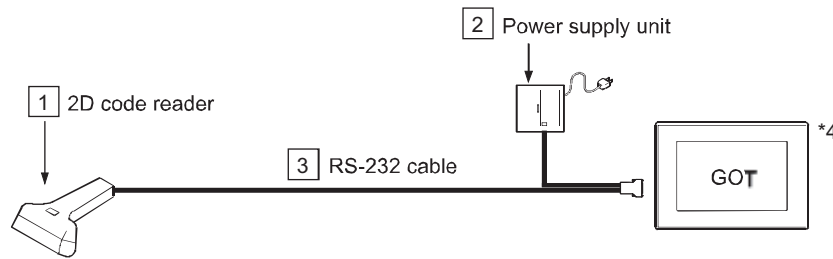

Manufacturer	1 2D code reader	2 Power supply unit	3 RS-232 cable
IDEC AUTO-ID SOLUTIONS Corporation	GD4430-□□	11-0387, UL310-0515 *5, or 5V power supply from the GOT standard interface *2	CAB-350 *3
	GD4430-□□-HD		
	GBT4430-□□	11-0387	8-0736-80 *3
	MG1100i-2D		
	M3200i Series	Included with a 2D code reader	8-0730-54 *3
	QD2430-□□	11-0387	CAB-350 *3
	GFS4450-9	11-0387	Included with a 2D code reader
	GD4590-□□	PSC15R-050	90A051230 *3
	PD9531-HP		CAB-459
GFS4450-9	Included with a 2D code reader		
DENSO WAVE INCORPORATED	AT10Q-SM	Included with a 2D code reader	Included with a 2D code reader
	AT20Q-SM		
	AT21Q-SM		
	AT25Q-SM		
	AT26Q-SM		
	AT30Q-SM		
Cognex K.K.	DataMan 750	DMA-24KIT-00, DM100-PWR-000	DM700-RS232-00
	DataMan 750S		
	DataMan 8100 *1	DM100-PWR-00	DM8000-RS232-00
	DataMan 8500 *1		
	DataMan 8050 *1	GT-41076-0609-3.0	DM8000-RS232-□□
	DataMan 8600 *1		
	DataMan 8072□□ *1		
Honeywell International Inc.	DataMan 474X/475X *1	CCB-PWRIO-05(R) *6	Included with a 2D code reader
	1900GSR-2	CCB-PWRIO-10(R) *6	
	1470g	CCB-PWRIO-15(R) *6	
Mitsubishi Electric Corporation	CF26-SR	CCB-PWRIO-05(R) *6	Included with a 2D code reader
	CF26-LR	CCB-PWRIO-10(R) *6	
CodeReader-JP Corporation	CodeReader 1500	CCB-PWRIO-15(R) *6	Included with a 2D code reader
MARS TOHKEN SOLUTION CO.LTD.	MCR-H200	Included with a 2D code reader	Included with a 2D code reader
OPTOELECTRONICS CO.,LTD.	L-22X-V-WHT	6A-161WP05-092	CRA-C502
	L-46X-OCR3.0-V-WHT	UF1-WB10E05R	UF1-HSCS20S5002-A-PAC
		UF1-WB10E05R	UF1-HSCG20S5002-A-PAC

*1 The communication module DMCN-SERIALM-00 is required.
 *2 It is necessary to supply 5VDC to the 2D code reader separately. For details, please refer to the manual of the 2D code reader to be used.
 *3 To connect the 2D code reader to GT SoftGOT2000, connect the following USB/RS-232 conversion cables to a USB port on the personal computer.
 For the USB/RS-232 conversion cables, refer to Technical Bulletin FA-D-0036.
 - DIFC-U2 (Diatrend Corporation)
 - DAC01R2VD (Diatrend Corporation)
 <Connection example>
 [2D code reader (RS-232)] + [3 RS-232 cable] + [DAC01R2VD] + [DIFC-U2] + [Personal computer (USB)]
 *4 When using a 2D code reader, follow one of the procedures below to turn on it.

[Issue No.] GOT-A-0064-AD

- Turn on the GOT, wait 2 seconds or more, and turn on the 2D code reader.
- Turn on the GOT, wait for the startup logo to appear, and turn on the 2D code reader.

If you use any procedure other than the above and the 2D code reader becomes inoperable, restart the 2D code reader.

*5 This is a discontinued product.

*6 It is necessary to supply 24VDC to the 2D code reader separately.

CCB-PWRIO-□□(R) is supplied with an RS-232 signal cable and 24 V DC power cable.

For how to wire the signal cable and the power cable, refer to the user's manual of the 2D code reader to be used.

4.2.4 System equipment (4)

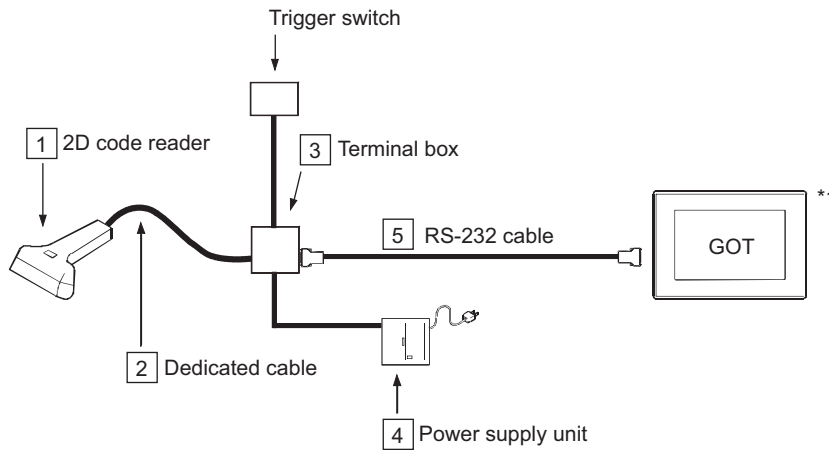

Manufacturer	1 2D code reader	2 Dedicated cable	3 Terminal box	4 Power supply unit	5 RS-232 cable
IDEC AUTO-ID SOLUTIONS Corporation	MATRIX210-21□-□□□	Included with a 2D code reader	CBX100	PS5R-B24	Produced by the user Refer to 1) below.
	MATRIX300-□□□-□□□	CAB-DS0□-S			
	MATRIX410-□□□-0□0	CAB-MS01			
	MATRIX210N-21□-□□□	Included with a 2D code reader			

*1 When using a 2D code reader, follow one of the procedures below to turn on it.

- Turn on the GOT, wait 2 seconds or more, and turn on the 2D code reader.
- Turn on the GOT, wait for the startup logo to appear, and turn on the 2D code reader.

If you use any procedure other than the above and the 2D code reader becomes inoperable, restart the 2D code reader.

1) RS-232 cable connection diagram for a 2D code reader manufactured by IDEC AUTO-ID SOLUTIONS Corporation.

The following shows connection cables that must be produced by the user.

Maximum cable length: confirm with the barcode reader manufacturer.

Barcode reader		Cable connection and signal direction	GOT	
Signal name	Pin No.		Pin No.	Signal name
SGND	—	←	1	CD
TX	—	→	2	RD(RXD)
RTS	—	→	3	SD(TXD)
RX	—	←	4	ER(DTR)
CTS	—	→	5	SG
—	—		6	DR(DSR)
—	—		7	RS(RTS)
—	—		8	CTS
—	—		9	NC

4.2.5 System equipment (5)

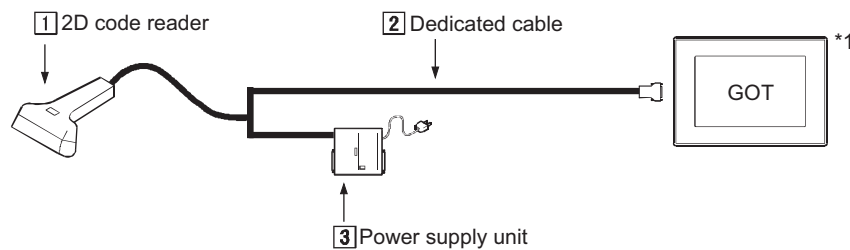

Manufacturer	1 2D code reader	2 Dedicated cable	3 Power supply unit
KEYENCE CORPORATION	TL-30	Included with a 2D code reader	TL-U1

*1 When using a 2D code reader, follow one of the procedures below to turn on it.

- Turn on the GOT, wait 2 seconds or more, and turn on the 2D code reader.
- Turn on the GOT, wait for the startup logo to appear, and turn on the 2D code reader.

If you use any procedure other than the above and the 2D code reader becomes inoperable, restart the 2D code reader.

4.2.6 System equipment (6)

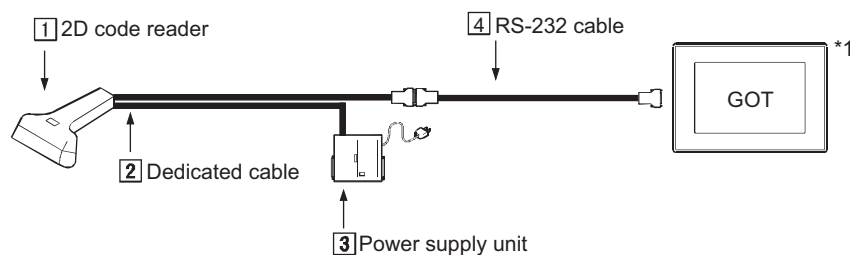

Manufacturer	1 2D code reader	2 Dedicated cable	3 Power supply unit	4 RS-232 cable
Cognex K.K.	DataMan 200	CCB-84901-1003-△△	CPS-AC-POE1A-△△	CCB-M8X4-△△

*1 When using a 2D code reader, follow one of the procedures below to turn on it.

- Turn on the GOT, wait 2 seconds or more, and turn on the 2D code reader.
- Turn on the GOT, wait for the startup logo to appear, and turn on the 2D code reader.

If you use any procedure other than the above and the 2D code reader becomes inoperable, restart the 2D code reader.

4.2.7 System equipment (7)

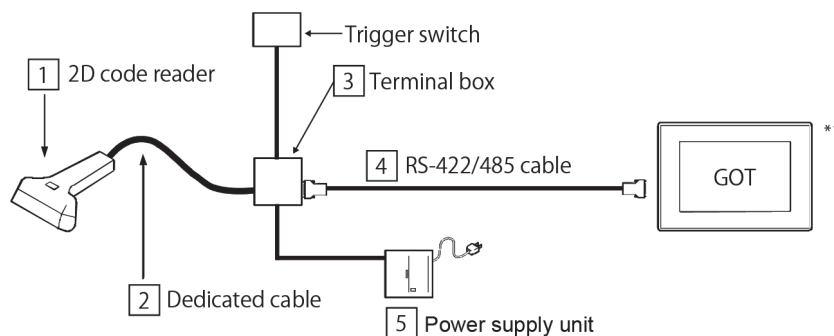

Manufacturer	1 2D code reader	2 Dedicated cable	3 Terminal box	4 RS-422/485 cable	5 Power supply unit
IDEC AUTO-ID SOLUTIONS Corporation	MATRIX210N-21□-□□□	Included with a 2D code reader	CBX100	Produced by the user Refer to 1) below.	PS5R-VB24

*1 When using a 2D code reader, follow one of the procedures below to turn on it.

- Turn on the GOT, wait 2 seconds or more, and turn on the 2D code reader.
- Turn on the GOT, wait for the startup logo to appear, and turn on the 2D code reader.

If you use any procedure other than the above and the 2D code reader becomes inoperable, restart the 2D code reader.

[Issue No.] GOT-A-0064-AD

1) RS-422/485 cable connection diagram for a 2D code reader manufactured by IDEC AUTO-ID SOLUTIONS Corporation.

a) For connection using the RS-422/485 interface of the GOT or GT15-RS4-9S

The following shows connection cables that must be produced by the user.

Maximum cable length: confirm with the 2D code reader manufacturer.

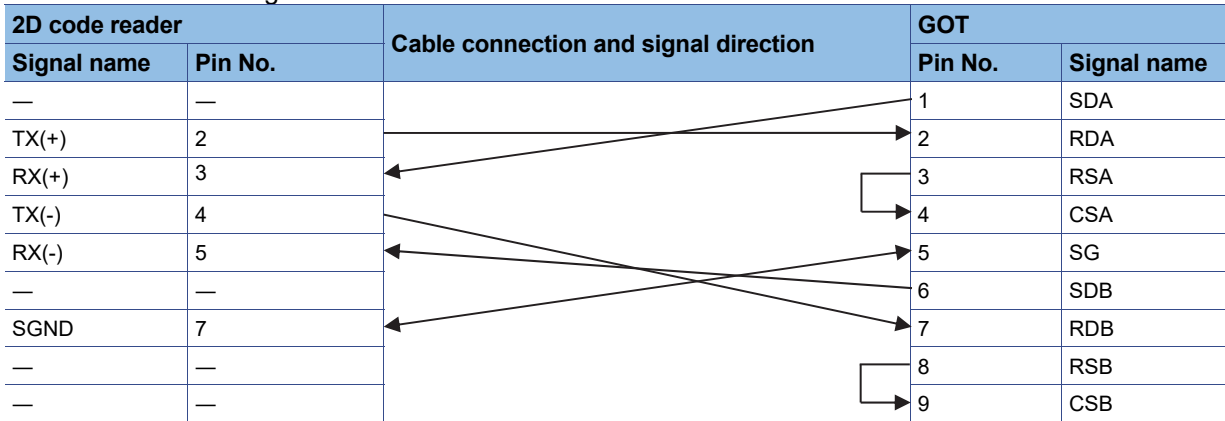

b) For connection using GT15-RS4-TE

The following shows connection cables that must be produced by the user.

Maximum cable length: confirm with the 2D code reader manufacturer.

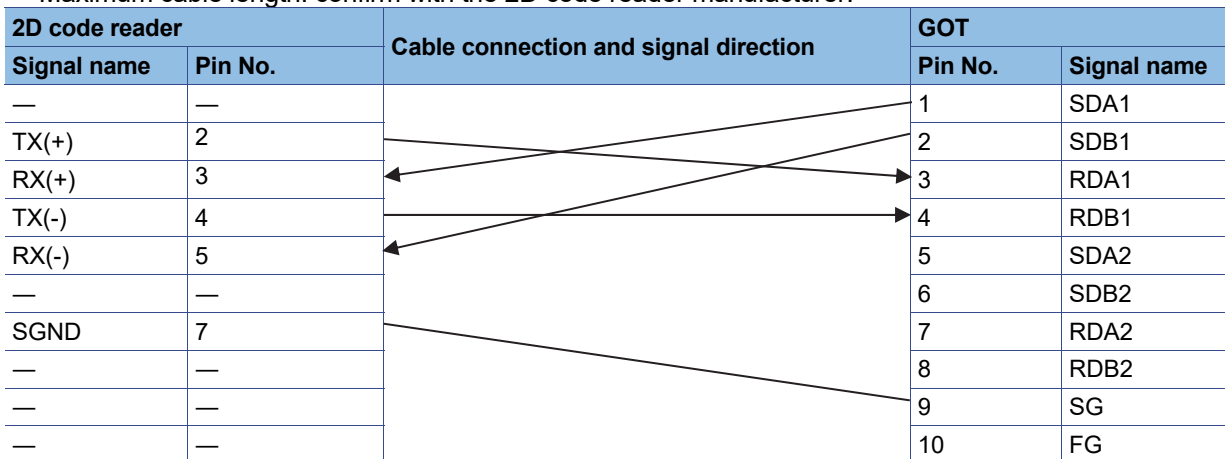

[Issue No.] GOT-A-0064-AD

4.2.8 System equipment (8)



Manufacturer	1 2D code reader	2 USB cable
IDEC AUTO-ID SOLUTIONS Corporation	QD2430-□□	·90A052065 (2 m) ·90A052095 (4 m)
	GD4430-□□	90A052065 (2 m)
	Magellan1100i-2D	Included with a barcode reader
	Magellan3200i	8-0938-01 (2 m)
	GD4590-WH	90A052065 (2 m)
	PD9531-HP	CAB-524
	GFS4470	Included with a barcode reader
DENSO WAVE INCORPORATED	AT20Q-SM	Included with a barcode reader
	AT30Q-SM	Included with a barcode reader
	AT31Q-SM	Included with a barcode reader
	GT20Q-SM	Included with a barcode reader
	SH1-QU	Included with a barcode reader
Cognex K.K.	DataMan 70S	DMA-SRTCBLELOCK-25(2.5m) DMA-SRTCBLELOCK-35(3.5m) DMA-RHTCBLELOCK-25(2.5m) DMA-RHTCBLELOCK-35(3.5m)
	DataMan 8050 *2	DM8500-USB□-□□
Zebra Technologies, Inc.	DS6707-HD	Included with a barcode reader
SICK Inc.	IDM240-100H *1	Included with a barcode reader
Honeywell International Inc.	Xenon 1900GSR-1	Included with a barcode reader
	1470g	CBL-500-200-C00
	1950g	CBL-500-300-S00
MARS TOHKEN SOLUTION CO.,LTD	THIR-6780U	Included with a barcode reader
	MCR-H200	Included with a barcode reader
KEYENCE CORPORATION	HR-100	Included with a barcode reader
OPTOELECTRONICS CO.,LTD.	L-22X-V-WHT	UF1-HSCS20S5003-A-PAC
	L-46X-OCR3.0-V-WHT	UF1-HSCG20S5003-A-PAC

*1 GT27 / GT25-W / GT2505-V are supported with CoreOS version V or later and GT 23 with CoreOS version N or later. Not supported by GT21-W.

*2 The communication module DMCM-SERIALM-00 is required.

4.2.9 System equipment (9)

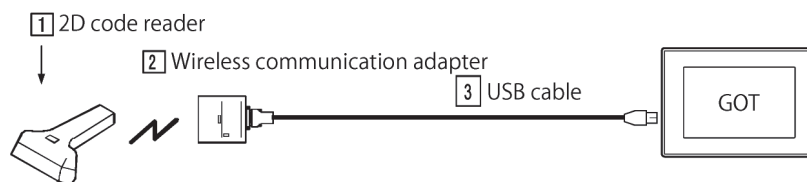

Manufacturer	1 2D code reader	2 Wireless communication adapter	3 USB cable
DENSO WAVE INCORPORATED	GT20Q-SB	BA20-RU (sold separately)	CBBA-US2000/4 (sold separately)
Cognex K.K.	DataMan 8050X *1	iBaseBT (sold separately)	28awg/1p+28awg/2c (sold separately)
IDEC AUTO-ID SOLUTIONS Corporation	PBT9500-HPRB	BC9130-BT	CAB-524
	GBT4500-WH-WLC	WLC4090-WH-BT	90A052065 (2 m) (sold separately)
Honeywell International Inc.	Xenon 1902GSR-1	CCB01-010BT	CBL-500-300-S00

*1 The communication module DMCM-WLESSM-00 is required.

[Issue No.] GOT-A-0064-AD

4.2.10 System equipment (10)

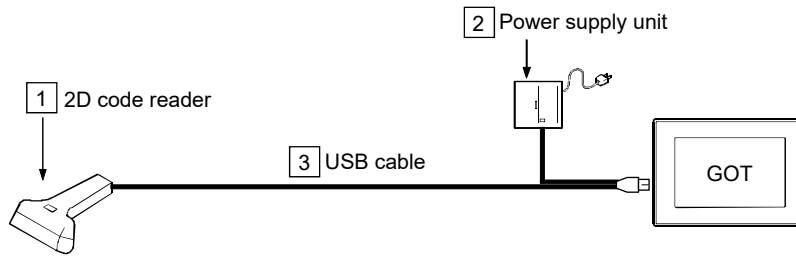

Manufacturer	1 2D code reader	2 Power supply unit	3 USB cable
Cognex K.K.	DataMan 8600 *1	GT-41076-0609-3.0	DM8500□-USB-□□
	DataMan 8072□□ *1		
	DataMan 8700DX *2	DM8700-PWR-00	DMC-HH-USBC-02

*1 The communication module DMCM-SERIALM-00 is required.

*2 The communication module DM8700-USB-Kit is required.

4.2.11 System equipment (11)

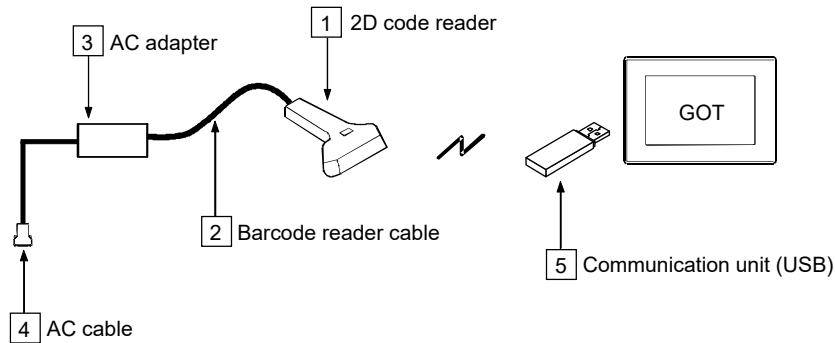

Manufacturer	1 2D code reader	2 Barcode reader cable	3 AC adapter	4 AC cable	5 Communication unit
KEYENCE CORPORATION	SR-G100	SR-PU1 (sold separately)	OP-88020 (sold separately)	OP-99012 (sold separately)	SR-UB1 (sold separately)

4.2.12 System equipment (12)

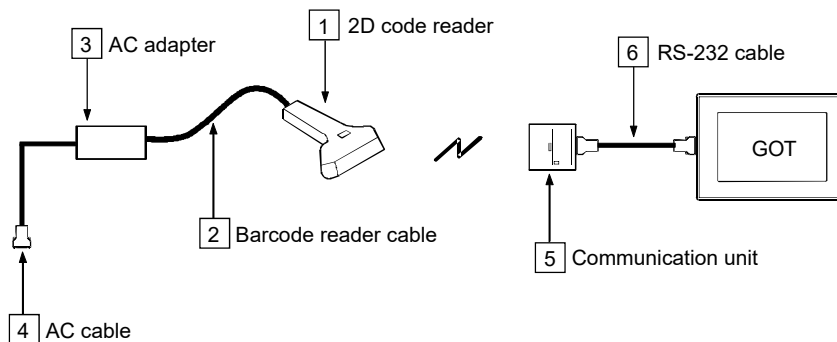

Manufacturer	1 2D code reader	2 Barcode reader cable	3 AC adapter	4 AC cable	5 Communication unit	6 RS-232 cable
KEYENCE CORPORATION	SR-G100	SR-PU1 (sold separately)	OP-88020 (sold separately)	OP-99012 (sold separately)	SR-LR1 (sold separately)	Produced by the user Refer to 1) below.

[Issue No.] GOT-A-0064-AD

1) RS-232 cable connection diagram for a 2D code reader manufactured by KEYENCE CORPORATION. The following shows connection cables that must be produced by the user.

2D code reader		Cable connection and signal direction	GOT	
Signal name	Pin No.		Pin No.	Signal name
—	1		1	—
SD(TXD)	2		2	RD(RXD)
RD(RXD)	3		3	SD(TXD)
—	4		4	—
SG	5		5	SG
—	6		6	—
—	7		7	—
—	8		8	—
—	9		9	—

4.3 Compatible 2D code type

Only “QR code” is supported by the GOT.

4.4 How to read data by a 2D code reader

Please refer to the followings for the data transfer format (header/terminator settings and others) that can be used in the GOT or the setting method to read data by a 2D code reader.

- Data transfer format (header/terminator settings and others) that can be used in the GOT.
- Setting to connect a 2D code reader to the GOT. ([Peripheral Setting] on GT Designer3(GOT2000))
- Setting to write the data, read by a 2D code reader, to the PLC CPU. ([Detail Setting] in the [Bar Code] dialog box on GT Designer3(GOT2000))
Refer to the following.
 - GT Designer3 (GOT2000) Screen Design Manual (SH-081220ENG)
- Setting the procedure from connecting a 2D code reader to the GOT until reading 2D code data.
Refer to the following.
 - GOT2000 Series Connection Manual (Microcomputers, MODBUS/Fieldbus Products, Peripherals) For GT Works3 Version1 (SH-081200ENG)

4.5 When using the GT21 model

To connect the barcode reader with the built-in RS-232 port (on the back side) of GT2103-PMBDS or GT2103-PMBDS2, use the cable GT10-C02H-6PT9P.

To use GT2104-R, refer to the following and fabricate a cable for connecting the GOT.

■User cable

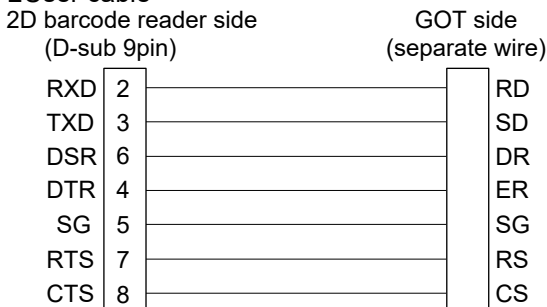

[Issue No.] GOT-A-0064-AD

5. Hubs for Ethernet Connection and Gateway Function

(Compatible Product)

Manufacturer	Model
Allied Telesis K.K.	CentreCOM FS708XL, CentreCOM MR815TL, CentreCOM RH505EL, CentreCOM FS705TX, CentreCOM FS705TX V2
I-O DATA DEVICE, INC.	ETX-ESH5, ETX-SH5
KEYENCE CORPORATION	NE-V08
PHOENIX CONTACT	FL SWITCH SF 8TX, FL SWITCH 5TX (Hardware version 13 or later)
Mitsubishi Electric Corporation	NZ2EHG-T8
Mitsubishi Cable Industries, Ltd.	ET10618, ST12904-AC
Mitsubishi Electric System & Service Co., Ltd.	DT125TX-B

(Discontinued Product *1)

Manufacturer	Model
Allied Telesis K.K.	CentreCOM MR820TR, CentreCOM 3012TR V2
Mitsubishi Cable Industries, Ltd.	ST12608

*1 Discontinued Products are not checked with GOT2000 Series.

(Incompatible Product *1)

Manufacturer	Model
BUFFALO INC.	LSW-TX-5EP

*1 Incompatible Products are not checked with GOT2000 Series.

6. Video Camera

Precautions

Some video cameras may require a separate power supply unit.

Regarding a required power supply unit for a video camera, confirm with the manufacturer.

(Compatible Product)

Manufacturer	Model
Sony Corporation	XC-ST70 *1, XC-ST50 *1, XC-ST51 *1, XC-ES50 *1, XC-ES50L *1, XC-ES51 *1, XC-ES30 *1, XC-EI50 *1, XC-EI30 *1, XC-ST70CE *2, XC-ST30CE *2, XC-ES30CE *2
TOSHIBA TELI CORPORATION	CS8630i *1, CS8550i-51 *1*3, CS8311Bi *2, CS8310Bi *1
SENSOR TECHNOLOGY CO.,LTD (SENTECH)	STC-620BJ2 *3

*1 EIA format (Monochrome) Set NTSC for the video input signal of the communication settings.

*2 CCIR format (Monochrome) Set PAL for the video input signal of the communication settings.

*3 Set the 1/60s interlace mode for the video output mode (VIDEO) of the dipswitch on the camera rear panel.

(Discontinued Product)

Manufacturer	Model
Mitsubishi Electric Corporation	CIT-9510M *1*2, CIT-8800M *1*2, CIT-8510M *1*2, CIT-8000 *1*2, C-4010 *1*2, C-2915 *1*2, C-2670 *1*2, C-2600 *1*2

*1 NTSC format (Color)

*2 Some video cameras may require a separate power supply unit or the equipment for converting the specifications to Mitsubishi Electric specifications. For details, check the manual of the video camera to be used.

7. Display

(Discontinued Product)

Manufacturer	Model
Mitsubishi Electric Corporation	RDT1713LM, RDT198LM, RDT223WLM, RDT234WLM, RDT234WX, RDT234WX-3D, RDT235WLM, RDT235WX, RDT241WEX, RDT242WH

8. Speaker

◎: Recommended product, ○: Operation validated, ×: Operation not checked

Manufacturer	Model	Operation validation
Mitsubishi Electric Engineering Co., Ltd.	FA1-GT0S04W	◎
ELECOM CO.,LTD.	MS-P06ABD, MS-130SV	○
Logicool.	Z200WH	○
SANWA SUPPLY INC.	MM-SPL6BK, MM-SPL2N2	○
Audio-Technica Corporation	AT-SP93, AT-SP121	○
TOA Corporation	A-1806 *1	○
NOBORU ELECTRIC Co., Ltd.	FA-202 *1	○

*1 This is a power amplifier.
Select a speaker according to the specifications of the power amplifier.

When power is supplied to a speaker from the USB interface (Host) of the GOT, up to 500 mA at 5V DC is available.

Some speakers may need more power depending on their specifications and use environment.
Check the specifications of the speaker prior to use.

8.1 When using the sound output unit mounted on the GOT

Use a speaker with a built-in amplifier.
Use a speaker compatible with the following specifications.

Item	Specification
Sound output terminal	For connecting external L/R speakers, 1 channel for each speaker (2 Vp-p)
Applicable jack	Φ 3.5 stereo mini jack
Playable file	<ul style="list-style-type: none"> ·When GT Designer3 Ver1.175H or earlier is used WAV format (8.000 kHz, 16 bits, mono), maximum playback time: 8 seconds ·When GT Designer3 Ver1.175H or later is used WAV format (8.000 kHz or 16.000 kHz, 16 bits, mono), maximum playback time: 30 seconds

8.2 When using the sound output interface of the GT25 wide model

Use a speaker with a built-in amplifier.
Use a speaker compatible with the following specifications.

Item	Specification
Sound output terminal	For connecting external L/R speakers, 1 channel for each speaker (2.1 Vms)
Applicable jack	Φ 3.5 stereo mini jack (3 poles)
Playable file	WAV format (8.000 kHz or 16.000 kHz, 16 bits, mono), maximum playback time: 30 seconds

9. RFID Controller

9.1 Compatible Products

9.1.1 RS-232 connection

○: Supported, ×: Not supported, -: Not validated

Manufacturer	Model	Operation validation	
		GOT2000	GT SoftGOT2000
LS ELECTRIC Co., Ltd	LSRF-C	○	○
OMRON Corporation	V600/V620	○	○
MARS TOHKEN SOLUTION CO., LTD	ICU-60S	○	○
	ICU-215	○	×
PONGEE INDUSTRIES CO., LTD	PUA-310	○	○
	PUA-310V1-0/M0R2H05	○	○
	PUA-310V1-0/M0R2H05-CH	○	○
	PUA-310V1-0/M0R2D04	○	○
HID Global Corporation	Serial ProxPro Reader 5352A	○	○

9.1.2 RS-422/485 connection

○: Supported, ×: Not supported, -: Not validated

Manufacturer	Model	Operation validation	
		GOT2000	GT SoftGOT2000
OMRON Corporation	V600	○	×
	V680	○	×
HID Global Corporation	Serial ProxPro Reader 5352A	○	×

9.2 System equipment of RFID controllers

9.2.1 When using the RS-232 connection

The following shows the equipment to configure with different types of RFID controllers.

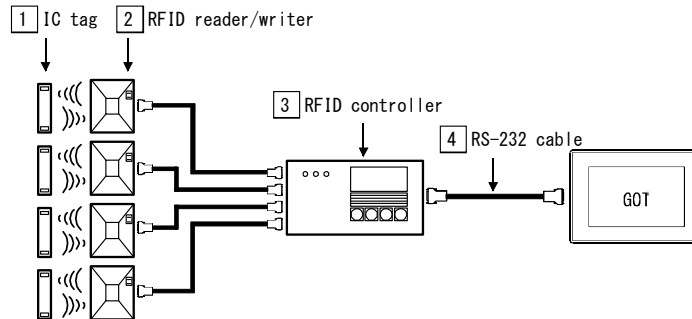

Manufacturer	1 IC tag	2 RFID reader/writer	3 RFID controller	4 RS-232 cable
LS ELECTRIC Co., Ltd	LSRT125	LSRF-L	LSRF-C	Produced by the user Refer to (1) below *1
OMRON Corporation	V600-D□	V600-H□	V600-CA5D□	Produced by the user Refer to (2) below *1
	V620-D8KR01	V620-H□	V620-CA1A	Produced by the user Refer to (3) below *1
MARS TOHKEN SOLUTION CO.LTD..	Mifare(ISO14443 TypeA) card	ICU-60S (built-in a controller)		Produced by the user Refer to (4) below *1
		ICU-215 (built-in a controller)		Produced by the user Refer to (5) below *1
PONGEE INDUSTRIES CO., LTD	PUA-310-compatible tag Mifare(ISO14443 TypeA) card	PUA-310 (built-in a controller)		Produced by the user Refer to (6) below *1
		PUA-310V1-0/M0R2H05 (built-in a controller)		
		PUA-310V1-0/M0R2H05-CH (built-in a controller) PUA-310V1-0/M0R2D04 (built-in a controller)		
HID Global Corporation	125 kHz Prox	Serial ProxPro Reader 5352A (built-in a controller)		Produced by the user Refer to (7) below *1

*1 To connect the RFID controller to GT SoftGOT2000, connect the following USB/RS-232 conversion cables to a USB port on the personal computer.

For the USB/RS-232 conversion cables, refer to Technical Bulletin FA-D-0036.

- DIFC-U2 (Diatrend Corporation)
- DAC01R2VD (Diatrend Corporation)

<Connection example>

[RFID controller (RS-232)] + [3 RS-232 cable] + [DAC01R2VD] + [DIFC-U2] + [Personal computer (USB)]

[Issue No.] GOT-A-0064-AD

(1) RS-232 cable connection diagram for an RFID controller manufactured by LS ELECTRIC Co., Ltd
 The following shows connection cables that must be produced by the user.
 Maximum cable length: confirm with the RFID controller manufacturer.

RFID controller		Cable connection and signal direction	GOT	
Signal name	Pin No.		Pin No.	Signal name
NC	1		1	CD
RD(RXD)	2	←	2	RD(RXD)
SD(TXD)	3	→	3	SD(TXD)
NC	4	←	4	DTR(ER)
SG	5	→	5	SG
NC	6	←	6	DSR(DR)
NC	7	←	7	RS(RTS)
NC	8	←	8	CS(CTS)
NC	9		9	NC

* For the cables between [2] and [3], refer to the manual created by LS ELECTRIC Co., Ltd.

(2) RS-232 cable connection diagram for a V600 RFID controller manufactured by OMRON Corporation
 The following shows connection cables that must be produced by the user.
 Maximum cable length: confirm with the RFID controller manufacturer.

RFID controller		Cable connection and signal direction	GOT	
Signal name	Pin No.		Pin No.	Signal name
—	1		1	CD
SD	2	→	2	RD(RXD)
RD	3	←	3	SD(TXD)
RS	4	←	4	DTR(ER)
CS	5	←	5	SG
—	6		6	DSR(DR)
—	7		7	RS(RTS)
—	8		8	CS(CTS)
SG	9	→	9	—

* For the cables between [2] and [3], refer to the manual created by OMRON Corporation

(3) RS-232 cable connection diagram for a V620 RFID controller manufactured by OMRON Corporation
 The following shows connection cables that must be produced by the user.
 Maximum cable length: confirm with the RFID controller manufacturer.

RFID controller		Cable connection and signal direction	GOT	
Signal name	Pin No.		Pin No.	Signal name
FG	1		1	CD
SD	2	→	2	RD(RXD)
RD	3	←	3	SD(TXD)
RS	4	←	4	DTR(ER)
CS	5	←	5	SG
—	6		6	DSR(DR)
SG	7	→	7	RS(RTS)
—	8		8	CS(CTS)
ER	20		9	NC

* For the cables between [2] and [3], refer to the manual created by OMRON Corporation

[Issue No.] GOT-A-0064-AD

(4) RS-232 cable connection diagram for an ICU-60S RFID controller manufactured by MARS TOHKEN SOLUTION CO.LTD.

The following shows connection cables that must be produced by the user.
Maximum cable length: confirm with the RFID controller manufacturer.

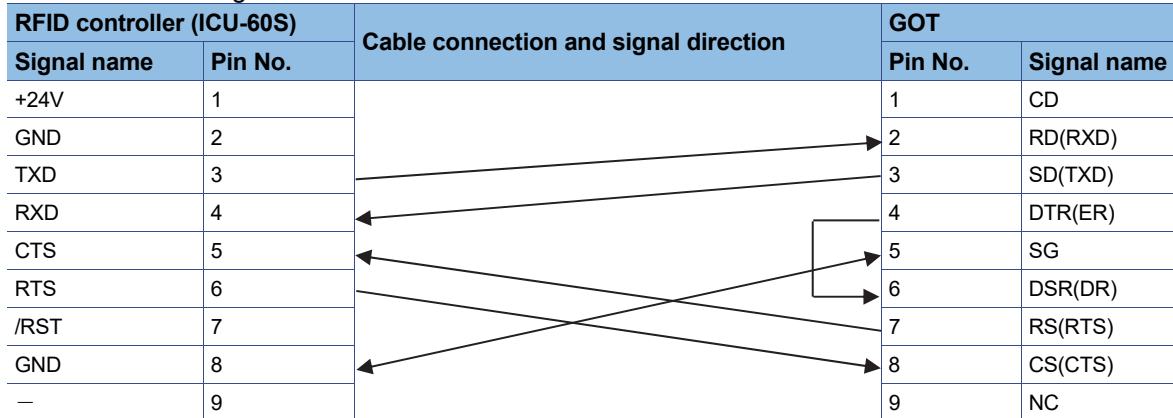

(5) RS-232 cable connection diagram for an ICU-215 RFID controller manufactured by MARS TOHKEN SOLUTION CO.LTD.

The following shows connection cables that must be produced by the user.
Maximum cable length: confirm with the RFID controller manufacturer.

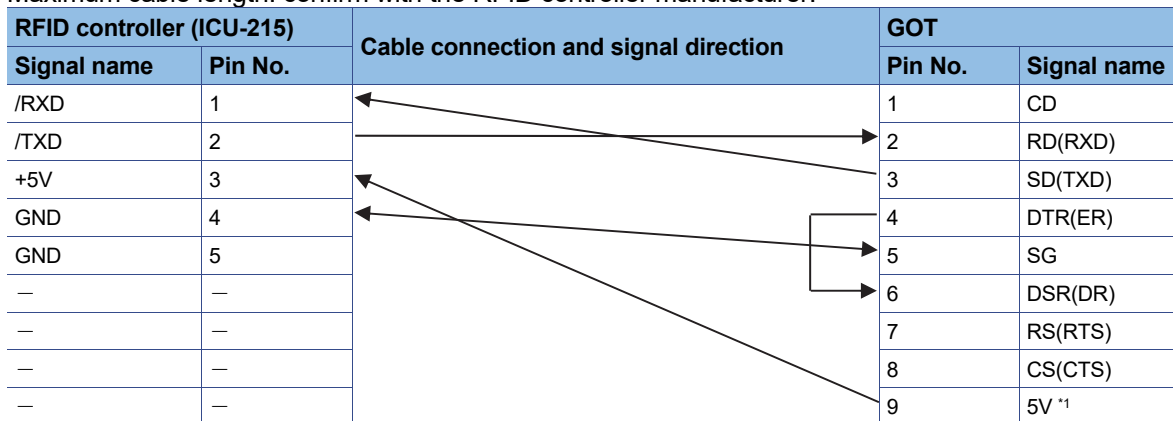

*1 Supply 5VDC to the RFID controller.

[Issue No.] GOT-A-0064-AD

(6) RS-232 cable connection diagram for an ICU-215 RFID controller manufactured by PONGEE INDUSTRIES CO., LTD.

The following shows connection cables that must be produced by the user.
Maximum cable length: confirm with the RFID controller manufacturer.

RFID controller		Cable connection and signal direction	GOT	
Signal name	Color		Pin No.	Signal name
+12VDC	Red		1	CD
Ground	Black	←	2	RD(RXD)
TX+	White	→	3	SD(TXD)
Shield/Ground	Yellow	→	4	DTR(ER)
—	—		5	SG
—	—		6	DSR(DR)
—	—		7	RS(RTS)
—	—		8	CS(CTS)
—	—		9	—

(7) RS-232 cable connection diagram for an RFID controller manufactured by HID Global Corporation
The following shows connection cables that must be produced by the user.

Maximum cable length: confirm with the RFID controller manufacturer.

RFID controller		Cable connection and signal direction	GOT	
Signal name	Pin No.		Pin No.	Signal name
DC+	1		1	CD
GROUND	2		2	RD(RXD)
SIG GND	3	←	3	SD(TXD)
TX+/485+	4	→	4	DTR(ER)
TX-/485-	5	→	5	SG
RX+/TD	6	→	6	DSR(DR)
RX-/RD	7	←	7	RS(RTS)
DTR	8	→	8	CS(CTS)
DSR	9		9	NC
TAMPER	10		-	-
TAMPER SELECT	11		-	-

DIP switch setting on the controller

Dip1		Dip2	
SW1-1	OFF	SW2-1	ON
SW1-2	OFF	SW2-2	ON
SW1-3	OFF	SW2-3	ON
SW1-4	ON	SW2-4	OFF
SW1-5	ON	SW2-5	OFF
SW1-6	OFF	SW2-6	OFF
SW1-7	OFF	SW2-7	OFF
SW1-8	OFF	SW2-8	OFF

9.2.2 When using the RS-422/485 connection

The following shows the equipment to configure with different types of RFID controllers.

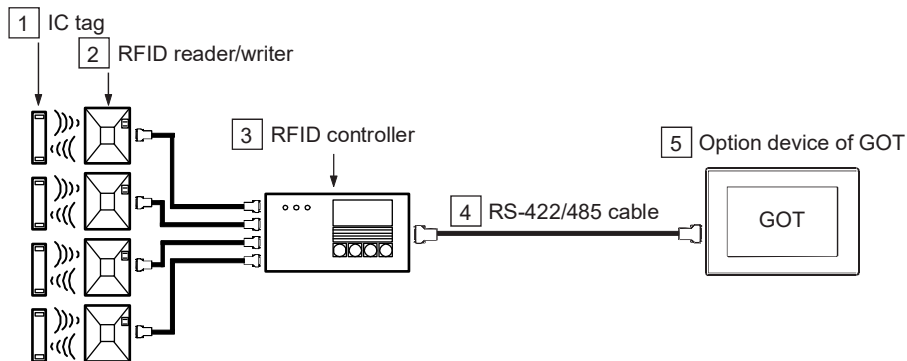

Manufacturer	1 IC tag	2 RFID reader/writer	3 RFID controller	4 RS-232 cable	5 Option device of GOT
OMRON Corporation	V600-D□	V600-H□	V600-CA5D□	Produced by the user Refer to (1) below	- (Built into GOT) GT15-RS4-9S
				Produced by the user Refer to (2) below	GT15-RS4-TE
	V680-D□	V680-H□	V680-CA5D□	Produced by the user Refer to (1) below	- (Built into GOT) GT15-RS4-9S
				Produced by the user Refer to (2) below	GT15-RS4-TE
HID Global Corporation	125 kHz Prox	Serial ProxPro Reader 5352A (built-in a controller)	Produced by the user Refer to (3) below	- (Built into GOT) GT15-RS4-9S	
			Produced by the user Refer to (4) below	GT15-RS4-TE	

(1) RS-422/485 cable (D-sub, 9 pins) connection diagram for an RFID controller (V600/V680) manufactured by OMRON Corporation

(a) For the RS-422 connection

The following shows connection cables that must be produced by the user.

Maximum cable length: confirm with the RFID controller manufacturer.

RFID controller		Cable connection and signal direction	GOT	
Signal name	Pin No.		Pin No.	Signal name
RDA(-)	1		1	SDA
RDB(+)	2		2	RDA
SDA(-)	3		3	RSA
SDB(+)	4		4	CSA
SG	5		5	SG
—	—		6	SDB
—	—		7	RDB
—	—		8	RSB
—	—		9	CSB
—	—	—	FG	

* For the cables between [2] and [3], refer to the manual created by OMRON Corporation

[Issue No.] GOT-A-0064-AD

(b) For the RS-485 connection

The following shows connection cables that must be produced by the user.

Maximum cable length: confirm with the RFID controller manufacturer.

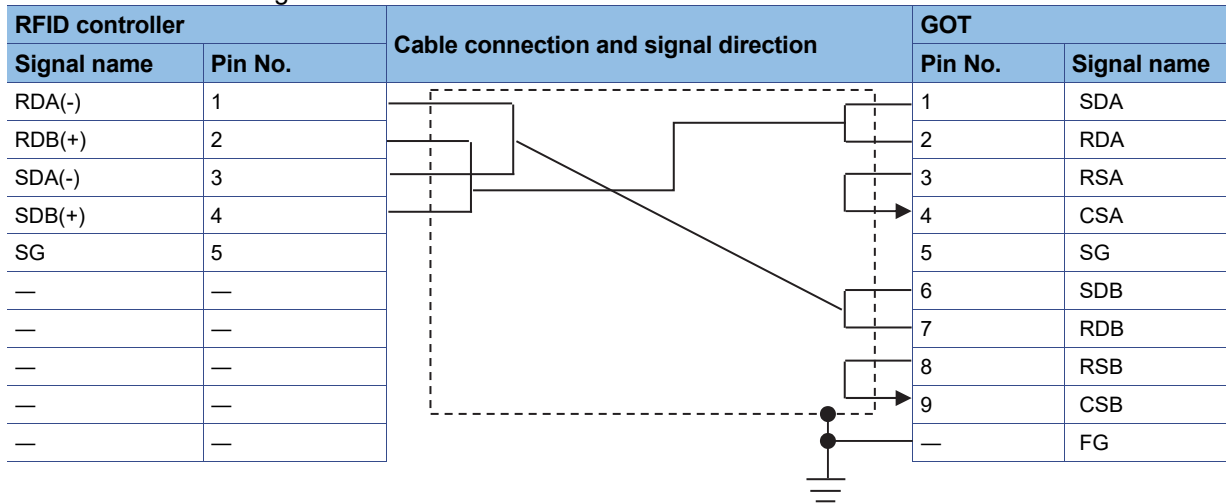

* For the cables between [2] and [3], refer to the manual created by OMRON Corporation

(2) RS-422/485 cable (terminal block) connection diagram for an RFID controller (V600/V680) manufactured by OMRON Corporation

The following shows connection cables that must be produced by the user.

Maximum cable length: confirm with the RFID controller manufacturer.

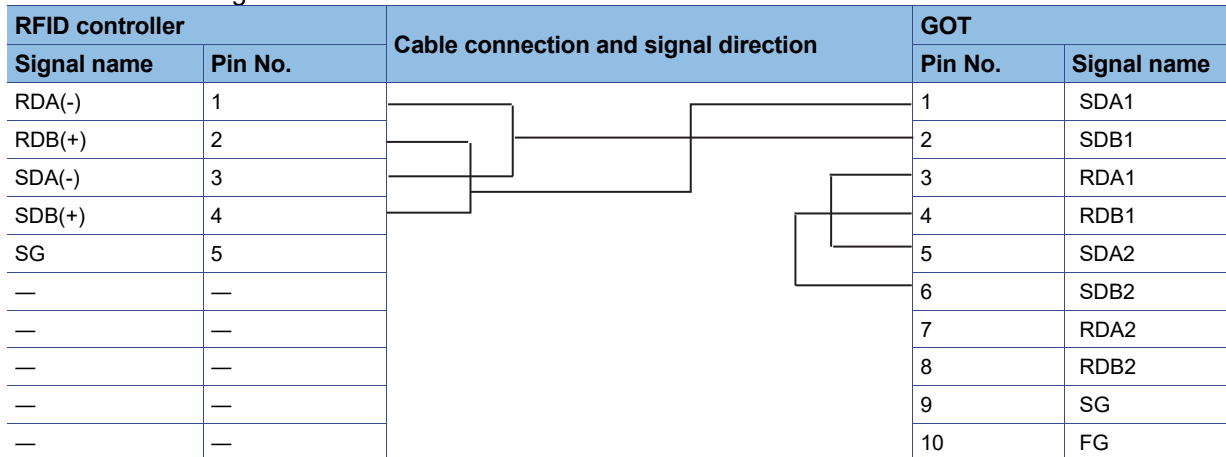

* For the cables between [2] and [3], refer to the manual created by OMRON Corporation

[Issue No.] GOT-A-0064-AD

(3) RS-422 cable (D-sub, 9 pins) connection diagram for an RFID controller manufactured by HID Global Corporation

The following shows connection cables that must be produced by the user.

Maximum cable length: confirm with the RFID controller manufacturer.

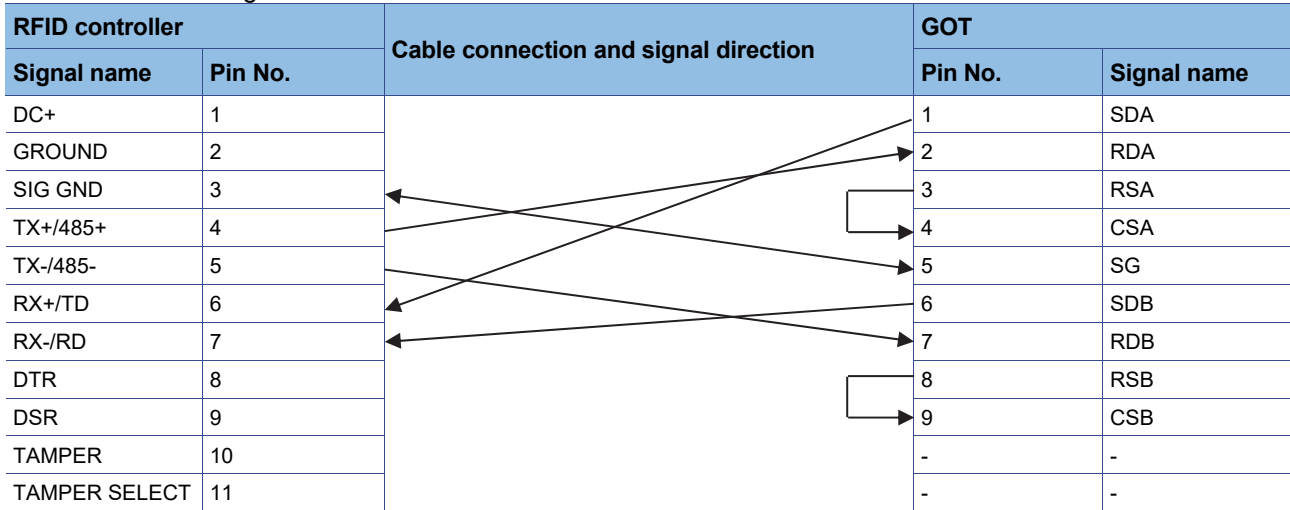

DIP switch setting on the controller

Dip1		Dip2	
SW1-1	OFF	SW2-1	ON
SW1-2	OFF	SW2-2	ON
SW1-3	OFF	SW2-3	OFF
SW1-4	ON	SW2-4	OFF
SW1-5	ON	SW2-5	OFF
SW1-6	OFF	SW2-6	OFF
SW1-7	OFF	SW2-7	OFF
SW1-8	OFF	SW2-8	OFF

[Issue No.] GOT-A-0064-AD

(4) RS-485 cable (terminal block) connection diagram for an RFID controller manufactured by HID Global Corporation

The following shows connection cables that must be produced by the user.

Maximum cable length: confirm with the RFID controller manufacturer.

RFID controller		Cable connection and signal direction	GOT	
Signal name	Pin No.		Pin No.	Signal name
DC+	1		1	SDA1
GROUND	2		2	SDB1
SIG GND	3		3	RDA1
TX+/485+	4		4	RDB1
TX-/485-	5		5	SDA2
RX+/TD	6		6	SDB2
RX-/RD	7		7	RDA2
DTR	8		8	RDB2
DSR	9		9	SG
TAMPER	10		10	FG
TAMPER SELECT	11		-	-

DIP switch setting on the controller

Dip1		Dip2	
SW1-1	OFF	SW2-1	ON
SW1-2	OFF	SW2-2	OFF
SW1-3	OFF	SW2-3	OFF
SW1-4	ON	SW2-4	OFF
SW1-5	ON	SW2-5	OFF
SW1-6	OFF	SW2-6	OFF
SW1-7	ON	SW2-7	OFF
SW1-8	ON	SW2-8	OFF

9.3 How to read data by an RFID controller

Please refer to the followings for the data transfer format (header/terminator settings and others) that can be used in the GOT or the setting method to read data by an RFID controller.

- Data transfer format (header/terminator settings and others) that can be used in the GOT.
- Setting to connect an RFID controller to the GOT. ([Peripheral Setting] on GT Designer3(GOT2000))
- Setting to write the data, read by an RFID controller, to the PLC CPU. ([Detail Setting] in the [Bar Code] dialog box on GT Designer3(GOT2000))
Refer to the following.
→ GT Designer3 (GOT2000) Screen Design Manual (SH-081220ENG)
- Setting procedure from connecting an RFID controller to the GOT until reading IC tag data.
Refer to the following.
→ GOT2000 Series Connection Manual (Microcomputers, MODBUS/Fieldbus Products, Peripherals) For GT Works3 Version1 (SH-081200ENG)
- The send data and receive data for an RFID controller manufactured by MARS TOHKEN SOLUTION CO.LTD.
 - 1) ICU-60S
Send data: Set the data except STX and ETX to LF.
Receive data: The data except STX and ETX to LF are stored.
 - 2) ICU-215
Send data: Set the data except STX and BCC to ETX.
Receive data: The data except STX and BCC to ETX are stored.

9.4 RFID Controllers Available for the External Authentication

The following RFID controllers are available for the external authentication.

Manufacturer	Model
LS ELECTRIC Co., Ltd	LSRF-C
OMRON Corporation	V600/V620
PONGEE INDUSTRIES CO., LTD	PUA-310
	PUA-310V1-0/M0R2H05
	PUA-310V1-0/M0R2H05-CH
	PUA-310V1-0/M0R2D04
HID Global Corporation	Serial ProxPro Reader 5352A

10. USB Mouse Function

Item	Specification
USB mouse	Two-button USB mouse which is compliant with USB2.0 ^{*1*2*3}

- *1 A wheeled mouse and a mouse with more than three buttons can be used as a two-button mouse.
- *2 A particular USB mouse and others may not be available depending on the USB mouse type.
Particular function examples:
A composite device (a device with a USB hub function, a card reader, a numeric keypad, or others), a 4-button mouse, and a mouse whose functions are added by dedicated driver software
- *3 The USB2.0 compliance includes forward compatibility with USB3.0 and others, as well as backward compatibility with USB1.1 and others.

11. USB Keyboard Function

11.1 USB Keyboard

Item	Specification
USB keyboard	Japanese 106 keyboard, English 101 keyboard, and forward-compatible keyboards (Japanese 109 keyboard and others), which are compliant with USB2.0 and OADG ^{*1*2*3}

- *1 Only keys compatible with Japanese 106 keyboards and English 101 keyboards are available.
(Keys other than on Japanese 106 keyboards or on an English 101 keyboards are invalid.)
- *2 A keyboard with a particular function and others may not be available depending on the keyboard type.
- *3 The USB2.0 compliance includes forward compatibility with USB3.0 and others, as well as backward compatibility with USB1.1 and others.

11.2 USB Barcode Reader

When data is input from a USB barcode reader, the GOT supports only the ASCII code characters that can be output using a USB keyboard.

The GOT ignores data that cannot be output in the ASCII code.

When connected by USB, the barcode reader can send key codes to input objects (such as text input or numerical input) by using the USB keyboard function. (The input value is processed as the ASCII code.)

To use a USB barcode reader with GT SoftGOT2000, install GT SoftGOT2000 version 1.144A or later.

For the compatible products, refer to the following.

- 3.1.3 USB connection
- 4.1.3 USB connection

11.3 USB RFID Controller

When connected by USB, the RFID controller can send key codes to input objects (such as text input or numerical input) by using the USB keyboard function. (The input value is processed as the ASCII code.)
Set the peripheral device as a UBS barcode reader to write values to the devices.

When connected by USB, the RFID controller cannot be used for the RFID function. To use the RFID function, use the device that can connect to the RS-232 or RS-422/485 interface.

○: Supported, ×: Not supported, -: Not validated

Item	Manufacturer	Model	Operation validation
			GT27, GT25, GT21-W
USB RFID Controller	Topre Corporation	TRF-100U+	○

[Issue No.] GOT-A-0064-AD

11.4 Other device

When connected by USB, the following device can send key codes to input objects (such as text input or numerical input) by using the USB keyboard function.

Set the peripheral device as a UBS barcode reader to write values to the devices.

○: Supported, ×: Not supported, -: Not validated

Item	Manufacturer	Model	Option device	Connection cable	Operation validation GT27, GT25, GT21-W
Digital caliper	Mitutoyo Corporation	CD-15AX	IT-012U	959149 (1m)	○
			IT-016U	959149 (1m)	×
			USB-ITN-C	-	×

12. USB Hub

To use a USB hub, connect the USB hub to the GOT, and then power on the GOT.

Item	Specification
USB hub	USB hub compliant with USB2.0 ^{*1} *2

*1 A particular hub and others may not be available depending on the USB hub type.

Particular function examples:

A hub with 5 or more ports, a hub with multiple hubs, and a composite device with functions other than a hub function

*2 The USB2.0 compliance includes forward compatibility with USB3.0 and others, as well as backward compatibility with USB1.1 and others.

13. USB Cable

⊙: Recommended product, ○: Operation validated, ×: Operation not checked

Item	Manufacturer	Model	Operation validation GOT2000	Remarks
USB cable	Mitsubishi Electric System & Service Co., Ltd.	GT09-C30USB-5P	⊙	· Cable length : 3m · USB-A ↔ USB Mini-B
	Mitsubishi Electric Corporation	MR-J3USBCBL3M	○	· Cable length : 3m · USB-A ↔ USB Mini-B

14. Wireless LAN Access Point

Precautions

The country in which the wireless LAN communication unit (GT25-WLAN) is usable varies depending on the hardware version of the unit.

The product with hardware version A can be used only in Japan.

The product with hardware version B or later can be used in Japan, the United States, the EU member states, Switzerland, Norway, Iceland, and Liechtenstein.

The product with hardware version D or later can be used in Japan, the United States, the EU member states, Switzerland, Norway, Iceland, Liechtenstein, China (excluding Hong Kong, Macao, and Taiwan), and South Korea.

When the wireless LAN communication unit (GT25-WLAN) operates in station mode, a wireless LAN access point is required separately.

Use a wireless LAN access point compliant with the following specifications.

Item	Specification
Wireless LAN access point	Wireless LAN access point compatible with IEEE802.11 b/g/n ^{*1} *2*3

*1 The following shows the supported security authentication method.
64bit/128bit WEP, WPA-PSK (TKIP, AES), WPA2-PSK (TKIP, AES)

*2 IEEE802.11n only supports 2.4-GHz-bandwidth.
To use IEEE802.11n communication, perform the security authentication by the WPA-PSK (AES) or WPA2-PSK (AES) method.
When you select the WEP or TKIP method, IEEE802.11n communication cannot be used.

*3 According to the GT25-WLAN specifications, the maximum data rate is 72.2 Mbps.

15. Printer

The following printers can be used with the GOT.

GOT	Available printer	Available software	Reference
GT27, GT25	PictBridge compatible printer	GT Works3 version 1.105K or later	15.1
GT27, GT25, GT21	Serial printer	GT Works3 version 1.105K or later	15.2
GT27, GT25	Ethernet printer (ESC/P-R)	GT Works3 version 1.200J or later *1	15.3
GT27, GT25, GT21	Ethernet printer (PCL5)	GT Works3 version 1.215Z or later	

*1 Install BootOS version AJ or later on the GOT.

15.1 PictBridge compatible printer

To connect a PictBridge compatible printer to the GOT, the GT15-PRN printer unit is required.

The GT15-PRN printer unit only supports the connection to PictBridge compatible printers.

Connect such a printer to the applicable USB interface of the printer unit. Serial printers are not supported.

(When using the connection cable GT09-C30USB-5P, connect its type A connector to the printer.)

To use a PictBridge compatible printer, write the package data to the GOT using the screen design software of **GT Works3 version 1.105K or later**.

Precautions

PictBridge compatible printers are available by mounting the GT15-PRN printer unit on the GOT. However, the paper size, printable area, error handling, and others differ according to the printer models. For the details, follow the printer manual.

(1) Paper size

Regardless of the paper size set on the GOT, an image on the GOT may be printed at the size set on the printer.

When the paper size of the hard copy is specified other than the A4 size, an error may occur and the hard copy cannot be printed. Set the paper size to A4.

(2) Printable area

When using the report function of the GOT, the printable area varies according to the printer.

By the printer specifications, the trimming process is performed and some specified lines may not be printed. (The trimming process adjusts image dimensions to a full printable area specified for the paper size, and does not print the unprintable areas.)

When some areas are not printed, adjust margins and lines by using the report function of the GOT in accordance with the printer specifications. (Refer to the figure below.)

Example) When the number of lines is set to 70, and the first line and 70th line are unprintable

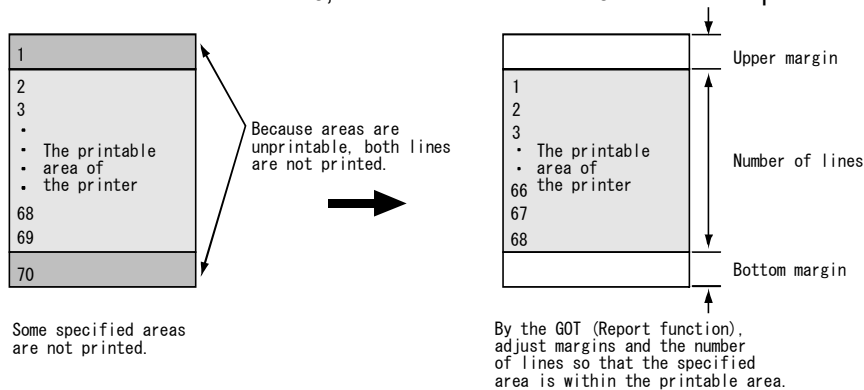

When some of lines are not printed for the report function of the GOT, configure the printer setting with no trimming. Doing so may print the lines correctly.

(3) Paper jam

For the paper jam, remove the paper, and then execute the printing process again by using the GOT.

When the printing process does not start after the above actions, execute any of the following methods.

- Press the cancel button on the printer to stop the printing process, and then execute the printing process again by using the GOT.
- Disconnect and connect the cable of the printer, and then turn on the printer again. (The printing process starts again automatically.)
- Press the OK button on the printer to stop the printing process. Then execute the printing process again by using the GOT.
- Press the cancel button on the printer. (The printing process starts again automatically.)

(4) Others

For some printers, the print enable/disable status notification signal (GS258.b3) may turn on before the preparations for printing are not completed.

Check the preparations for printing and then execute the printing process.

15.2 Serial printer

You can use a serial printer by connecting the printer to the built-in RS-232 interface, or by mounting the GT15-RS2-9P on the GOT.

To use a serial printer, write the package data to the GOT using the screen design software of **GT Works3 version 1.105K or later**.

The GOT supports printer control code ESC/P24-J84.

○: Supported, ×: Not supported, -: Not validated

Manufacturer	Model	Operation validation	Available hard copy size	Reference
		GOT2000		
NADA ELECTRONICS, LTD.	TP-642EG ^{*1}	○	QVGA, VGA ^{*2}	Refer to (1) below.
	TP-1728G ^{*1}	○	QVGA, VGA, SVGA, XGA	
SEIKO EPSON CORPORATION	VP-700U	○	QVGA, VGA, SVGA	Refer to (2) below.
	VP-D500	○	320x128dots ^{*3} , 384x128dots ^{*4} , 480x272dots ^{*5} , QVGA, VGA, WVGA, SVGA, WXGA, XGA	

*1 TP-642EG and TP-1728G only support the hard copy function.

*2 Since the hard copy size is larger than the printable size, set the printer setting to Group 6 (unprintable area not printed) or Group 5 (the hard copy printed in a reduced size).
For details on the groups of the printer setting, refer to the manual of the printer.

*3 Operation is confirmed with GT2103-P.

*4 Operation is confirmed with GT2104-P.

*5 Operation is confirmed with GT2104-R.

[Issue No.] GOT-A-0064-AD

(1) Cable connection diagram and precautions for a printer manufactured by NADA ELECTRONICS, LTD.

(a) Connection cable diagram

The following shows connection cables that must be produced by the user.

(Maximum cable length: confirm with a printer manufacturer.)

Printer		Cable connection and signal direction	GOT	
Signal name	Pin No.		Pin No.	Signal name
—	—		1	CD
RXD	2		2	RD(RXD)
TXD	3		3	SD(TXD)
—	—		4	DTR(ER)
GND	5		5	SG
—	—		6	DSR(DR)
RTS	7		7	RS(RTS)
CTS	8		8	CS(CTS)
—	—		9	NC

(b) Precautions

- Monochrome printing
- If printing is interrupted due to a turned-off printer, cable disconnection, and others, turn off and then on the printer power, and perform the printing again.
- For printing with the report function, one-byte characters are printed as two-byte characters.
- For printing with the report function, the left margin setting of the print format is disabled.
- Since the printing paper is roll paper, the page break function is disabled.

(2) Cable connection diagram and precautions for a printer manufactured by SEIKO EPSON CORPORATION

(a) Connection cable diagram

The following shows connection cables that must be produced by the user.

(Maximum cable length: confirm with a printer manufacturer.)

Printer		Cable connection and signal direction	GOT	
Signal name	Pin No.		Pin No.	Signal name
—	—		1	CD
TXD	2		2	RD(RXD)
RXD	3		3	SD(TXD)
—	—		4	DTR(ER)
SIGNAL GND	7		5	SG
—	—		6	DSR(DR)
—	—		7	RS(RTS)
DTR	20		8	CS(CTS)
—	—		9	NC

(b) Precautions

- Monochrome printing
- If printing is interrupted due to a turned-off printer, cable disconnection, and others, turn off and then on the printer power, and perform the printing again.
- For printing with the report function, the available left margin setting of the print format ranges from 0 to 67.

[Issue No.] GOT-A-0064-AD

15.3 Ethernet printer

Connect the printer to Ethernet through the built-in Ethernet interface, GT25-J71E71-100, or wireless LAN communication unit (GT25-WLAN).

The following Ethernet printers are supported.

- ESC/P-R *1
- PCL5

*1 Not available to GT21.

The following lists the models that have been validated by Mitsubishi Electric.

15.3.1 ESC/P-R

○: Supported, ×: Not supported, -: Not validated

Manufacturer	Model	Operation validation GOT2000
SEIKO EPSON CORPORATION *1	LX-10000F	○
	PX-M7070FX	○
	PX-M840FX	○
	PX-S860	○
	PX-M5041F	○
	PX-M7050FP	○
	PX-M7110F	○
	PX-M781F	○
	EW-M770T	○
	EW-M5071FT	○
	EP-306	○
	PX-M6711FT	○

- *1 Only the models that can print JPEG documents are supported.
It is confirmed that the following models do not support printing JPEG documents.
- PX-S5080
 - PX-S5040
 - PX-1004
 - PX-M650F
 - PX-S884
 - PX-S740
 - PX-105
 - EW-M670FT
 - EW-M571T
 - GP-730
 - GP-710
 - PX-M160T
 - PX-S350
 - PX-K150
 - PX-S160T

[Issue No.] GOT-A-0064-AD

15.3.2 PCL5 *1

○: Supported, ×: Not supported, -: Not validated

Manufacturer	Model	Operation validation
		GOT2000
HP Inc.	HP OfficeJet Pro 8210	○
	HP LaserJet Pro Color CP5225dn	○
	HP LaserJet Enterprise M506dn *2	○
	HP LaserJet Pro M203dn	○

*1 Only grayscale printing is supported.

*2 When the report function is used on GT21 models, Japanese and Chinese characters are printable.

(1) Paper size

Specify the same size on the GOT as the sheet size in the printer.

For the paper size specified on the GOT, refer to the following.

- When using the report function, set it in the [Report Setting] dialog.
- When using a hard copy, set it in the [Hard Copy] dialog.

For the setting details, refer to the following manual.

→ GT Designer3 (GOT2000) Screen Design Manual (SH081220ENG)

When the specified print size and the sheet size in the printer are different, an error appears on the printer or printing cannot be performed correctly.

(2) Printable area

For the printable area, refer to the following.

→ PictBridge compatible printer (2) Printable area

[Issue No.] GOT-A-0064-AD

(3) Troubleshooting

The latest error number occurred in the printer is notified by Ethernet Printer Error Info (GS259) of the GOT special registers.

The following shows the error details and corrective actions (troubleshooting) for each error number.

Error code *1	Error contents *2	Troubleshoot
1	Printer error	Check that there is no jammed paper in the printer. Then turn the power off and on again. For details, see the message on the printer's LCD screen or your documentation.
2	Fatal error	Check that there is no jammed paper in the printer. Then turn the power off and on again. For details, see the message on the printer's LCD screen or your documentation.
3	Interface not selected	Please wait.
4	Cover open	Close the printer cover.
5	Paper jam	Remove any remaining jammed paper by hand.
6	No ink	Epson recommends the use of genuine Epson ink/toner cartridges.
7	No paper	Reload the paper correctly and press the paper button (or maintenance button) on the printer.
8	<ul style="list-style-type: none"> • Paper size or paper type or paper path error • At the time of duplex printing, the specified paper size is different from the paper size actually prepared for the paper feeding device When printing is continued with this error, the print data of the next page is discarded regarded as the back side on the printer side	Change the settings to match them and start printing.
9	Waste ink overflow	Contact a distributor or repair service center of the printer manufacturer.
10	Paper double feeding error	A page has not been printed, multiple pages have been fed into the printer at once, or the wrong paper size has been fed into the printer. Remove and reload the paper. Press the Start button if necessary.
11	Ink cover open error	If you are replacing ink cartridge, close the ink cover when you have finished replacement.
12	No paper tray error	Install the cassette tray, then press the Start button on the printer.
14	Cartridge built-in waste liquid tank overflow	The printer's ink pads are at the end of their service life. Please contact Epson support.
15	Battery error (voltage abnormality)	See documentation for details.
16	Battery error (temperature abnormality)	Turn off the printer immediately and contact your dealer.
17	Battery empty	Charge the battery.
18	Photopack warranty number reached	Epson recommends the use of genuine Epson ink cartridges.
19	Initial filling failure error	Epson recommends the use of genuine Epson ink cartridges.
20	PhotPack Ink consumption 100%	Epson recommends the use of genuine Epson ink cartridges.
21	Scanner open error	Close the scanner unit.
22	CDR guide open error	Close the CD/DVD guide.
25	In the manual feed tray printing, the tray is closed	Load the single paper in the rear manual feed. See the documentation for details.

Error code *1	Error contents *2	Troubleshoot
28	Manual preparation ready	See the LCD screen on the product and follow the instructions.
29	Manual preparation ready	<ol style="list-style-type: none"> Open the paper support. Load a single sheet of paper, printable side up, short edge first. Adjust the edge guides. Insert the paper until the leading edge is approximately 5 cm (2 inch) from the notches on the edge guides. Press Load button on the printer.
30	Manual feed error	See the LCD screen on the product and follow the instructions.
31	Manual feed error	<ol style="list-style-type: none"> Remove the ejected paper. Load a single sheet of paper, printable side up, short edge first. Adjust the edge guides. Insert the paper until the leading edge is approximately 5 cm (2 inch) from the notches on the edge guides. Press Load button on the printer.
32	Manual feed too much error	See the LCD screen on the product and follow the instructions.
33	Manual feed too much error	<ol style="list-style-type: none"> Load a single sheet of paper, printable side up, short edge first. Adjust the edge guides. Insert the paper until the leading edge is approximately 5 cm (2 inch) from the notches on the edge guides. Press Load button on the printer.
36	Ink remaining amount warning	See the LCD screen on the product and follow the instructions.
37	Lack of remaining roll paper	See the LCD screen on the product and follow the instructions.
38	Battery low	Connect the AC adapter.
39	Battery low level	See documentation for details.
40	Charging	Please wait. Connect the AC adapter to continue.
41	Battery abnormally hot	Functions are limited because the battery is too hot. Connect the AC adapter.
42	Battery abnormally low temperature	Cannot use the printer because the battery is too cold. Connect the AC adapter.
47	Maintenance box replacement required	Replace the maintenance box.
48	Maintenance box not installed	Install the maintenance box correctly.
100	<ul style="list-style-type: none"> Printing is in progress from another interface or memory card When the printer continues printing operation even after printing is interrupted / terminated 	Please wait.
101	When the ink cartridge is not set in the factory shipment state	Epson recommends the use of genuine Epson ink cartridges.
102	Communication with printer failed	Check the printer cable connection and make sure the printer is on. If you are using a battery, it may be empty. Connect the AC adapter to the printer and plug it in. If the power was turned off during printing, cancel the print job. If the error does not clear, see your printer documentation.
103	Ink cartridge is not set	Epson recommends the use of genuine Epson ink cartridges.
104	The ink cartridge can not be recognized	Epson recommends the use of genuine Epson ink cartridges.

[Issue No.] GOT-A-0064-AD

Error code *1	Error contents *2	Troubleshoot
106	CDR Guide Close Error	Load the CD/DVD tray into the front tray, then resume printing.
200	Common error	See the LCD screen on the product and follow the instructions.
1015	Unsupported Printer	Please check the model of the connected printer.
1016	Paper size / color mode not supported	Check the paper size and the number of colors (color / monochrome) settings.
1100	Communication error during printer search	Check the IP address of the printer. Check the connection path with the printer.
1300	Printer not found	Check the IP address of the printer. Check the connection path with the printer.
1306	Unsupported Printer	Please check the model of the connected printer.
1407	Unsupported Printer	Please check the model of the connected printer.

*1 When connected to a printer (PCL5), only error code 1300 appears on the GOT.
If an error occurs, check the error notification on the printer.

*2 For the details of errors, refer to the manual of the printer used.

16. Media converter

(Compatible Product)

Manufacturer	Model
Mitsubishi Electric System & Service Co., Ltd.	DMC-1000TS-DC

REVISIONS

Version	Print Date	Revision
-	September 2013	- First edition (Japanese only) (Print date indicates the date that the Japanese version was issued.)
A	January 2014	- Models have been added to "3. Barcode Reader". - "13. Wireless LAN Access Point" has been added. - "14. Printer" has been added.
B	December 2014	- Models have been added to "4. 2D Code Reader".
C	February 2015	- Models have been added to "3. Barcode Reader". - Models have been added to "9. RFID Controller". - Models have been added to "11. USB Keyboard Function".
D	July 2015	- Precautions have been added to "3. Barcode Reader" and "4. 2D Code Reader".
E	-	-
F	November 2015	- A model has been added to "11.2 USB Barcode Reader". - Validated models applicable to GT SoftGOT2000 have been added to "11.2 USB Barcode Reader". - Descriptions in "13. Wireless LAN Access Point" have been revised.
G	May 2016	- A model has been added to "9. RFID Controller". - A model has been added to "11.2 USB Barcode Reader".
H	-	-
I	June 2016	- "13. USB Cable" has been added.
J	February 2017	- A model has been added to "4. 2D Code Reader". - A model has been added to "11.2 USB Barcode Reader".
K	May 2017	- A model has been added to "3. Barcode Reader". - A model has been added to "4. 2D Code Reader". - The specifications described in "8. Speaker" have been changed. - A model has been added to "8. Speaker". - Descriptions in "11.2 USB Barcode Reader" have been revised.
L	January 2018	- A model has been added to "4. 2D Code Reader". - A model has been added to "9. RFID Controller".
M	May 2018	- A model and Precautions have been added to "4. 2D Code Reader".
N	August 2018	- A model and Precautions have been added to "4. 2D Code Reader". - A model has been added to "9. RFID Controller". - A model has been added to "15.2 Serial printer". - "15.3 Ethernet printer" has been added.
O	November 2018	- A model has been added to "9. RFID Controller".
P	February 2019	- A model has been added to "3. Barcode Reader" and "4. 2D Code Reader". - A model has been added to "5. Hubs for Ethernet Connection and Gateway Function". - "16 Media converter" has been added.
Q	April 2019	- Models have been added to "3. Barcode Reader" and "15.3 Ethernet printer".
R	November 2019	- Models have been added to "4. 2D Code Reader" and "15.3 Ethernet printer".
S	March 2020	- A model has been added to "4. 2D Code Reader". - GT21-W has been added to the operation validated models in "11.3 USB RFID Controller" and "11.4 Other device".
T	April 2020	- A model has been added to "8. Speaker".
U	May 2020	- Descriptions have been added to "3. Barcode Reader" and "15.3 Ethernet printer". - Descriptions have been added to "4. 2D Code Reader" and "15.2 Serial printer".
V	July 2020	- A model has been added to "3. Barcode Reader" and "4. 2D Code Reader".

[Issue No.] GOT-A-0064-AD

Version	Print Date	Revision
W	September 2020	- Corrected clerical errors
X	November 2020	- A model has been added to "4. 2D Code Reader".
Y	January 2021	- A model has been added to "11.4 Other device".
Z	July 2021	- Corrected clerical errors
AA	September 2021	- Models have been added to "4. 2D Code Reader" and "15.3 Ethernet printer". - Hardware versions and dates of manufacturer of the models that support DataMan8050 have been added.
AB	July 2022	- A model has been added to "4. 2D Code Reader".
AC	January 2023	- A model has been added to "4. 2D Code Reader".
AD	June 2023	- LS Industrial Systems Co., Ltd. has been renamed LS ELECTRIC Co., Ltd.

Intellectual Property Rights**■ Trademarks**

QR Code is a trademark or registered trademark of DENSO WAVE INCORPORATED in Japan, the United States, and/or other countries.

Other company and product names herein are trademarks or registered trademarks of their respective owners.