

[Issue No.] GOT-A-0125-F

[Title] Precautions when Replacing the GT14 Model with GT2505(HS)-VTBD

[Date of Issue] February 2018 (Ver. F: July 2021)

[Relevant Models] GOT1000 Series (GT14 Models) → GOT2000 Series (GT2505(HS)-VTBD)

Thank you for your continued support of Mitsubishi Electric Graphic Operation Terminal (GOT).

We released GT2505-VTBD of the GOT2000 series with high functionality and performance as an alternative of the GT14 model in August 2017, and GT2505HS-VTBD in May 2018.

We highly recommend that you replace the GT14 model with GT2505(HS)-VTBD for using new sophisticated features.

Contents

1. Requests for customers.....	2
2. Replacement models.....	2
2.1 GOT.....	2
2.2 Communication unit.....	2
2.3 Option.....	3
2.4 Cable.....	3
2.4.1 RS-232 cable.....	3
2.4.2 RS-422 cable.....	3
2.4.3 Other cables.....	3
2.5 Software.....	4
2.6 License.....	4
3. Comparison in specifications.....	5
3.1 Comparison in hardware specifications.....	5
3.1.1 Performance comparison between the GT145□-Q□BD□ model and GT2505-VTBD.....	5
3.1.2 Comparison in power supply specifications between the GT145□-Q□BD□ model and GT2505-VTBD.....	7
3.1.3 Performance comparison between the GT145□HS-Q□BDE model and GT2505HS-VTBD.....	8
3.1.4 Comparison in power supply specifications between the GT145□HS-Q□BDE model and GT2505HS-VTBD.....	10
3.2 External dimension comparison.....	11
3.3 Panel cutting dimension comparison.....	13
3.4 Mounting intervals.....	14
3.5 Function specifications.....	15
3.5.1 Comparison in functions.....	15
3.5.2 Detailed comparison in functions.....	16
3.6 Screen design software specifications.....	23
3.6.1 Preparation before converting the project data.....	23
3.6.2 Procedure for the project data conversion.....	23
3.6.3 Screen design functions that are not supported.....	25
3.6.4 Other major changes.....	25
REVISIONS.....	29

[Issue No.] GOT-A-0125-F

1. Requests for customers

We released GT2505-VTBD of the GOT2000 series with high functionality and performance as an alternative of the GT14 model in August 2017, and GT2505HS-VTBD in May 2018.

We highly recommend that you replace the GT14 model with GT2505(HS)-VTBD for using new sophisticated features.

For the replacement models, refer to the following.

- 2. Replacement models

2. Replacement models

Other models can be selected depending on the usage status in your system. Select an appropriate model after carefully considering the range of performance in the current system.

For the GT2505(HS)-VTBD specifications, refer to the following.

- GOT2000 Series User's Manual (Hardware) (SH-081194ENG)

2.1 GOT

Table 2-1 Replacement GOT models of GT2505 from GT145□

○: Compatible, ×: Incompatible

GOT1000 series in use	Recommended GOT2000 series for replacement	Panel cut compatibility	Attachment necessity	Cable compatibility	Conversion cable necessity
GT1455-QTBD	GT2505-VTBD	○	Unnecessary	○	Unnecessary
GT1455-QTBDE					
GT1450-QMBD					
GT1450-QMBDE					
GT1450-QLBD					
GT1450-QLBDE					
GT1455HS-QTBDE	GT2505HS-VTBD	-	Unnecessary	○	Unnecessary
GT1450HS-QMBDE					

2.2 Communication unit

The communication units of the GOT1000 series can be used together with the GOT2000 series as-is.

Check the availability of use in the following table.

Table 2-2 List of replacement models for communication units

○: Available as-is ×: Replaceable

Unit for the GOT1000 series		Availability of use	Remarks
Product name	Model name		
Serial multi-drop	GT01-RS4-M	○	-
Connector conversion adapter	GT10-9PT5S	○	-
RS-232/485 signal conversion adapter	GT14-RS2T4-9P	○	The available connection type differs. For the available connection types, refer to the following. →GOT2000 series connection manual for the device to be connected.
CC-Link Interface unit	GT11HS-CCL	○	-
	GT11H-CCL		

[Issue No.] GOT-A-0125-F

2.3 Option

For options, use the products for the GOT2000 series.
Some options can be used as-is.
Check the availability of use in the following table.

Table 2-3 List for option replacement

○: Available as-is ×: Not available

Product name	Availability of use	Remarks
Protective sheet	×	Products for the GOT1000 series cannot be used. Use the product for the GOT2000 series. (Model: GT25-05PSGC-2, GT25-05PSCC-2) * Because the design of the front face panel and the position of the USB port differ.
Protective sheet (for the Handy GOT)	○	The product for the GOT1000 series can be used as-is.
USB environmental protection cover	×	Products for the GOT1000 series cannot be used. Use the product for the GOT2000 series. (Model: GT21-WUCOV)
Protective cover for oil	×	Products for the GOT1000 series cannot be used. Use the product for the GOT2000 series. (Model: GT25-05PCO-2)
Stand	○	The product for the GOT1000 series can be used as-is.
Memory card (SD card)	○	The product for the GOT1000 series can be used as-is.
Attachment	○	Can be used as-is if an attachment is used for the GOT1000 series. * At the replacement of the GOT1000 series with the GOT2000 series, no attachment is necessary because of the same panel cutting dimensions.
Battery (spare)	○	The product for the GOT1000 series can be used as-is. *GT2505-VTBD has a built-in battery at factory default.
Emergency stop sw guard cover	○	The product for the GOT1000 series can be used as-is.
Wall-mounting attachment	○	The product for the GOT1000 series can be used as-is.

2.4 Cable

2.4.1 RS-232 cable

The currently used cable for the GOT1000 series can be used as-is for the GOT2000 series.

2.4.2 RS-422 cable

The currently used cable for the GOT1000 series can be used as-is for the GOT2000 series.

2.4.3 Other cables

The currently used cable for the GOT1000 series can be used as-is for the GOT2000 series.

[Issue No.] GOT-A-0125-F

2.5 Software

To create project data, MELSOFT GT Designer3 (GOT2000) is needed.
 The supported version of MELSOFT GT Designer3 (GOT2000) differs depending on the model.
 For how to obtain the software in a specific version, refer to the following table.

Software	Supported version	How to obtain the software
Screen design software MELSOFT GT Works3	■Japanese/English/Chinese version When creating project data for GT2505-VTBD: MELSOFT GT Designer3 (GOT2000) that is enclosed with MELSOFT GT Works3 Version1.180N or later. When creating project data for GT2505HS-VTBD: MELSOFT GT Designer3 (GOT2000) that is enclosed with MELSOFT GT Works3 Version1.195D or later.	The version shown on the left is supported. If your version is old, update the software to the latest version. For how to obtain the software, contact your local sales office.
FA integrated engineering software MELSOFT iQ Works	■Japanese/English version When creating project data for GT2505-VTBD: Ver.2.48Q or later is supported. *1 When creating project data for GT2505HS-VTBD: Ver.2.50C or later is supported. *2	

*1 When using the interaction function of MELSOFT Navigator and MELSOFT GT Works3, update the software in MELSOFT GT Works3 (Version 1.185T or later).

*2 When using the interaction function of MELSOFT Navigator and MELSOFT GT Works3, update the software in MELSOFT GT Works3 (Version 1.197F or later).

2.6 License

The GOT1000 series licenses below cannot be used for the GOT2000 series.
 Please purchase the GOT2000 series licenses.

Table 2-4 List of replacement models for license

○: Available as-is ×: Not available

License name (license key for GOT1000)	Availability of use (license key for GOT2000)	Remarks
License of the VNC server function (GT14-VNCSKEY)	× (GT25-VNCSKEY-□)	Use the license for GOT2000.

* For how to authenticate the license, refer to the following.
 → GOT2000 Series User's Manual (Utility) (SH-081195ENG)

3. Comparison in specifications

3.1 Comparison in hardware specifications

3.1.1 Performance comparison between the GT145□-Q□BD□ model and GT2505-VTBD

For cells filled in grey, the specifications remain even after replacement.

Table 3-1 Comparison in performance specifications

Item		Model in use		Recommended model for replacement
		GT1455-QTBD(E)	GT1450-QMBD(E)	GT2505-VTBD
Conforming standards		CE(EMC), UL/cUL, KC		←
Display section	Type	TFT color liquid crystal	TFT monochrome (white/black) liquid crystal	TFT color liquid crystal
	Screen size	5.7"		←
	Resolution	QVGA : 320 x 240[dots]		VGA : 640 x 480[dots]
	Display size	W115(4.53) x H86(3.39)[mm](inch)		←
	Display character	16-dot standard font: 20 characters x 15 lines 12-dot standard font: 26 characters x 20 lines		16-dot standard font: 40 characters x 30 lines 12-dot standard font: 53 characters x 40 lines
	Display color	65536 colors	Monochrome (white/black), 16 scales	65536 colors
	Intensity adjustment	8-level adjustment		32-level adjustment
Backlight	Model	LED type (irreplaceable)		←
	Function	Backlight off/screen saving time can be set.		←
	Life	Approx. 70,000h or longer. (Time for display intensity reaches 50% at operating ambient temperature of 25 °C)		Approx. 60,000h or longer. (Time for display intensity reaches 50% at operating ambient temperature of 25 °C)
Touch panel	Type	Analog resistive film		←
	Key size	Minimum 2 x 2 dots (per key)		←
	Number of points touched simultaneously	Simultaneous presses not allowed.		←
	Life	1 million times (operating force 0.98N max.)		←
Memory	User memory	Built-in flash memory, 9Mbytes Life (Number of write times): 100,000 times		Memory for storage (ROM): 32MB Memory for operation (RAM): 80MB Life (Number of write times): 100,000 times
	Built-in SRAM	Drive D: 512KB		SRAM user area: 500KB
Battery	Model	GT11-50BAT lithium battery		←
	Life	Approx. 5 years (Operating ambient temperature of 25 °C)		←

[Issue No.] GOT-A-0125-F

Item			Model in use		Recommended model for replacement
			GT1455-QTBD(E)	GT1450-QMBD(E)	GT2505-VTBD
Built-in interface	RS-422	Specifications	1 channel, Connector shape: D-sub 9-pin (female)		←
	RS-232	Specifications	1 channel, Connector shape: D-sub 9-pin (male)		←
	Ethernet		GT1455-QTBDE, GT1450-QMBDE only 1 channel Data transfer method: 100BASE-TX, 10BASE-T, Connector shape: RJ-45 (modular jack)		1 channel Data transfer method: 100BASE-TX, 10BASE-T, Connector shape: RJ-45 (modular jack)
	USB (host)		1 channels, Maximum transfer rate: Full Speed 12Mbps Connector shape: USB-A (rear face)		1 channels, Maximum transfer rate: High-Speed 480 Mbps Connector shape: USB-A (rear face)
	USB (device)		1 channels, Maximum transfer rate: Full Speed 12Mbps Connector shape: Mini-B (front face)		1 channels, Maximum transfer rate: High-Speed 480 Mbps Connector shape: USB Mini-B (front face)
SD card		1 channel, SDHC compliant (maximum 32 GB)		←	
Buzzer output			Single tone (tone length adjustable)		Single tone (tone and tone length adjustable)
POWER LED			2 colors (green and orange)		2 colors (blue and orange)
Protective structure			I IP67f (front section of the panel only)		←
External dimensions			164(6.46)(W) × H135(5.32)(H) × 55(2.17) (D) mm(inch)		164(6.46)(W) × 139(5.47)(H) × 53.5(2.11)(D) mm(inch)
Panel cutting dimension			153(6.02)(W) × 121(4.76) (H) mm(inch)		←
Weight (Excluding mounting fixtures)			Approx. 0.7kg		Approx. 0.6kg
Compatible software package			GT Designer3 Version1.34L or later	GT Designer3 Version1.118Y or later	GT Designer3 Version1.180N or later
Installing procedure			Vertical or Horizontal		←
Control Panel Inside Dimensions for Mounting GOT			Refer to the following. → 3.4 Installing the GOT		Refer to the following. → 3.4 Installing the GOT
Mounting Position					

[Issue No.] GOT-A-0125-F

3.1.2 Comparison in power supply specifications between the GT145□-Q□BD□ model and GT2505-VTBD

For cells filled in grey, the specifications remain even after replacement.

Table 3-2 Comparison in power supply specifications

Item	Model in use		Recommended model for replacement
	GT1455-QTBD, GT1450-QMBD	GT1455-QTBDE, GT1450-QMBDE	GT2505-VTBD
Input power supply voltage	24VDC (+10% -15%), ripple voltage 200mV or less		←
Power consumption (Under the maximum load)	7.68W(320mA/24V)	8.40W(350mA/24V)	8.40 W or less
Inrush current	30 A or less (2 ms, operating ambient temperature 25 °C, maximum load)		42 A or less (2 ms, operating ambient temperature 25 °C, maximum load)
Permissible instantaneous power failure time	5 ms or less		10 ms or less
Noise immunity	1000 Vp-p noise voltage, 1s noise width (when measuring with a noise simulator under 30 to 100 Hz noise frequency)		←
Withstand voltage	500 V AC for 1 minute across power terminals and earth		←
Insulation resistance	500 V DC across power terminals and earth, 10 MΩ or more by an insulation resistance tester		←
Applicable wire size	0.75[mm ²] or more for power supply, 2[mm ²] or more for grounding		←
Applicable solderless terminal	Solderless terminal for M3 screw RAV1.25-3, V2-N3A, FV2-N3A		←

[Issue No.] GOT-A-0125-F

3.1.3 Performance comparison between the GT145□HS-Q□BDE model and GT2505HS-VTBD

For cells filled in grey, the specifications remain even after replacement.

Table 3-3 Comparison in performance specifications

Item	Model in use		Recommended model for replacement
	GT1455HS-QTBDE	GT1450HS-QMBDE	GT2505HS-VTBD
Conforming standards	CE(EMC), UL/cUL, KC		←
Display section	Type	TFT color liquid crystal	TFT monochrome (white/black) liquid crystal
	Screen size	5.7"	
	Resolution	QVGA : 320 x 240[dots]	
	Display size	W115(4.53) x H86(3.39)[mm](inch)	
	Display character	16-dot standard font: 20 characters x 15 lines 12-dot standard font: 26 characters x 20 lines	
	Display color	65536 colors	Monochrome (white/black), 16 scales
	Intensity adjustment	8-level adjustment	
Backlight	Model	LED type (irreplaceable)	
	Function	Backlight off/screen saving time can be set.	
	Life	Approx. 70,000h or longer. (Time for display intensity reaches 50% at operating ambient temperature of 25 °C)	
Touch panel	Type	Analog resistive film	
	Key size	Minimum 2 x 2 dots (per key)	
	Number of points touched simultaneously	Simultaneous presses not allowed.	
	Life	1 million times (operating force 0.98N max.)	
Memory	User memory	Built-in flash memory, 9Mbytes Life (Number of write times): 100,000 times	
	Built-in SRAM	Drive D: 512KB	
Battery	Model	GT11-50BAT lithium battery	
	Life	Approx. 5 years (Operating ambient temperature of 25 °C)	

[Issue No.] GOT-A-0125-F

Item			Model in use		Recommended model for replacement
			GT1455HS-QTBDE	GT1450HS-QMBDE	GT2505HS-VTBD
Built-in interface	RS-422	Specifications	1 channel each (When using, select 1ch either, simultaneous use with Ethernet is not possible) Connector shape: Round type 32pins (Male)		←
	RS-232	Specifications	1 channel Data transfer method: 100BASE-TX, 10BASE-T, Connector shape: RJ-45 (modular jack)		←
	Ethernet		1 channels, Maximum transfer rate: Full Speed 12Mbps, Connector shape: USB Mini-A		1 channels, Maximum transfer rate: High-Speed 480 Mbps, Connector shape: USB-A
	USB (host)		1 channels, Maximum transfer rate: Full Speed 12Mbps, Connector shape: Mini-B		1 channels, Maximum transfer rate: High-Speed 480 Mbps, Connector shape: USB Mini-B
	USB (device)		1 channel, SDHC compliant (maximum 32 GB)		←
SD card		Single tone (tone length adjustable)		Single tone (tone and tone length adjustable)	
Buzzer output			2 colors (green and orange)		2 colors (blue and orange)
POWER LED			I IP65f (valid when the external cable is connected)		←
Protective structure			145(5.71)(W) × 185(7.28)(H) × 79.3(3.12) (D) mm(inch)		←
External dimensions			153(6.02)(W) × 121(4.76) (H) mm(inch)		←
Panel cutting dimension			0.79kg		←
Weight (Excluding mounting fixtures)			GT Designer3 Version1.71Z or later		GT Designer3 Version1.195D or later
Compatible software package					

[Issue No.] GOT-A-0125-F

3.1.4 Comparison in power supply specifications between the GT145□HS-Q□BDE model and GT2505HS-VTBD

For cells filled in grey, the specifications remain even after replacement.

Table 3-4 Comparison in power supply specifications

Item	Model in use		Recommended model for replacement
	GT1455HS-QTBDE	GT1450HS-QMBDE	GT2505HS-VTBD
Input power supply voltage	24VDC (+10% -15%), ripple voltage 200mV or less		←
Power consumption (Under the maximum load)	8.4W(350mA/24V)	7.5W(350mA/24V)	8.40 W or less
Inrush current	30 A or less (2 ms, operating ambient temperature 25 °C, maximum load)		←
Permissible instantaneous power failure time	5 ms or less		10 ms or less
Noise immunity	1000 Vp-p noise voltage, 1s noise width (when measuring with a noise simulator under 30 to 100 Hz noise frequency)		←
Withstand voltage	500 V AC for 1 minute across power terminals and earth		←
Insulation resistance	500 V DC across power terminals and earth, 10 MΩ or more by an insulation resistance tester		←

3.2 External dimension comparison

■GT14 model

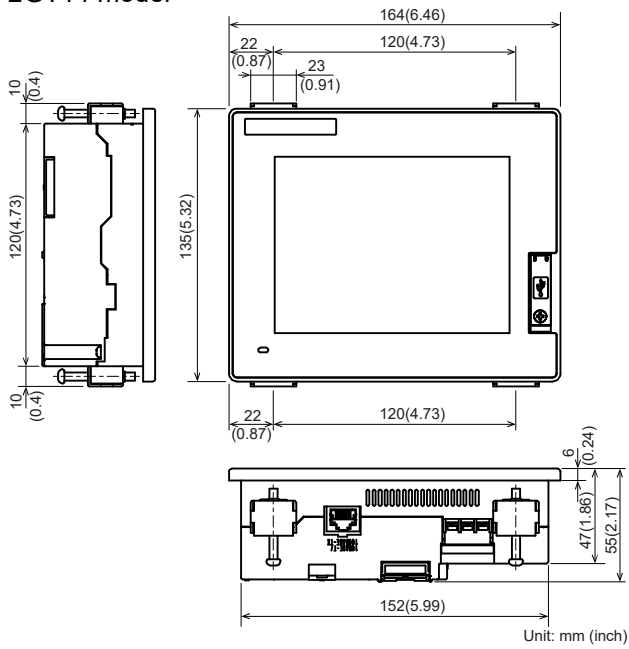

■GT2505-VTBD

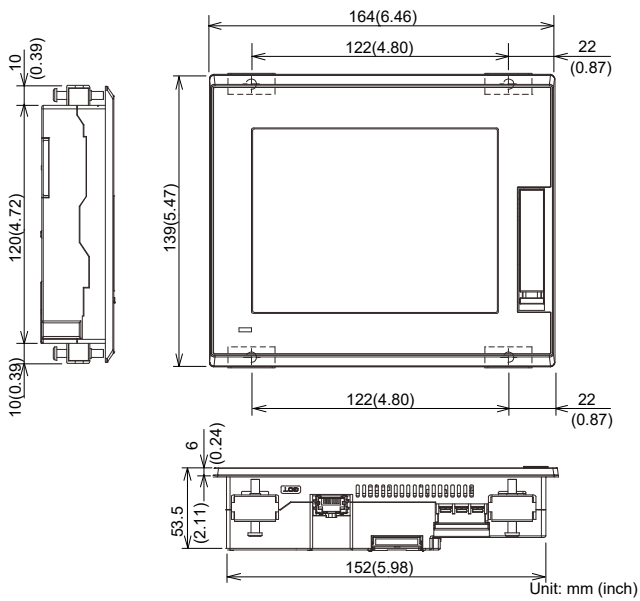

[Issue No.] GOT-A-0125-F

■GT14 Handy model

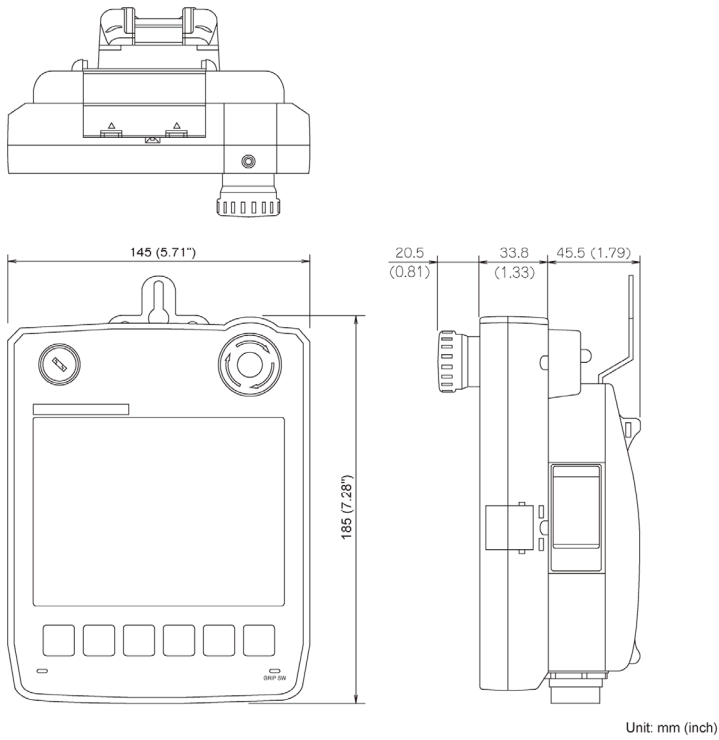

■GT2505HS-VTBD

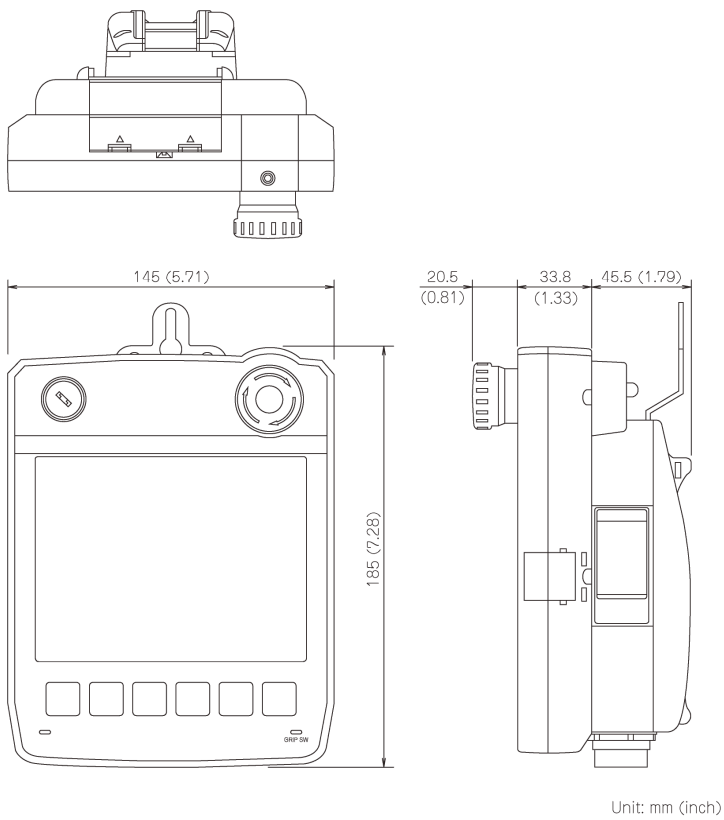

3.3 Panel cutting dimension comparison

■Horizontal installation

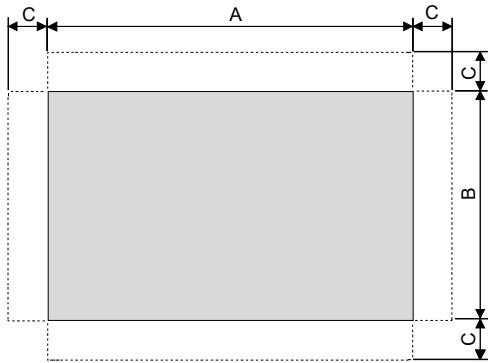

■Vertical installation

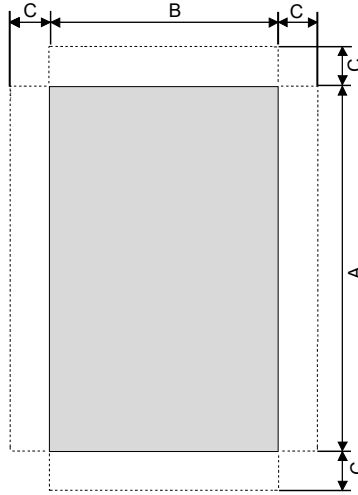

For cells filled in grey, the specifications remain even after replacement.

Item	Model in use	Recommended model for replacement
	GT14 model	GT2505-VTBD
A	153(6.02) ^{+2(0.08)} ₋₀₍₀₎ mm (inch)	←
B	121(4.76) ^{+2(0.08)} ₋₀₍₀₎ mm (inch)	←
C	10(0.39) mm (inch) or more	←
Panel thickness	2(0.08) to 4(0.16) mm (inch)	1.6(0.06) to 4(0.16) mm (inch)

3.4 Mounting intervals

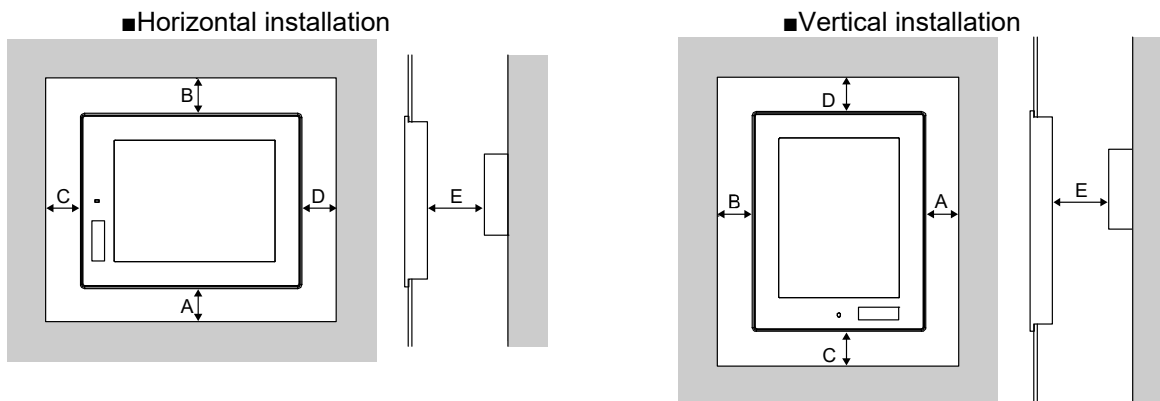

For cells filled in grey, the specifications remain even after replacement.

Item	Model in use	Recommended model for replacement
	GT14 model	GT2505-VTBD
A	50(1.97) or more [20(0.79) or more] mm (inch)	←
B	Horizontal: 80(3.15) or more [20(0.79) or more] mm (inch) Vertical: 50(1.97) or more [20(0.79) or more] mm (inch)	←
C	Horizontal: 50(1.97) or more [20(0.79) or more] mm (inch) Vertical: 80(3.15) or more [20(0.79) or more] mm (inch)	←
D	50(1.97) or more [20(0.79) or more] mm (inch)	←
E	100(3.94) or more [20(0.79) or more] mm (inch)	←

* The dimensions within the parentheses apply when no equipment generating radiated noise (such as a contactor) or heat is installed near the GOT.

[Issue No.] GOT-A-0125-F

3.5 Function specifications**3.5.1 Comparison in functions**

Most of the functions of the GOT1000 series can be used in the GOT2000 series; however, some functions are not supported or are integrated, or their names have been changed. For the details, refer to "Table 3-5 GOT2000 function comparison table".

For each function of the GOT2000 series, refer to the manual.

(1) Functions not supported by the GOT2000 series

- Data list display
- A list editor
- Multiple GOT connection

(2) Integrated functions and functions with changed names

Function name in GOT1000	Function name in GOT2000
Basic comment	Comment group
Comment group	
Alarm history, alarm history display	User alarm observation, alarm display (user)
Advanced user alarm observation, advanced user alarm display	
Recipe	Recipe
Advanced recipe	
Status observation function	Trigger action
Trigger action	
ASCII display, ASCII input	Text Display/Input
User alarm display	Simple Alarm display
Advanced system alarm observation, advanced system alarm display	System alarm observation, alarm display (system)
Advanced alarm popup display	Alarm Popup Display
System monitor	Device monitor
Stroke font	Outline font

3.5.2 Detailed comparison in functions

(1) Detailed comparison in functions

The following tables shows the differences in the functions between the GOT1000 series and GOT2000 series.

Table 3-5 GOT2000 function comparison table

Item	Function name in GOT1000	GT14	GT2505-V	Precautions for replacing GOT1000 series with GOT2000 series	
Figure/object function	Shapes	Shapes	●	●	-
		Logo Text	●	●	-
	Font type	Standard Font	●	●	[Precautions] - Refer to Section 3.6.4(2)
		HQ font	●	●	-
		TrueType font	●	●	-
		Stroke font	●	●	[Precautions] - Converted into Outline font (Outline Gothic).
		Windows font	●	●	-
		Common	Text	●	●
	Trigger type		●	●	-
	Offset device		●	●	[Precautions] - Refer to Section 3.6.4(2)
	Number of colors		●	●	[Precautions] - Since the number of colors differs depending on the model, replacing GT1450(HS) with GT2505(HS) may change the colors of the switches and other items to unintended colors. Change the colors using the batch edit function as necessary. For how to change colors, refer to the following. → GT Designer3 (GOT2000) Screen Design Manual
	Object	Buffer memory unit No. switching	●	●	-
		Touch switch	●	●	[Precautions] - The special function switches that GOT2000 does not support are replaced with [Utility]. - When multiple actions have been set on a switch and no device has been set to one of the actions in the [Action] tab, touching the switch may not perform actions after the action to which no device has been set.
		Lamp	●	●	[Precautions] - The [Use Image Transparent] setting for when objects registered in the library are used will be deleted. Transparent color is effective in GOT2000 regardless of the settings in GOT1000.
		Numerical Display/Input	●	●	-
		ASCII display/input	●	●	-
		Date/Time Display	●	●	-
		Comment Display	●	●	[Precautions] - When [16dot HQ Mincho] or [16dot HQ Gothic] is specified for comment display (bit), the setting is replaced as follows. - When the text size (width × height) is any of 0.5, 1, 3, 5, or 7: The font selected in [16dot Standard Font] in the type setting of GOT1000. 2, 4, 6, or 8: [16dot HQ Mincho]

- (Without version) : Supported by GT Works3 Ver1.180N or later
- Ver1.**** : Supported by the written version
- × : Not supported by the GOT2000 series

[Issue No.] GOT-A-0125-F

Item	Function name in GOT1000	GT14	GT2505-V	Precautions for replacing GOT1000 series with GOT2000 series	
Figure/object function	Object	Basic comment	●	●	[Precautions] - Replaced with [Comment Group]. - [Basic Comment] is replaced with the comment group No. 256.
		Comment group	●		
	Parts Display	●	●	[Precautions] - When [Fixed Parts Display] is used, [Rise] and [Fall] are replaced with [ON] and [OFF].	
	Parts movement	●	●	-	
	Data list display	●	×	[Precautions] - Not supported by GOT2000.	
	User alarm display	●	●	[Precautions] - Replaced with [Simple Alarm Display]. - [Rise], [Fall], and [Sampling] of the trigger type setting are replaced with [Ordinary]. - Text alignment of the comment setting (multiple rows) will be deleted. Text are aligned left in GOT2000 regardless of the setting of GOT1000. - [Store Memory] is not supported. When [Store Memory] is used, replace it with [User Alarm Observation] or [Alarm Display(User)].	
	System Alarm Display	●	●	-	
	Historical Data List Display	●	●	-	
	Alarm history, alarm history display	●	●	[Precautions] - Replaced with [User Alarm Observation] or [Alarm Display(User)]. - Replaced with [Time (hh:mm)] when [Text] is set as the date/time format for [Occurred], [Restored], and [Checks] of the displayed items in [Alarm History Display]. - When [CREATE A CSV FILE SIMULTANEOUSLY] is selected in [Alarm History], set the setting again in [Alarm Common Setting] of [User Alarm Observation] with GOT2000. - GT2505-V cannot be saved in the drive D. Use the data storage since the drive D is replaced with the drive X. For the available drives, refer to Section 3.6.4 (3).	
	Advanced user alarm observation, advanced user alarm display	●			
	Advanced system alarm observation, advanced system alarm display	●	●	[Precautions] - Replaced with [System Alarm Observation] or [Alarm Display(System)]. - GT2505-V cannot be saved in the drive D. Use the data storage since the drive D is replaced with the drive X. For the available drives, refer to Section 3.6.4 (3).	
	Advanced alarm popup display	●	●	[Precautions] - Replaced with [Alarm Popup Display].	
	Level object	●	●	-	
	Panel Meter	●	●	[Precautions] - [Top 1/4], [Bottom 1/4], [Left 1/4], and [Right 1/4] are replaced with [Top 1/6], [Bottom 1/6], [Left 1/6], and [Right 1/6] respectively. The display size is not changed.	
	Line Graph	●	●	[Precautions] - [Locus] is not supported.	
Trend Graph	●	●	[Precautions] - Replaced with [Historical Trend Graph] or [Logging] when [Store Memory] is set. However, this function will be deleted when the number of logging settings exceeds the upper limits.		

- (Without version) : Supported by GT Works3 Ver1.180N or later
- Ver1.**** : Supported by the written version
- ×
- × : Not supported by the GOT2000 series

[Issue No.] GOT-A-0125-F

Item	Function name in GOT1000	GT14	GT2505-V	Precautions for replacing GOT1000 series with GOT2000 series	
Figure/object function	Object	Bar Graph	●	●	-
		Statistics Bar Graph	●	●	-
		Statistics per screen	●	●	-
		Scatter Graph	●	●	-
		Historical Trend Graph	●	●	-
		Key Window Object	●	●	-
Functions performed on background	Logging	●	●	-	
	Recipe	●	●	[Precautions]	
	Advanced recipe	●		<ul style="list-style-type: none"> - Replaced with [Recipe], which is equivalent to the advanced recipe of GOT1000. - The number of advanced recipe of GOT1000 is replaced with those with the same recipe number in GOT2000. - When a trigger condition is satisfied, the recipes set in GOT1000 are collectively processed, whereas the recipes set in GOT2000 are processed per recipe number. - The recipe number used in GOT1000 is replaced with the recipe number after the advanced recipe number used in GOT1000. - The following function is not supported. <ul style="list-style-type: none"> · Creating a recipe file automatically if no recipe file is found at startup · Specifying the file register name - The format of recipe file (CSV/Unicode text) is different. When using a recipe file of GOT1000 in GOT2000, change the format into the one for GOT2000. For the details, refer to Section 3.2.2(2). - GT2505-V cannot be saved in the drive D. Use the data storage since the drive D is replaced with the drive X. For the available drives, refer to Section 3.6.4 (3). 	
	Device data transfer	●	●	-	
	Status observation function	●	●	[Precautions]	
	Trigger action	●		<ul style="list-style-type: none"> - Replaced with [Trigger Action]. - Because the trigger action has no [Observation Cycle] setting, the setting is replaced with one of [ON Sampling], [OFF Sampling], and [Ordinary] in the [Trigger Type] setting when the [Observation Cycle] setting has been set. Thus, the action timing in the first cycle may change. 	
	Time action	●	●	[Precautions] <ul style="list-style-type: none"> - GT2505-V cannot be saved in the drive D. Use the data storage since the drive D is replaced with the drive X. For the available drives, refer to Section 3.6.4 (3). 	
	Hard copy (File output)	●	●	[Precautions] <ul style="list-style-type: none"> - The setting of the trigger watch cycle will be deleted. The trigger watch cycle is set to [Ordinary] regardless of the setting in GOT1000. - GT2505-V cannot be saved in the drive D. Use the data storage since the drive D is replaced with the drive X. For the available drives, refer to Section 3.6.4 (3). 	
	Hard copy (Serial printer output)	●	●	[Precautions] <ul style="list-style-type: none"> - The setting of the trigger watch cycle will be deleted. The trigger watch cycle is set to [Ordinary] regardless of the setting in GOT1000. 	

- (Without version) : Supported by GT Works3 Ver1.180N or later
- Ver1.**** : Supported by the written version
- x : Not supported by the GOT2000 series

Item	Function name in GOT1000	GT14	GT2505-V	Precautions for replacing GOT1000 series with GOT2000 series
Functions performed on background	Project/screen script	●	●	<p>[Precautions]</p> <ul style="list-style-type: none"> - The setting of [Cancel internal device (GD/GB) assignment delay] will be deleted. In GOT2000, the result of assignment of internal devices (GD/GB) is reflected immediately regardless of the setting in GOT1000 - [Perform script initial operation (screen/object) only when switching screens] is added to GOT2000. The setting will be replaced as follows. <ul style="list-style-type: none"> When using GT Designer3 Version1.103H or earlier: Checked When using GT Designer3 Version1.105K or later: Not checked (compatible with GOT1000) - The trigger type of a script is replaced as shown below. <ul style="list-style-type: none"> · [Ordinary] → [Sampling] (Cycle time: 100 ms) · [ON] → [ON Sampling] (Cycle time: 100 ms) · [OFF] → [OFF Sampling] (Cycle time: 100 ms) - When the drive D is specified with the file operation function, change the designated location of the drive. For the available drives, refer to Section 3.6.4 (3).
	Object Script	●	●	<p>[Precautions]</p> <ul style="list-style-type: none"> - [Perform script initial operation (screen/object) only when switching screens] is added to GOT2000. The setting will be replaced as follows. <ul style="list-style-type: none"> When using GT Designer3 Version1.103H or earlier: Checked When using GT Designer3 Version1.105K or later: Not checked (compatible with GOT1000)
FUNCTIONS USED WITH PERIPHERAL DEVICES	Barcode	●	●	-
	RFID	●	●	-
	GOT remote access function (VNC server function)	●	●	[Precautions] - Purchase separately since the license is different.
	Gateway function (Server function, client function)	●	●	-
	Gateway function (Mail send function)	●	●	-
	Gateway function (FTP server function)	●	●	[Precautions] - GT2505-V cannot be saved in the drive D. For the available drives, refer to Section 3.6.4 (3).
GOT function	Gateway function (File transfer (FTP client) function)	●	●	[Precautions] - The save location is switched to the drive A. For the available drives, refer to Section 3.6.4 (3).
	Base screen	●	●	-
	Overlap window	●	●	-
	Superimpose window	●	●	-
	Dialog window	●	●	-
	Key window	●	●	-
	Language Switching	●	●	-
	System information	●	●	-
	Operator authentication	●	●	-
	Security level authentication	●	●	-
	Startup Logo	●	●	-
	KANA-KANJI Conversion	●	●	-
	FA transparent	●	●	[Precautions] - Modem connection and RS-232 connection between the GOT and a personal computer are not supported.
	Backup/Restore	●	●	[Precautions] - GT Refer to Section 3.3.4(6).
	Multi-channel function	●	●	-
Station No. Switching	●	●	-	

●(Without version) : Supported by GT Works3 Ver1.180N or later
 ●Ver1.**** : Supported by the written version
 × : Not supported by the GOT2000 series

[Issue No.] GOT-A-0125-F

Item	Function name in GOT1000	GT14	GT2505-V	Precautions for replacing GOT1000 series with GOT2000 series
Debug function	System monitor	●	●	[Precautions] - Replaced with [Device monitor]. - The display method for device comments is the same as the one for the sequence program monitor.
	A list editor	●	×	[Precautions] - Not supported by GOT2000. - The special function switch [MELSEC-A LIST EDITOR] is replaced with [Utility].
	List editor for FX	●	●	-

*1 Excluding GT14 Handy GOT.

*2 Excluding GT25 Handy GOT.

- (Without version) : Supported by GT Works3 Ver1.180N or later
- Ver1.**** : Supported by the written version
- × : Not supported by the GOT2000 series

(2) Recipe files (CSV/Unicode text) of the recipe and advanced recipe

The format of the recipe files (CSV/Unicode text) differs between the GOT1000 series and GOT2000 series.

When using a recipe file (CSV/Unicode text) for the GOT1000 series in the GOT2000 series, change the format into the one for the GOT2000 series.

- 1) For the recipe
 - (a) Convert the project data into the GOT2000 series project data, and execute the recipe.
 - (b) A recipe file for the GOT2000 series (CSV/Unicode text) is created in the specified drive.
 - (c) Copy the device values in the recipe file for the GOT1000 series onto the corresponding section in the recipe file for the GOT2000 series.

- GOT1000 recipe file

	2014/1/31 12:38
:DATE	PM
:GROUP No.	1
:GROUP NAME	RECIPE1
:DEVICE	8
ITEM NAME	VALUE
	234
	421
	52
	-23
	534
	-3
	32
	0

Copy and paste these values onto the GOT2000 recipe file.

- GOT2000 recipe file (number of records: 1)

:GT2K_RECIPE	0				
:RECIPE_ID	1				
:RECIPE_NAME	RECIPE1				
:DEVICE_NUM	8				
:RECORD_NUM	1				
:DATE_ORDER	YYYY/MM/DD				
	hh:mm:ss				
:LOCAL_TIME	GMT+09:00				
:TIME_INF_ORDER	L				
	DEV_COMMENT	DEV_TYPE	DISP_TYPE	DEV_SIZE	1
:RECORD_NAME					
:RECORD_ATTR					
:UPDATE					2014/1/31 12:38 PM
1		BIN16	DEC		234
2		BIN16	DEC	1	421
3		BIN16	DEC	1	52
4		BIN16	DEC	1	-23
5		BIN16	DEC	1	534
6		BIN16	DEC	1	-3
7		BIN16	DEC	1	32
8		BIN16	DEC	1	0

[Issue No.] GOT-A-0125-F

2) For the advanced recipe

- (a) Convert the project data into the GOT2000 series project data, and execute the recipe.
- (b) A recipe file for the GOT2000 series (CSV/Unicode text) is created in the specified drive.
- (c) Copy the device values in the recipe file for the GOT1000 series onto the corresponding section in the recipe file for the GOT2000 series.
- (d) When using the file in the GOT, convert the file format from CSV/Unicode text to binary in either of the following procedure.
 - Utility of the GOT - GT Designer3 (GOT2000) - Data Transfer Tool

- GOT1000 advanced recipe file (number of records: 2)

:ARECIPE						
:ARECIPE_No		1				
:ARECIPE_NAME	RECIPE1					
:DEVICE_NUM		8				
:RECORD_NUM		2				
	DEV_COMMENT	DEV_TYPE	DISP_TYPE	DEV_SIZE	1	2
:RECORD_NAME					PRO1	PRO2
:RECORD_ATTR					P	
:UPDATE					2014/1/31 10:30:15	2014/1/31 10:30:15
1	STD A	BIN16	DEC	2	454	400
2	CNT1	BIN16	UNSIGNED_DEC	2	10000	40000
3	LINE A	BIN16	DEC	2	10000	40000
4	LINE B	BIN16	DEC	2	10000	40000
5	LINE C	BIN16	DEC	2	10000	40000
6	CNT2	BIN32	DEC	4	120000000	200000000
7	TARGET1	BIN32	DEC	4	100000000	500000000
8	TARGET2	BIN32	UNSIGNED_DEC	4	200000000	600000000

Copy and paste these values onto the GOT2000 recipe file.

- GOT2000 recipe file

:GT2K_RECIPE		0				
:RECIPE_ID		1				
:RECIPE_NAME	RECIPE1					
:DEVICE_NUM		8				
:RECORD_NUM		2				
:DATE_ORDER	YYYY/MM/DD hh:mm:ss					
:LOCAL_TIME	GMT+09:00					
:TIME_INF_ORDER	L					
	DEV_COMMENT	DEV_TYPE	DISP_TYPE	DEV_SIZE	1	2
:RECORD_NAME					PRO1	PRO2
:RECORD_ATTR					P	
:UPDATE					2014/1/31 10:30:15	2014/1/31 10:30:15
1	STD A	BIN16	DEC	1	454	400
2	CNT1	BIN16	UNSIGNED_DEC	1	10000	40000
3	LINE A	BIN16	DEC	1	10000	40000
4	LINE B	BIN16	DEC	1	10000	40000
5	LINE C	BIN16	DEC	1	10000	40000
6	CNT2	BIN32	DEC	2	120000000	200000000
7	TARGET1	BIN32	DEC	2	100000000	500000000
8	TARGET2	BIN32	UNSIGNED_DEC	2	200000000	600000000

[Issue No.] GOT-A-0125-F

3.6 Screen design software specifications

The project data used in the GOT1000 series can be converted into the project data for the GOT2000 series, and can be used as-is.

[Precautions]

This explanation is based on GT Works3 Version1.180N.

Once the project data is converted for the GOT2000 series, it cannot be converted back into the project data for the GOT1000 series.

For GT25 Handy GOT, GT Works3 Version1.195D is used.

3.6.1 Preparation before converting the project data

Install the following software into the personal computer in advance.

(1) When reading the project data for the GOT1000 series from a GOT
Install GT Designer3 (GOT1000) (GT Works3 Version1.180N or later) or Data Transfer Tool.

* Not necessary if any project data already exists in the personal computer.

(2) When converting the project data for the GOT2000 series
Install GT Designer3 (GOT2000) (GT Works3 Version1.180N or later).

For how to install the software, refer to the following.

- GT Works3 Installation Instructions (DVD version) (BCN-P5999-0066)

3.6.2 Procedure for the project data conversion

1) When the data exists on the personal computer, check the storage location of the project data for the GOT1000 series.

When no data exists on the personal computer, connect the personal computer to the GOT1000 series, and read and save the project data using GT Designer3 (GOT1000) or Data Transfer Tool.

2) Open the project data of procedure 1) with GT Designer3 (GOT2000), and select [Convert the project to GOT2000 data and edit it in GT Designer3 (GOT2000)].

* To open the GOT1000 series project data, select [Start GT Designer3(GOT1000) and edit the GOT1000 data as is].

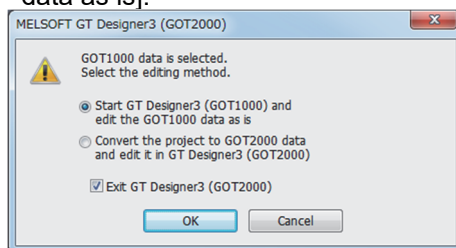

[Issue No.] GOT-A-0125-F

When the project data of procedure 1) is opened in GT Designer3 (GOT1000), select [Common]-[GOT Type Setting], select [GOT2000] in [Series] of [GOT Type], and press [OK].

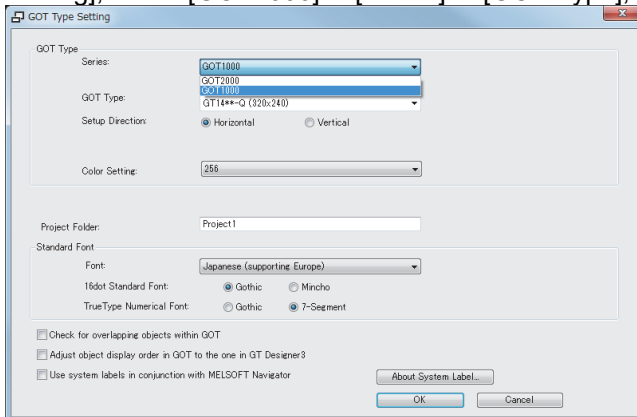

3) Select the model of GOT2000 after replacement, and press [OK].

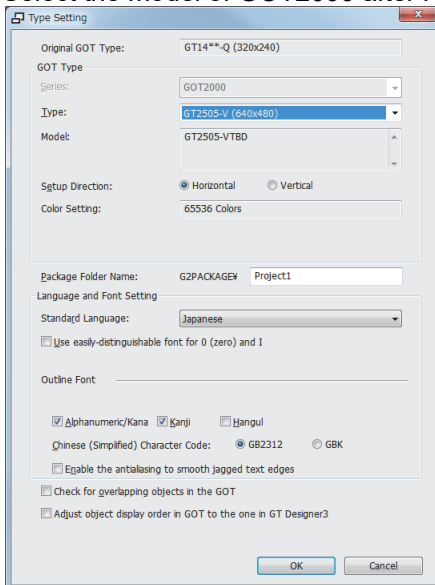

4) The project data is converted for the GOT2000 series, and GT Designer3 (GOT2000) starts. The conversion result can be checked in the [Output] window.

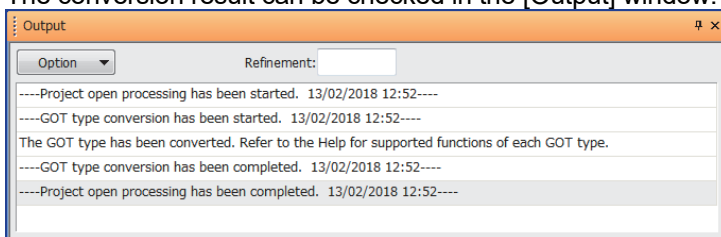

[Issue No.] GOT-A-0125-F

3.6.3 Screen design functions that are not supported

The following screen design functions are not supported.

Item	Screen design function	GT14	GT2505-V	Precautions for GOT1000-to-GOT2000 replacement
Screen design software	Communication between the screen design software and GOT (modem, RS-232)	●	×	[Precautions] Modem or RS-232 connection between the screen design software and GOT is not supported. Use USB or Ethernet connection.

●(Without version) : Supported by GT Works3 Ver1.180N or later
 × : Not supported by the GOT2000 series

[Precautions]

Note that the settings of the functions that are not supported in the GOT2000 series are deleted when the GOT1000 series project data is converted for the GOT2000 series. For compatibility of the functions between the GOT2000 series and GOT1000 series, refer to Section 3.2.

3.6.4 Other major changes

Major changes in the screen design function are as follows.

(1) Name of the OS (standard monitor OS, extended function OS)

The name is changed as follows. In the GOT2000 series, the data necessary for GOT operations including system applications, project data, and communication drivers are collectively called "package data".

Name in GOT1000	Name in GOT2000
OS	System application
Standard monitor OS	Standard system application
Extended function OS	Advanced system application

(2) Name of standard fonts

The name and type of the standard fonts are changed as follows.

Name in GOT1000	Precautions and names changed in GOT1000-to-GOT2000 replacement
Japanese *1	Japanese *3 * Replaced to a font equivalent to Japanese (supporting Europe) of the GOT1000 series.
Japanese (supporting Europe) *2	Japanese *3
Chinese (Simplified) *1	Chinese (Simplified) *3 * Replaced to a font equivalent to Chinese (Simplified) (supporting Europe) of the GOT1000 series.
Chinese (Simplified) (supporting Europe) *2	Chinese (Simplified) *3
Chinese (Traditional) (supporting European) *2	Chinese (Traditional) *3

*1 European characters (Latin-1 Supplement, Latin Extended-A, Basic Greek, and Cyrillic) are displayed in two-byte characters.
 *2 European characters (Latin-1 Supplement, Latin Extended-A, Basic Greek, and some of Cyrillic) are displayed in one-byte characters.
 *3 European characters (Latin-1 Supplement, Latin Extended-A, Latin Extended-B, IPA Extensions, Latin Extended Additional, Basic Greek, Greek Extended, and some of Cyrillic) are displayed in one-byte characters.

[Issue No.] GOT-A-0125-F

(3) Drive configuration of the GOT

The name and type (media) of drives are different as follows.

Drive name	Drive type	
	GT14	GT2505-V
Drive A	Standard CF card	Standard SD card
Drive C	Built-in flash memory	Built-in flash memory
Drive D	Built-in SRAM	-
Drive E	USB	USB (assigned in order of connection)
Drive F	-	USB (assigned in order of connection)
Drive G	-	USB (assigned in order of connection)
Drive X (Current drive)	-	A drive that is running a project. (Indicates A drive when the project is started from C drive.)

(4) Storage locations of data

The storage locations of data are different as follows.

Data type	Storage drive	
	GT14	GT2505-V
OS	A, C drive	Package data A, C, E, F, G drive * Project data and system application must be stored in the same drive. * Only A drive can be used for direct startup from a memory card.
Project data	A, C drive * Only A drive can be used when the OS is stored in A drive.	
Resource data	A, D, E drive * Storage locations differ depending on the type.	E, F, G drive

[Issue No.] GOT-A-0125-F

(5) GOT setup settings (backup/restore)

Setting categories in the screen design software for the GOT2000 series differ. Depending on the settings, those in GOT1000 may be deleted. Check and set them again in the screen design software for the GOT2000 series if necessary.

Setting categories in the screen design software for the GOT1000 series "GT Designer3 (GOT1000)"
[Common]-[Environmental Setting]-[GOT Setup]

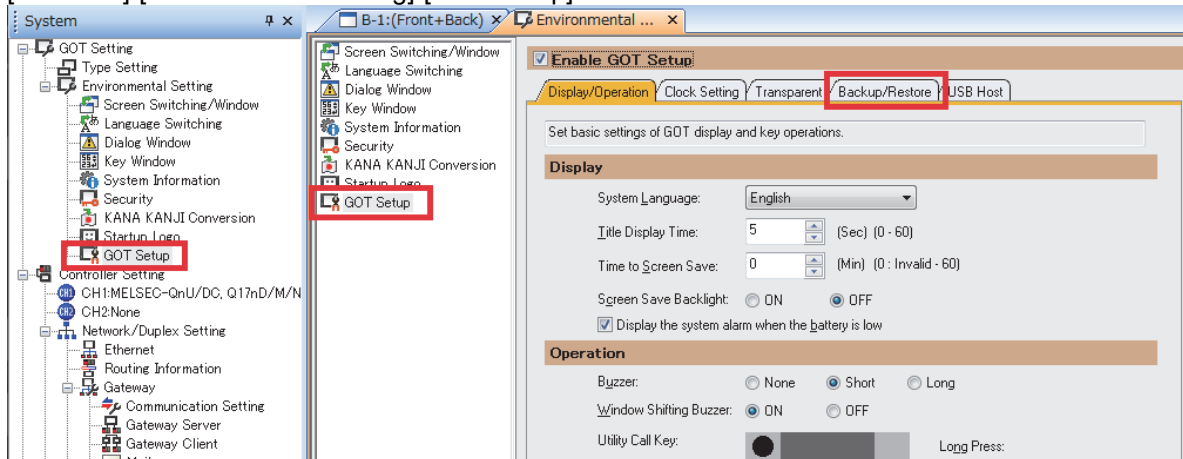

Setting categories in the screen design software for the GOT2000 series "GT Designer3 (GOT2000)"
[Common]-[GOT Setup]-[Advanced Setting]

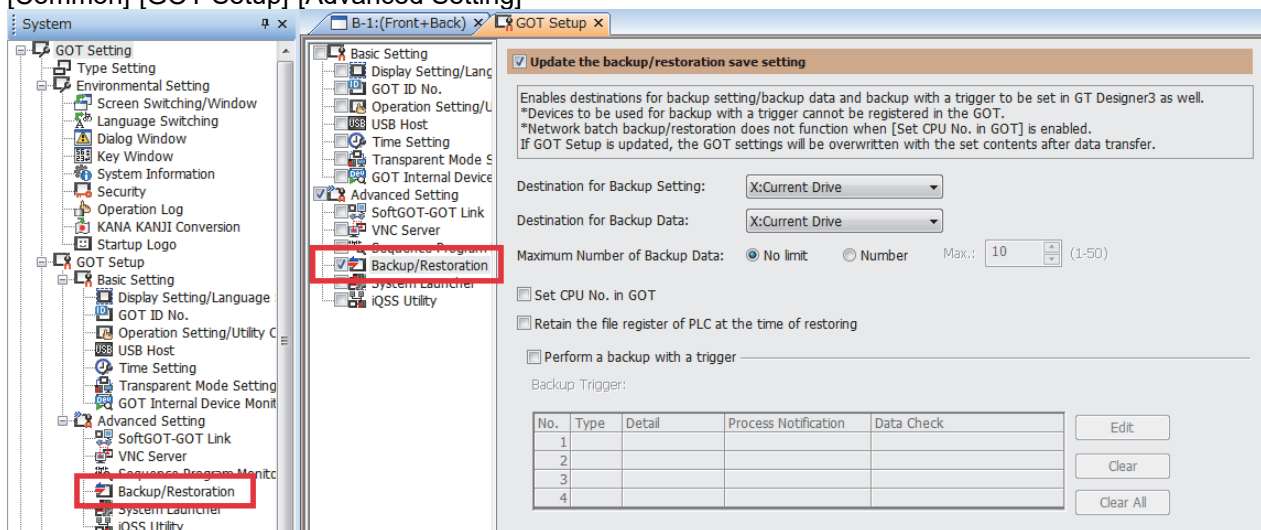

* Settings can be made with the utility of the GOT.

[Issue No.] GOT-A-0125-F

(6) Offset value setting

When offsets are used and the following conditions are satisfied, the values stored in the offset devices must be changed.

1) Conditions requiring changes

- Controller: OMRON PLC
- Connection type: Serial connection or Ethernet connection
- Offset-target device: Bit devices (., LR, HR, WR, and AR)

2) Change method

Values stored in the offset devices can be calculated using the following expression. Store the result in the offset devices.

$$\text{Offset value for the GOT2000 series} = (\text{Offset value for the GOT-A900 series}) / 100 \times 16 + (\text{Offset value for the GOT-A900 series}) \% 100$$

* % means the division to calculate a remainder. (For "a % b", a remainder after "a" is divided by "b" is returned.)

Example) The following shows an example of offset values for the device LR00000.

Object setting in the GOT	Device number after the offset is added	Offset value for the GOT-A900 series (decimal)	Offset value for the GOT2000 series (decimal) (calculated by the expression)
LR00000	LR00010	10	10
	LR00100	100	16
	LR00310	310	58
	LR010000	10000	1600

3) Difference in the specifications of the offsets of bit devices (., LR, HR, WR, and AR)

In the GOT1000 series, values must be set corresponding to the device notation (channel number and bit position). In the GOT2000 series, values disregarding channel numbers are set while bit devices are considered continuous.

Example) The following shows an example for the GOT1000 series.

Offset	Device indicated by the monitor device
Offset value = 0 (no offset)	LR00000
Offset value = 1	LR00001
Offset value = 15	LR00015
Offset value = 16	322 (range error)
Offset value = 100	LR00100
Offset value = 115	LR00115

*1 The notation of bit devices is as follows (example of LR):



*2 The lower two digits of the offset value are applied as an offset value for the bit position in *1. The valid value is 0 to 15. If 16 to 99 is set, the system alarm 322 "Dedicated device is out of range. Confirm device range." is displayed.

The digits excluding the lower two digits of the offset value are applied as an offset value for the channel number.

