

Information for Replacement of FR-E700 Series with FR-E800 Series

Size, connection, parameters, options concerning replacement are stated on the following pages.

1. Size

When the FR-E700(SC) series is replaced with the FR-E800 series, some FR-E800 series models have different installation size from that of the corresponding FR-E700(SC) series models.

For more information about the product size, refer to the outline dimension drawings on the following pages.

Power supply voltage	Existing inverter	Replacing inverter	Installation size*1 / installation interchange attachment
Three-phase 200 V	FR-E720-0.1K(SC)	FR-E820-0.1K-1	Same
	FR-E720-0.2K(SC)	FR-E820-0.2K-1	Same
	FR-E720-0.4K(SC)	FR-E820-0.4K-1	Same
	FR-E720-0.75K(SC)	FR-E820-0.75K-1	Same
	FR-E720-1.5K(SC)	FR-E820-1.5K-1	Same
	FR-E720-2.2K(SC)	FR-E820-2.2K-1	Same
	FR-E720-3.7K(SC)	FR-E820-3.7K-1	FR-E8AT03
	FR-E720-5.5K(SC)	FR-E820-5.5K-1	Same
	FR-E720-7.5K(SC)	FR-E820-7.5K-1	Same
	FR-E720-11K(SC)	FR-E820-11K-1	Same
	FR-E720-15K(SC)	FR-E820-15K-1	Same
Three-phase 400 V	FR-E740-0.4K(SC)	FR-E840-0.4K-1	FR-E7AT02
	FR-E740-0.75K(SC)	FR-E840-0.75K-1	FR-E7AT02
	FR-E740-1.5K(SC)	FR-E840-1.5K-1	FR-E7AT02
	FR-E740-2.2K(SC)	FR-E840-2.2K-1	Same
	FR-E740-3.7K(SC)	FR-E840-3.7K-1	Same
	FR-E740-5.5K(SC)	FR-E840-5.5K-1	Same
	FR-E740-7.5K(SC)	FR-E840-7.5K-1	Same
	FR-E740-11K(SC)	FR-E840-11K-1	Same
FR-E740-15K(SC)	FR-E840-15K-1	Same	
Single-phase 200 V	FR-E720S-0.1K(SC)	FR-E820S-0.1K-1	Same
	FR-E720S-0.2K(SC)	FR-E820S-0.2K-1	Same
	FR-E720S-0.4K(SC)	FR-E820S-0.4K-1	Same
	FR-E720S-0.75K(SC)	FR-E820S-0.75K-1	Same
	FR-E720S-1.5K(SC)	FR-E820S-1.5K-1	Same
	FR-E720S-2.2K(SC)	FR-E820S-2.2K-1	FR-E8AT04
Single-phase 100 V	FR-E710W-0.1K	FR-E810W-0.1K-1	Same
	FR-E710W-0.2K	FR-E810W-0.2K-1	Same
	FR-E710W-0.4K	FR-E810W-0.4K-1	Same
	FR-E710W-0.75K	FR-E810W-0.75K-1	Same

*1 The depth required for installation differs depending on the inverter model. Refer to the outline dimension drawings on the following pages.

To remove the wiring cover of the FR-E800, insert a tool such as a flathead screwdriver into the half-hole above the "PUSH" mark on the cover, and pull out the cover along the guides.

Be sure to refer to the FR-E800 Instruction Manual (Connection).

When using the panel through attachment

[When used with the panel through attachment]

Existing inverter		Replacing inverter		Outline dimensions*1 / enclosure cut dimensions
Inverter model	Panel through attachment model	Inverter model	Panel through attachment model	
FR-E720-1.5K(SC)	FR-E7CN01	FR-E820-1.5K-1	FR-E8CN01	Attachment with side covers: Same dimensions Attachment without side covers: Additional enclosure cutting is required.
FR-E720-2.2K(SC)	FR-E7CN01	FR-E820-2.2K-1	FR-E8CN01	
FR-E720-3.7K(SC)	FR-E7CN02	FR-E820-3.7K-1	FR-E8CN02	Attachment with side covers: Some outline dimensions are different. Attachment without side covers: Some outline dimensions are different. Additional enclosure cutting is required.
FR-E720-5.5K(SC)	FR-E7CN03	FR-E820-5.5K-1	FR-E8CN03	Attachment with/without side covers: Same dimensions
FR-E720-7.5K(SC)	FR-E7CN03	FR-E820-7.5K-1	FR-E8CN03	
FR-E740-1.5K(SC)	FR-E7CN04	FR-E840-1.5K-1	FR-E8CN04	Attachment with/without side covers: Some outline dimensions are different. Additional enclosure cutting is required.
FR-E740-2.2K(SC)	FR-E7CN04	FR-E840-2.2K-1	FR-E8CN05	Attachment with side covers: Some outline dimensions are different. Attachment without side covers: Some outline dimensions are different. Additional enclosure cutting is required.
FR-E740-3.7K(SC)	FR-E7CN04	FR-E840-3.7K-1	FR-E8CN05	
FR-E740-5.5K(SC)	FR-E7CN05	FR-E840-5.5K-1	FR-E8CN06	Attachment with/without side covers: Same dimensions
FR-E740-7.5K(SC)	FR-E7CN05	FR-E840-7.5K-1	FR-E8CN06	
FR-E720S-1.5K(SC)	FR-E7CN01	FR-E820S-1.5K-1	FR-E8CN01	Attachment with side covers: Same dimensions Attachment without side covers: Additional enclosure cutting is required.
FR-E720S-2.2K(SC)	FR-E7CN04	FR-E820S-2.2K-1	FR-E8CN02	Attachment with/without side covers: Some outline dimensions are different. Additional enclosure cutting is required.

*1 The shape of the FR-E8CN differs from that of the FR-E7CN. For details, refer to the FR-E8CN Instruction Manual.
For details on the enclosure cut dimensions, refer to the FR-E8CN Instruction Manual.

[Depth]

When the FR-E700 is replaced with the FR-E800, the depths inside and outside the enclosure are different for some attachment models.

For details, refer to the FR-E8CN Instruction Manual.

■ FR-E720-0.1K(SC) to 0.75K(SC)

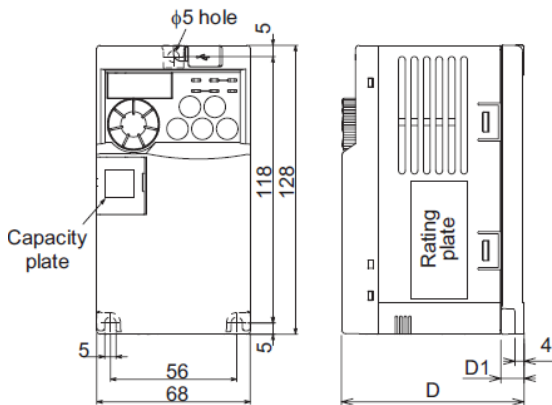

Inverter model	D	D1
FR-E720-0.1K, 0.2K	80.5	10
FR-E720-0.1KSC, 0.2KSC	86.5	10
FR-E720-0.4K	112.5	42
FR-E720-0.4KSC	118.5	42
FR-E720-0.75K	132.5	62
FR-E720-0.75KSC	138.5	62

When the plug-in option is installed, the depth required for installation is approx. 15.1 mm larger for the standard control circuit terminal model, and approx. 21.6 mm larger for the safety stop function model. *

* When the FR-A7NC (E kit) is used for the standard control circuit terminal model, or when the FR-A7NC and the FR-A7NC E kit safety cover SC are used for the safety stop function model, a terminal block protrudes forward and the depth is approx. 2 mm (up to 2.8 mm) larger.

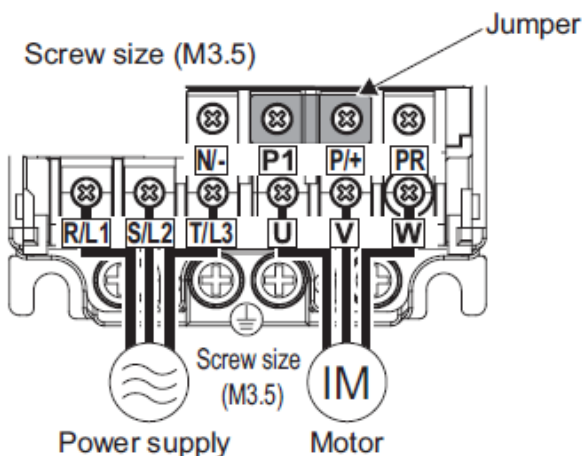

■ FR-E820-0.1K to 0.75K-1

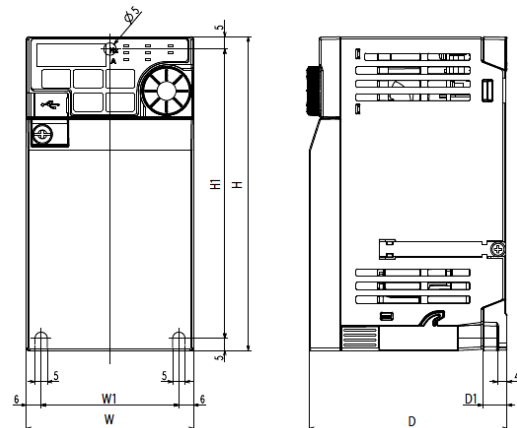

Inverter model	W	W1	H	H1	D	D1
FR-E820-0.1K, 0.2K	68	56	128	118	80.5	10
FR-E820-0.4K					112.5	42
FR-E820-0.75K					132.5	62

When the plug-in option is installed, the depth required for installation is approx. 27.6 mm larger.

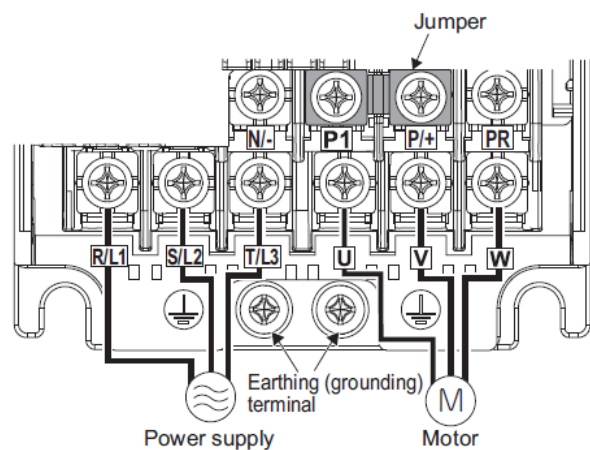

■ FR-E720-1.5K(SC), 2.2K(SC)

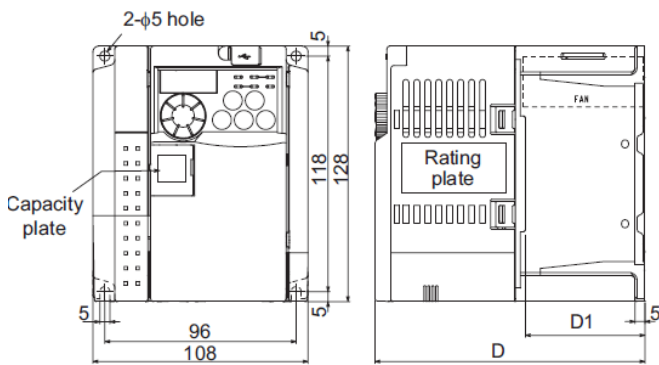

Inverter model	D	D1
FR-E720-1.5K, 2.2K	135.5	60
FR-E720-1.5KSC, 2.2KSC	141.5	60

When the plug-in option is installed, the depth required for installation is approx. 15.1 mm larger for the standard control circuit terminal model, and approx. 21.6 mm larger for the safety stop function model. *

* When the FR-A7NC (E kit) is used for the standard control circuit terminal model, or when the FR-A7NC and the FR-A7NC E kit safety cover SC are used for the safety stop function model, a terminal block protrudes forward and the depth is approx. 2 mm (up to 2.8 mm) larger.

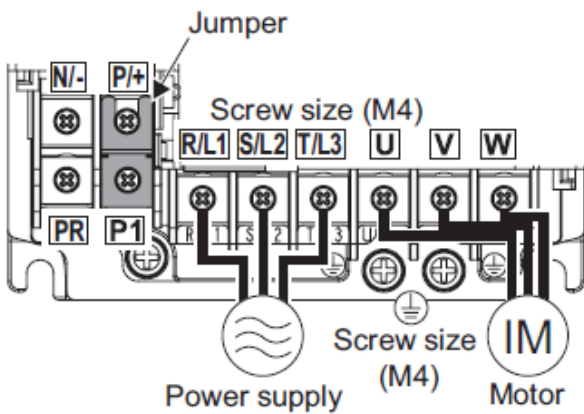

■ FR-E820-1.5K, 2.2K-1

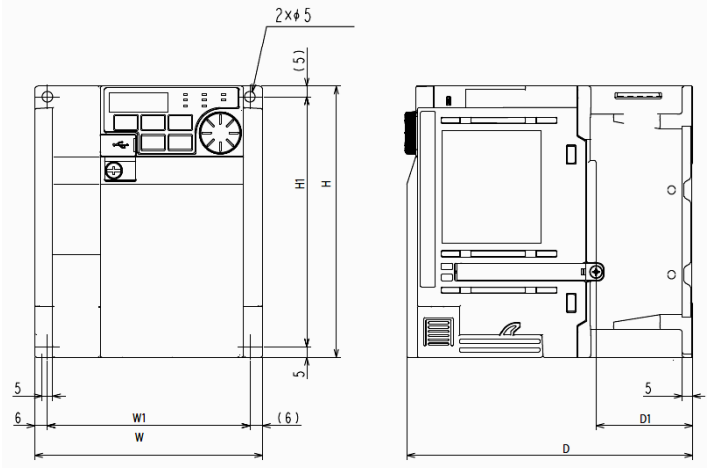

Inverter model	W	W1	H	H1	D	D1
FR-E820-1.5K, 2.2K	108	96	128	118	135.5	46

When the plug-in option is installed, the depth required for installation is approx. 27.6 mm larger.

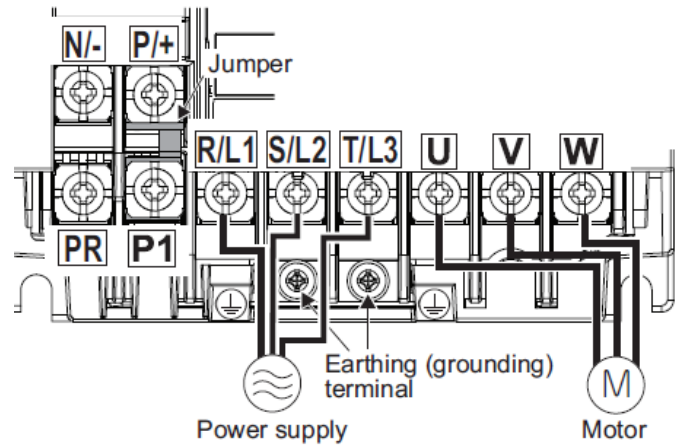

■ FR-E720-3.7K(SC)

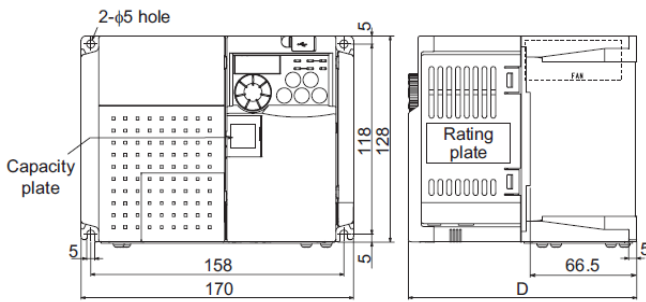

Inverter model	D
FR-E720-3.7K	142.5
FR-E720-3.7KSC	148.5

When the plug-in option is installed, the depth required for installation is approx. 15.1 mm larger for the standard control circuit terminal model, and approx. 21.6 mm larger for the safety stop function model. *

* When the FR-A7NC (E kit) is used for the standard control circuit terminal model, or when the FR-A7NC and the FR-A7NC E kit safety cover SC are used for the safety stop function model, a terminal block protrudes forward and the depth is approx. 2 mm (up to 2.8 mm) larger.

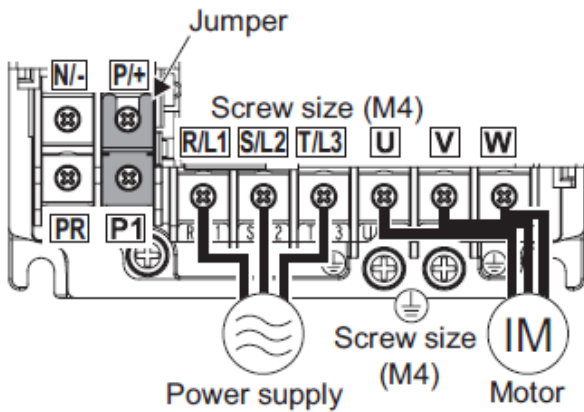

■ FR-E820-3.7K-1

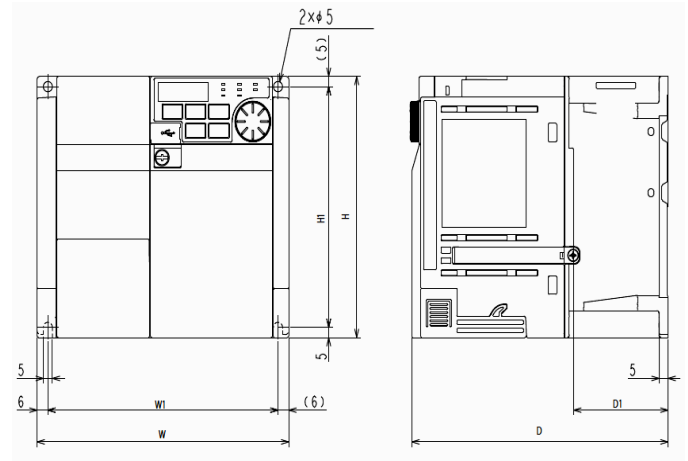

Inverter model	W	W1	H	H1	D	D1
FR-E820-3.7K	140	128	128	118	142.5	52.5

When the plug-in option is installed, the depth required for installation is approx. 27.6 mm larger.

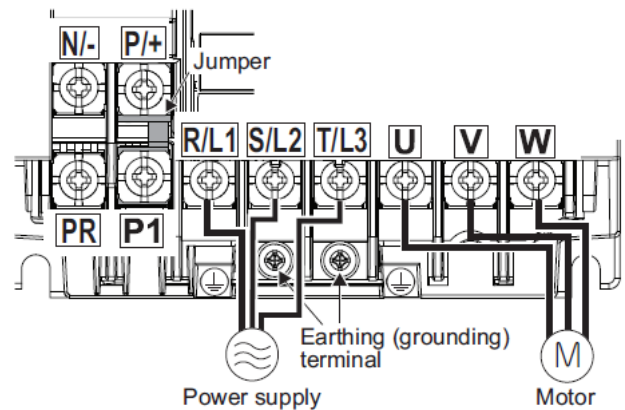

■ FR-E720-5.5K(SC) to 7.5K(SC)

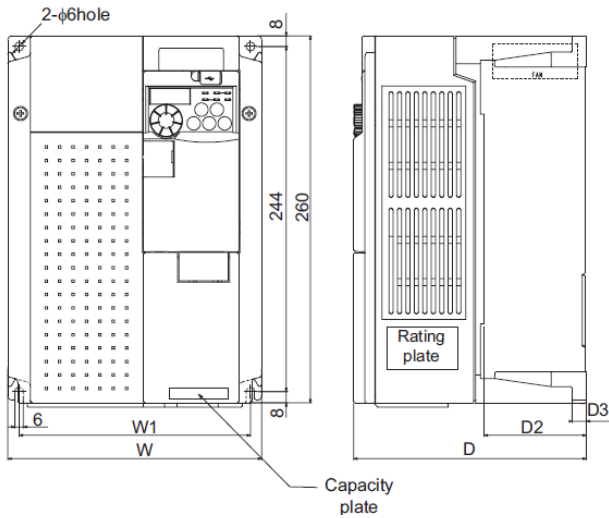

Inverter model	W	W1
FR-E720-5.5K, 7.5K	180	164
FR-E720-5.5KSC, 7.5KSC	180	164

Inverter model	D	D2	D3
FR-E720-5.5K, 7.5K	165	71.5	10
FR-E720-5.5KSC, 7.5KSC	171	71.5	10

When the plug-in option is installed, the depth required for installation is approx. 15.1 mm larger for the standard control circuit terminal model, and approx. 21.6 mm larger for the safety stop function model. *

* When the FR-A7NC (E kit) is used for the standard control circuit terminal model, or when the FR-A7NC and the FR-A7NC E kit safety cover SC are used for the safety stop function model, a terminal block protrudes forward and the depth is approx. 2 mm (up to 2.8 mm) larger.

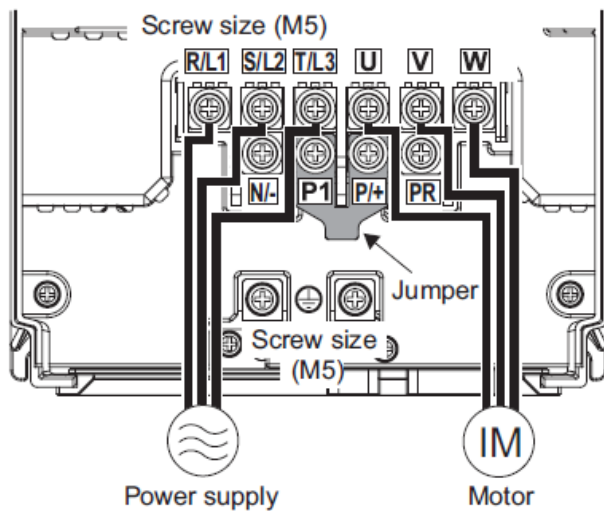

■ FR-E820-5.5K, 7.5K-1

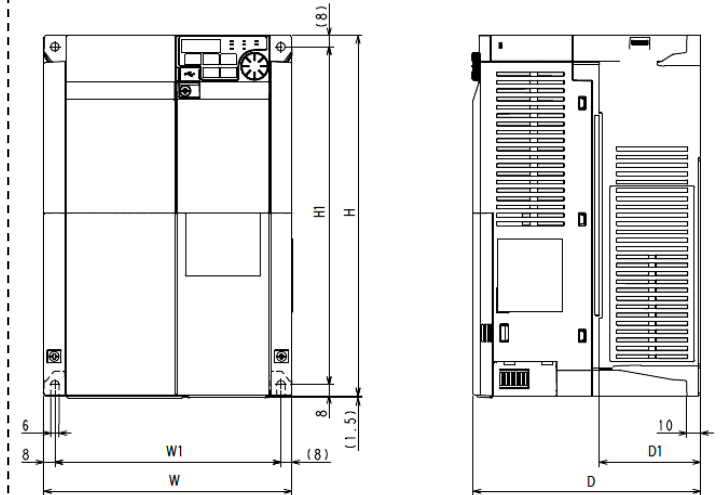

Inverter model	W	W1	H	H1	D	D1
FR-E820-5.5K, 7.5K	180	164	260	244	165	71.5

When the plug-in option is installed, the depth required for installation is approx. 27.6 mm larger.

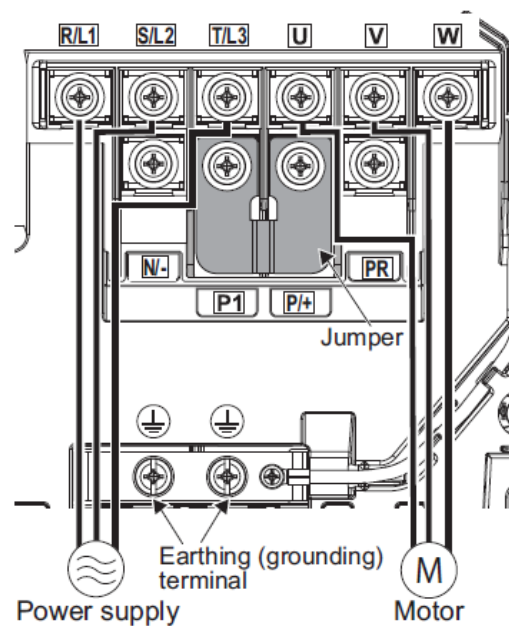

■ FR-E720-11K(SC), 15K(SC)

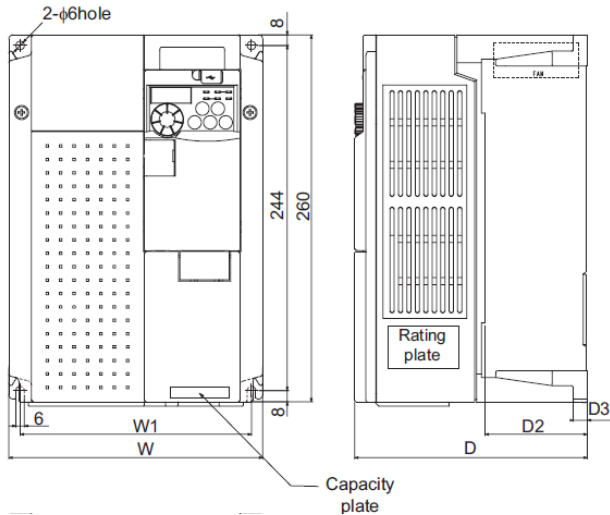

Inverter model	W	W1
FR-E720-11K, 15K	220	195
FR-E720-11K, 15KSC	220	195

Inverter model	D	D2	D3
FR-E720-11K, 15K	190	84.5	10.5
FR-E720-11K, 15KSC	196	84.5	10.5

When the plug-in option is installed, the depth required for installation is approx. 15.1 mm larger for the standard control circuit terminal model, and approx. 21.6 mm larger for the safety stop function model. *

* When the FR-A7NC (E kit) is used for the standard control circuit terminal model, or when the FR-A7NC and the FR-A7NC E kit safety cover SC are used for the safety stop function model, a terminal block protrudes forward and the depth is approx. 2 mm (up to 2.8 mm) larger.

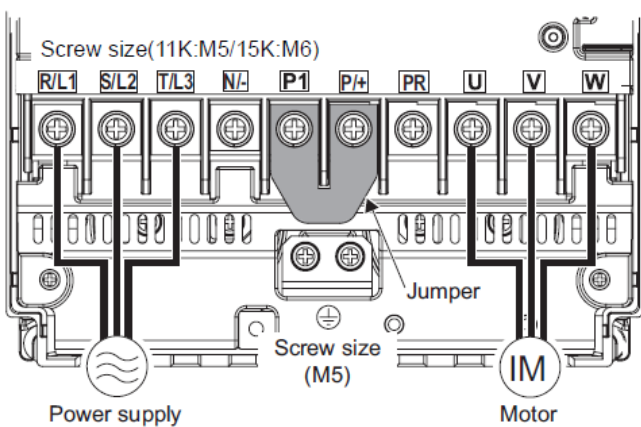

■ FR-E820-11K, 15K-1

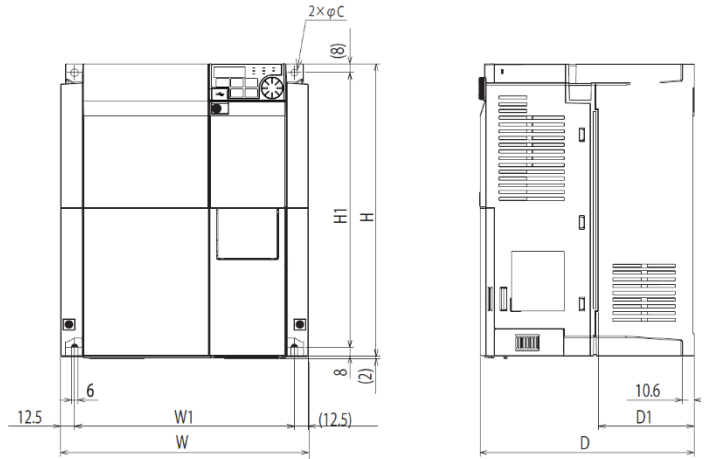

Inverter model	W	W1	H	H1	D	D1	C
FR-E820-11K, 15K	220	195	260	244	190	84.7	6

When the plug-in option is installed, the depth required for installation is approx. 27.6 mm larger.

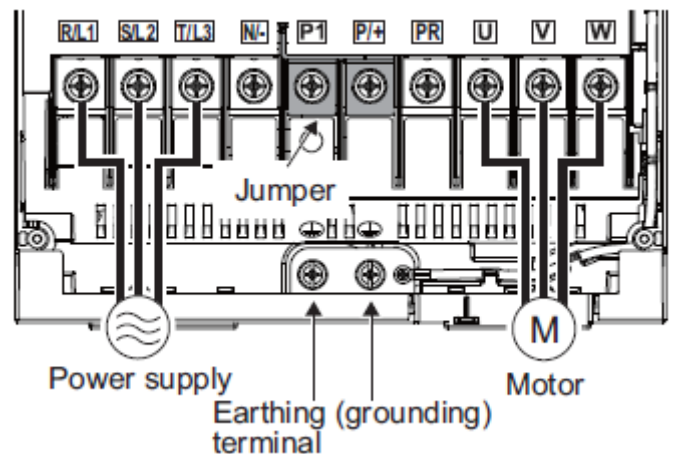

■ FR-E740-0.4K(SC) to 3.7K(SC)

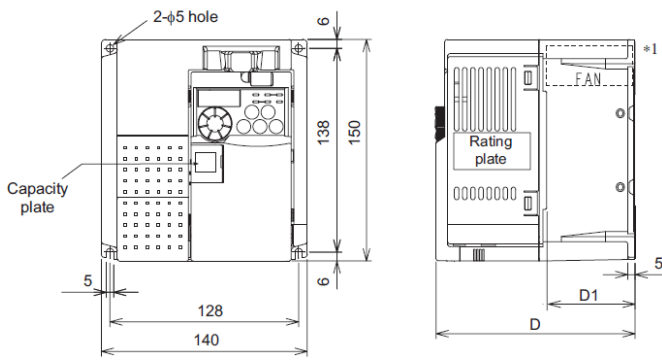

Inverter model	D	D1
FR-E740-0.4K, 0.75K	114	39
FR-E740-0.4KSC, 0.75KSC	120	39
FR-E740-1.5K, 2.2K, 3.7K	135	60
FR-E740-1.5KSC, 2.2KSC, 3.7KSC	141	60

When the plug-in option is installed, the depth required for installation is approx. 15.1 mm larger for the standard control circuit terminal model, and approx. 21.6 mm larger for the safety stop function model. *

* When the FR-A7NC (E kit) is used for the standard control circuit terminal model, or when the FR-A7NC and the FR-A7NC E kit safety cover SC are used for the safety stop function model, a terminal block protrudes forward and the depth is approx. 2 mm (up to 2.8 mm) larger.

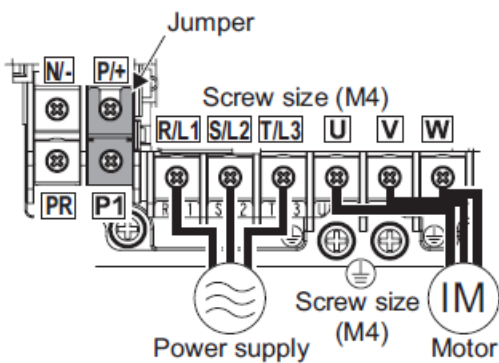

■ FR-E840-0.4K to 3.7K-1

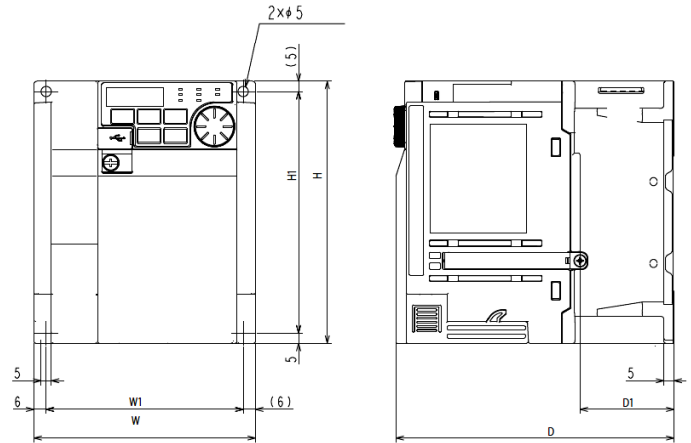

Inverter model	W	W1	H	H1	D	D1
FR-E840-0.4K, 0.75K	108	96	128	118	129.5	40
FR-E840-1.5K					135.5	46

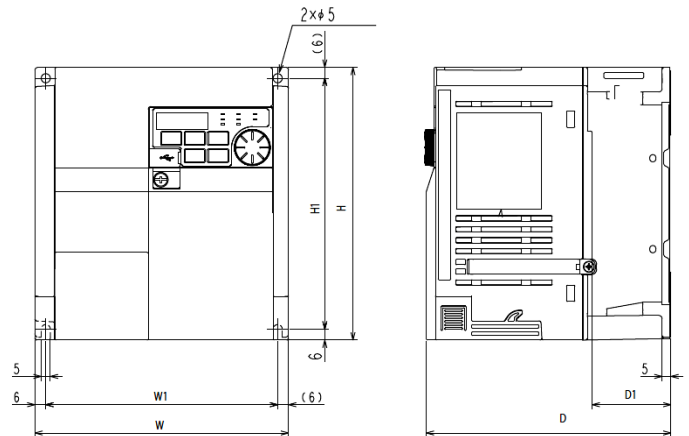

Inverter model	W	W1	H	H1	D	D1
FR-E840-2.2K, 3.7K	140	128	150	138	135	43.5

When the plug-in option is installed, the depth required for installation is approx. 27.6 mm larger.

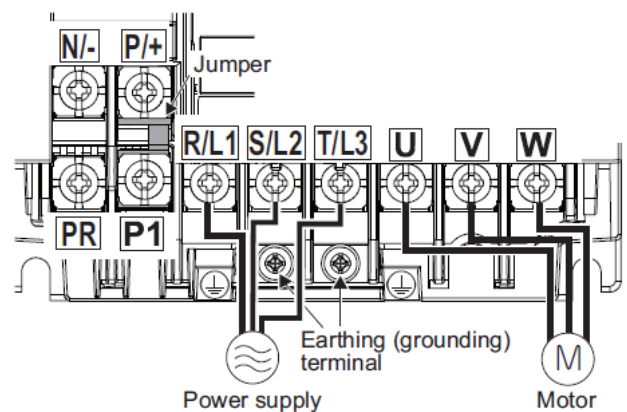

■ FR-E740-5.5K(SC), 7.5K(SC)

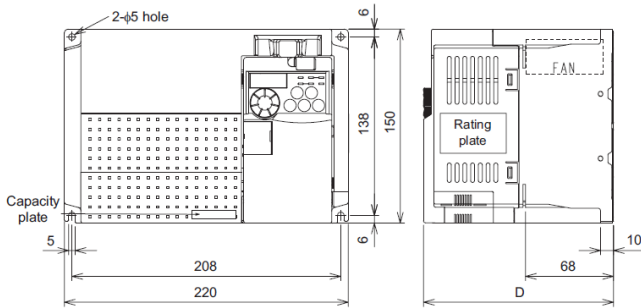

Inverter model	D
FR-E740-5.5K, 7.5K	147
FR-E740-5.5KSC, 7.5KSC	153

When the plug-in option is installed, the depth required for installation is approx. 15.1 mm larger for the standard control circuit terminal model, and approx. 21.6 mm larger for the safety stop function model. *

* When the FR-A7NC (E kit) is used for the standard control circuit terminal model, or when the FR-A7NC and the FR-A7NC E kit safety cover SC are used for the safety stop function model, a terminal block protrudes forward and the depth is approx. 2 mm (up to 2.8 mm) larger.

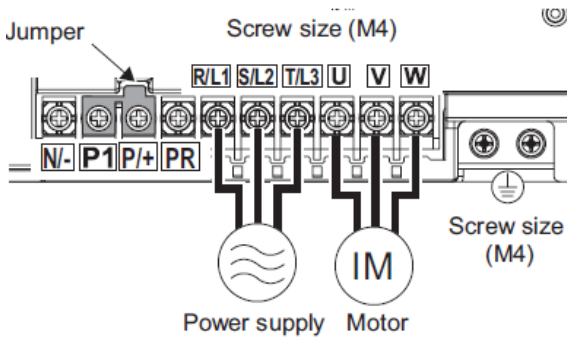

■ FR-E840-5.5K, 7.5K-1

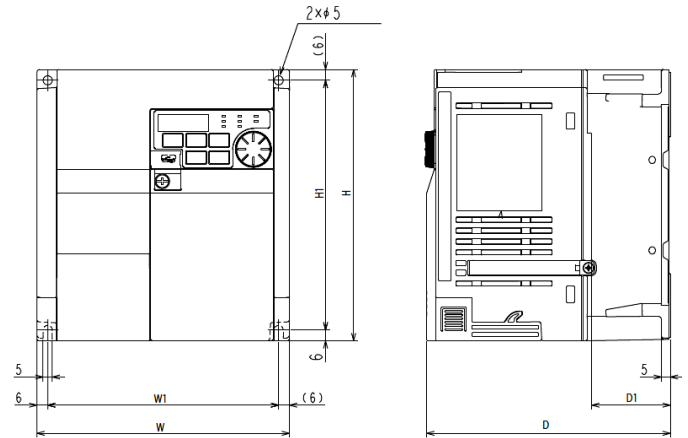

Inverter model	W	W1	H	H1	D	D1
FR-E840-5.5K, 7.5K	220	208	150	138	147	68

When the plug-in option is installed, the depth required for installation is approx. 27.6 mm larger.

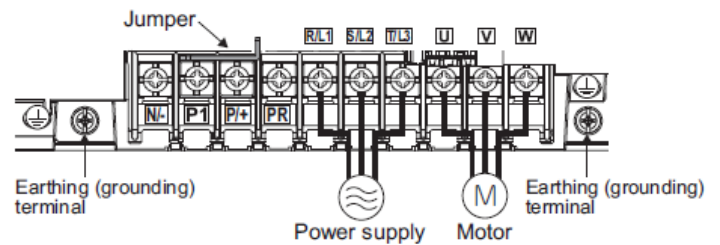

■ FR-E740-11K(SC), 15K(SC)

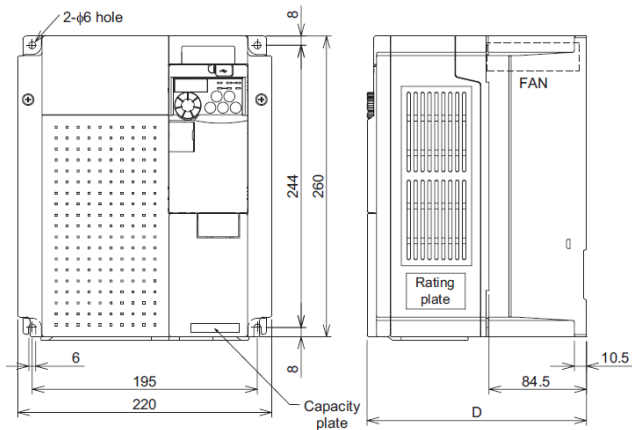

Inverter model	D
FR-E740-11K, 15K	190
FR-E740-11KSC, 15KSC	196

When the plug-in option is installed, the depth required for installation is approx. 15.1 mm larger for the standard control circuit terminal model, and approx. 21.6 mm larger for the safety stop function model. *

* When the FR-A7NC (E kit) is used for the standard control circuit terminal model, or when the FR-A7NC and the FR-A7NC E kit safety cover SC are used for the safety stop function model, a terminal block protrudes forward and the depth is approx. 2 mm (up to 2.8 mm) larger.

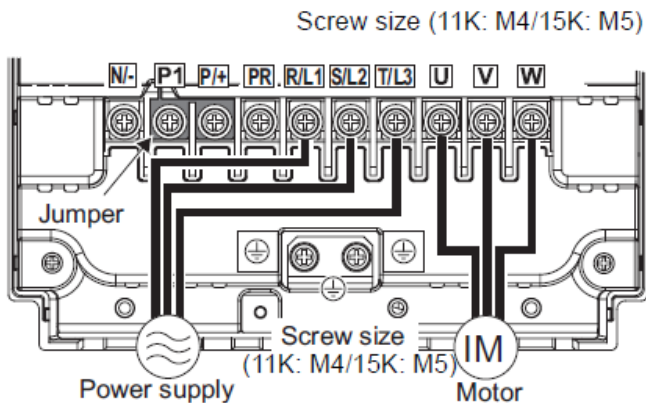

■ FR-E840-11K, 15K-1

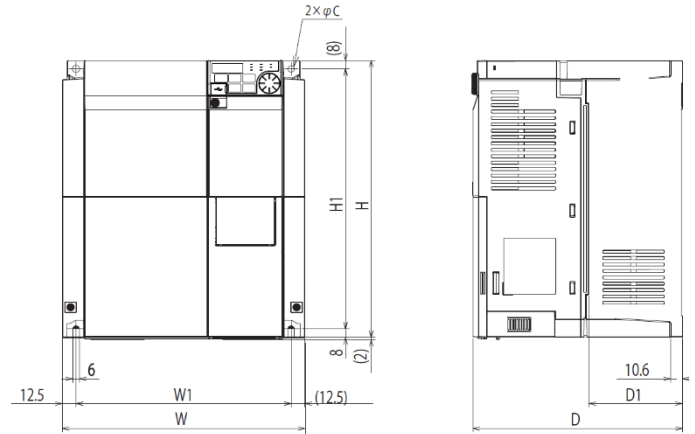

Inverter model	W	W1	H	H1	D	D1	C
FR-E840-11K, 15K	220	195	260	244	190	84.7	6

When the plug-in option is installed, the depth required for installation is approx. 27.6 mm larger.

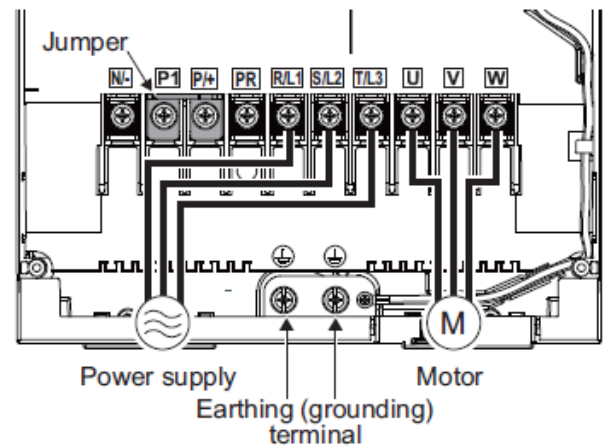

■ FR-E720S-0.1K(SC) to 0.4K(SC)

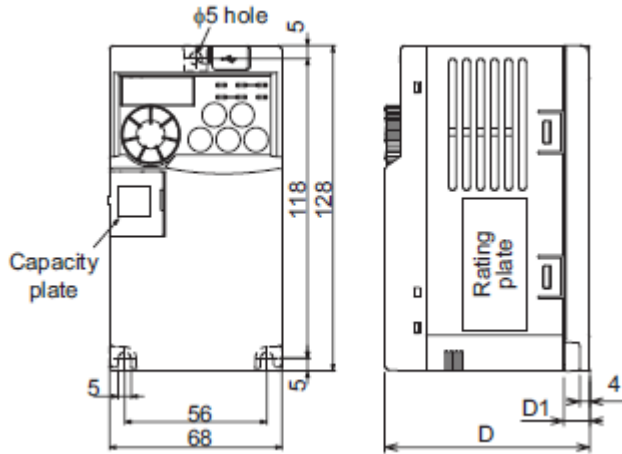

Inverter model	D	D1
FR-E720S-0.1K, 0.2K	80.5	10
FR-E720S-0.1KSC, 0.2KSC	86.5	10
FR-E720S-0.4K	142.5	42
FR-E720S-0.4KSC	148.5	42

When the plug-in option is installed, the depth required for installation is approx. 15.1 mm larger for the standard control circuit terminal model, and approx. 21.6 mm larger for the safety stop function model. *

* When the FR-A7NC (E kit) is used for the standard control circuit terminal model, or when the FR-A7NC and the FR-A7NC E kit safety cover SC are used for the safety stop function model, a terminal block protrudes forward and the depth is approx. 2 mm (up to 2.8 mm) larger.

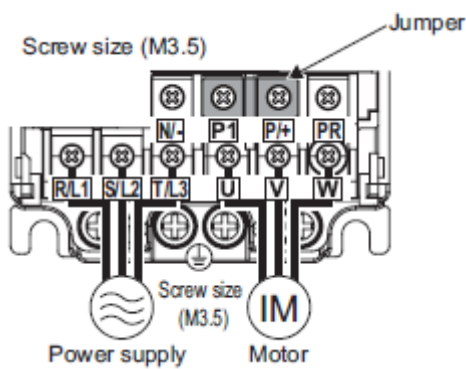

■ FR-E820S-0.1K to 0.4K-1

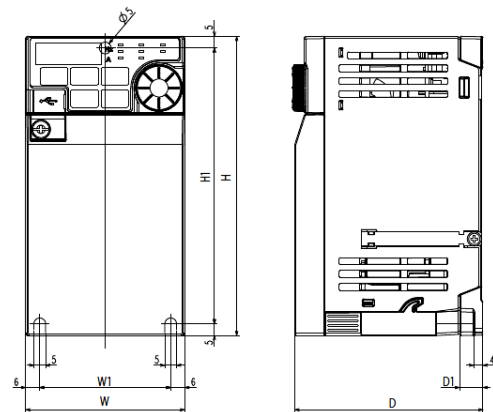

Inverter model	W	W1	H	H1	D	D1
FR-E820S-0.1K, 0.2K	68	56	128	118	80.5	10
FR-E820S-0.4K					142.5	42

When the plug-in option is installed, the depth required for installation is approx. 27.6 mm larger.

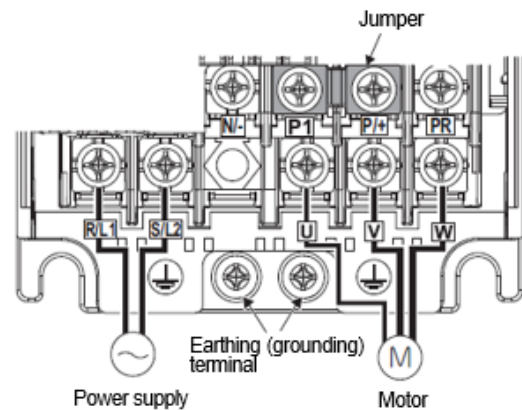

■ FR-E720S-0.75K(SC)

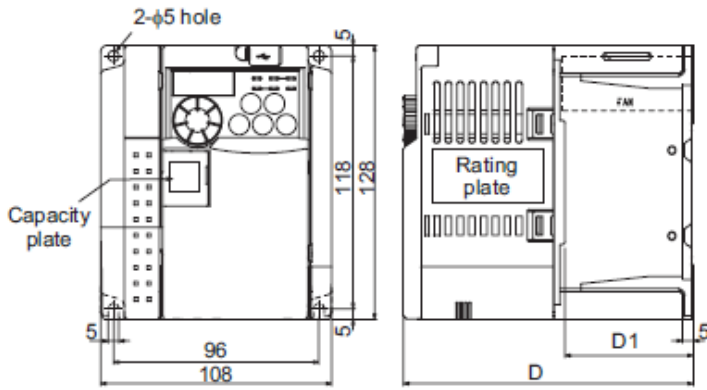

Inverter model	D	D1
FR-E720S-0.75K	135.5	60
FR-E720S-0.75KSC	141.5	60

When the plug-in option is installed, the depth required for installation is approx. 15.1 mm larger for the standard control circuit terminal model, and approx. 21.6 mm larger for the safety stop function model. *

* When the FR-A7NC (E kit) is used for the standard control circuit terminal model, or when the FR-A7NC and the FR-A7NC E kit safety cover SC are used for the safety stop function model, a terminal block protrudes forward and the depth is approx. 2 mm (up to 2.8 mm) larger.

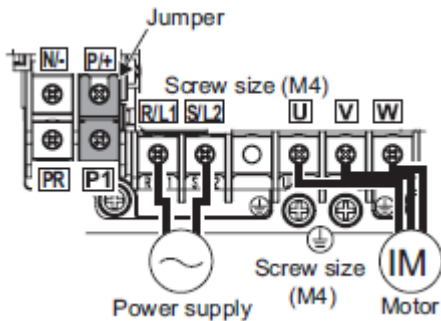

■ FR-E820S-0.75K-1

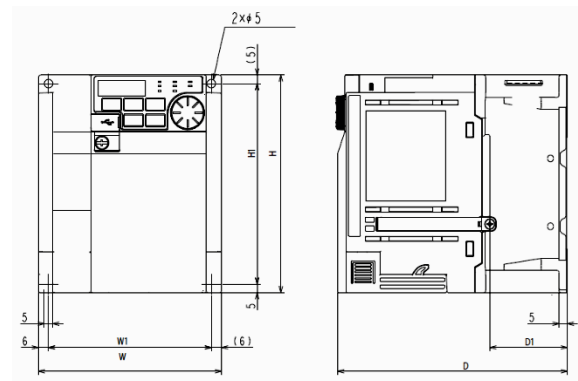

Inverter model	W	W1	H	H1	D	D1
FR-E820S-0.75K	108	96	128	118	135	45.5

When the plug-in option is installed, the depth required for installation is approx. 27.6 mm larger.

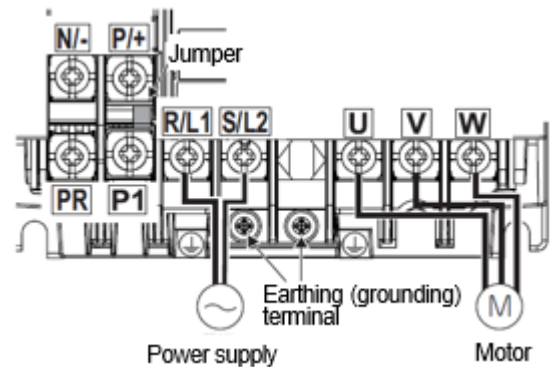

■ FR-E720S-1.5K(SC)

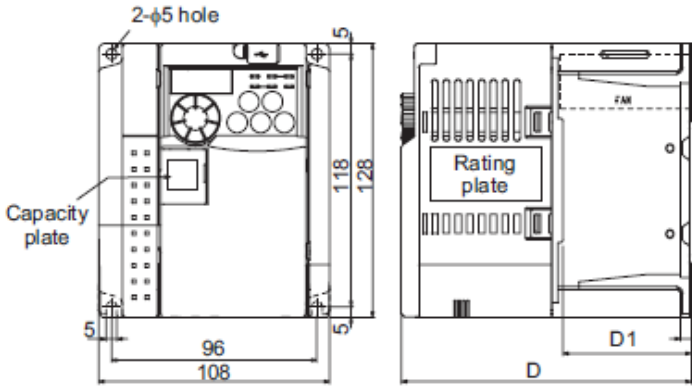

Inverter model	D	D1
FR-E720S-1.5K	161	60
FR-E720S-1.5KSC	167	60

When the plug-in option is installed, the depth required for installation is approx. 15.1 mm larger for the standard control circuit terminal model, and approx. 21.6 mm larger for the safety stop function model. *

* When the FR-A7NC (E kit) is used for the standard control circuit terminal model, or when the FR-A7NC and the FR-A7NC E kit safety cover SC are used for the safety stop function model, a terminal block protrudes forward and the depth is approx. 2 mm (up to 2.8 mm) larger.

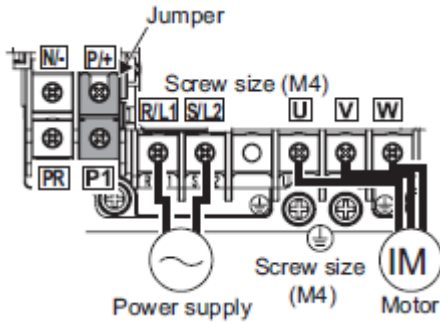

■ FR-E820S-1.5K-1

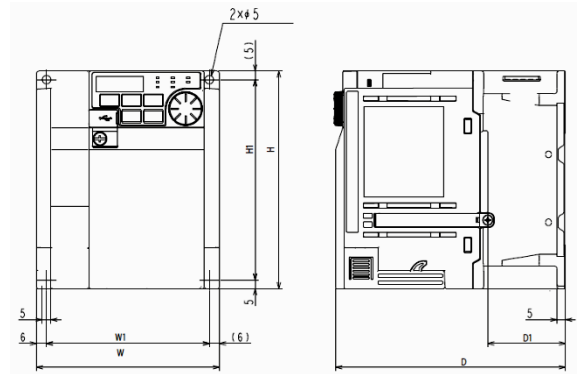

Inverter model	W	W1	H	H1	D	D1
FR-E820S-1.5K	108	96	128	118	161	46

When the plug-in option is installed, the depth required for installation is approx. 27.6 mm larger.

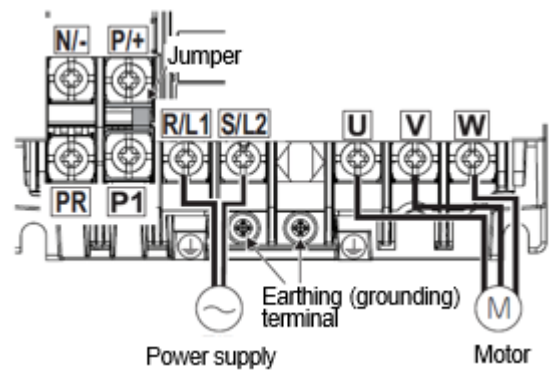

■ FR-E720S-2.2K(SC)

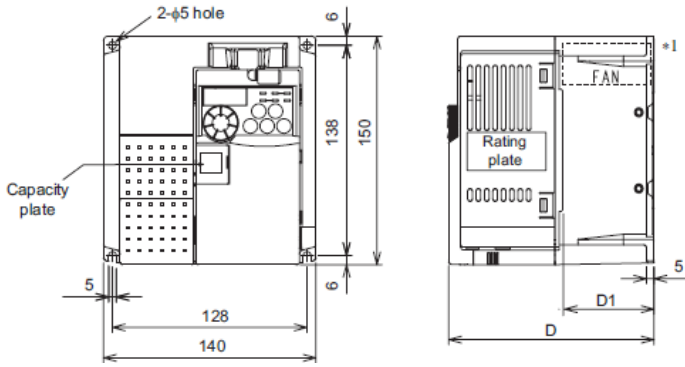

Inverter model	D	D1
FR-E720S-2.2K	155.5	60
FR-E720S-2.2KSC	161.5	60

When the plug-in option is installed, the depth required for installation is approx. 15.1 mm larger for the standard control circuit terminal model, and approx. 21.6 mm larger for the safety stop function model. *

* When the FR-A7NC (E kit) is used for the standard control circuit terminal model, or when the FR-A7NC and the FR-A7NC E kit safety cover SC are used for the safety stop function model, a terminal block protrudes forward and the depth is approx. 2 mm (up to 2.8 mm) larger.

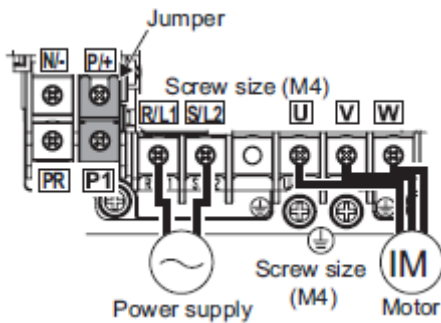

■ FR-E820S-2.2K-1

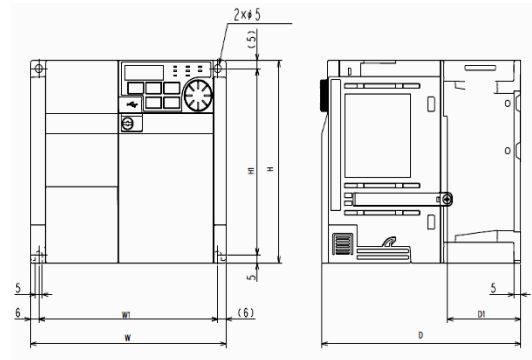

Inverter model	W	W1	H	H1	D	D1
FR-E820S-2.2K	140	128	128	118	142.5	52.5

When the plug-in option is installed, the depth required for installation is approx. 27.6 mm larger.

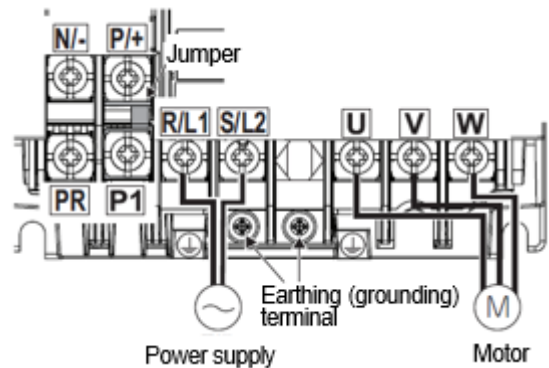

■ FR-E710W-0.1K to 0.4K

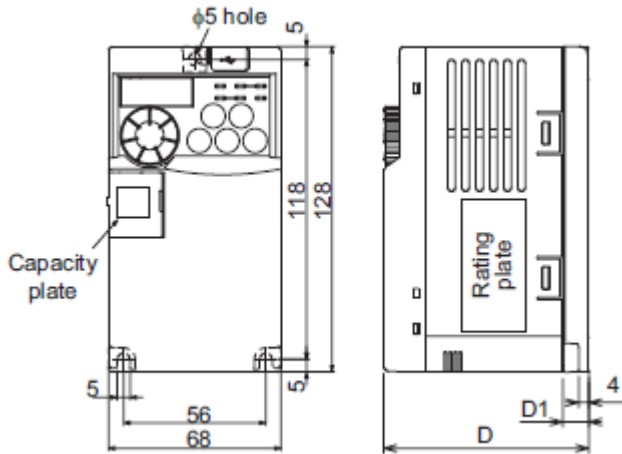

Inverter model	D	D1
FR-E710W-0.1K	80.5	10
FR-E710W-0.2K	110.5	10
FR-E710W-0.4K	142.5	42

When the plug-in option is installed, the depth required for installation is approx. 15.1 mm larger for the standard control circuit terminal model. *

* When the FR-A7NC (E kit) is used for the standard control circuit terminal model, a terminal block protrudes forward and the depth is approx. 2 mm (up to 2.8 mm) larger.

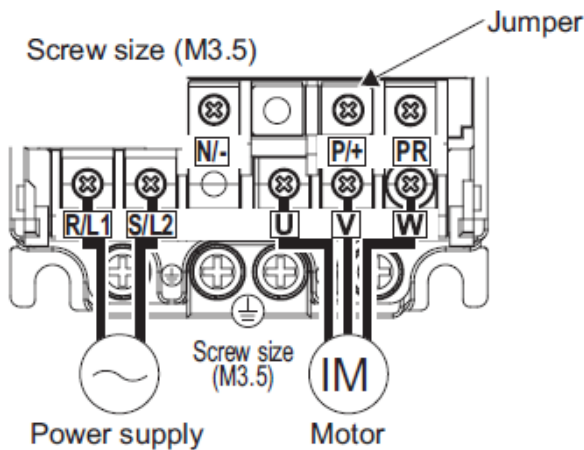

■ FR-E810W-0.1K to 0.4K-1

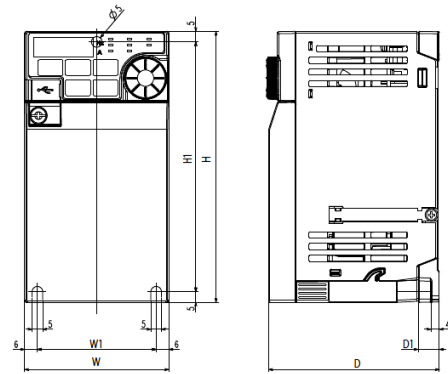

Inverter model	W	W1	H	H1	D	D1
FR-E810W-0.1K	68	56	128	118	80.5	10
FR-E810W-0.2K					110.5	10
FR-E810W-0.4K					142.5	42

When the plug-in option is installed, the depth required for installation is approx. 27.6 mm larger.

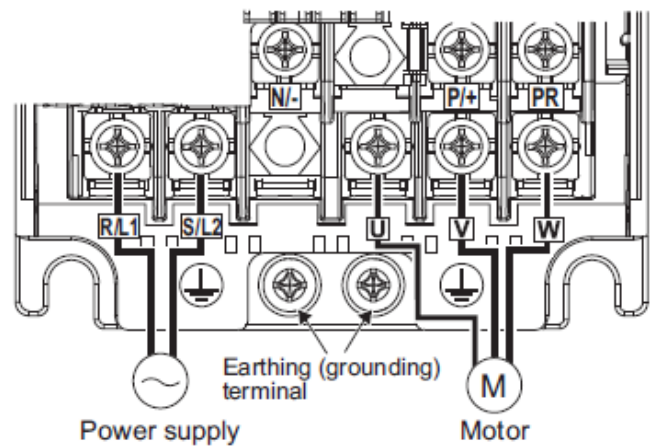

■ FR-E710W-0.75K

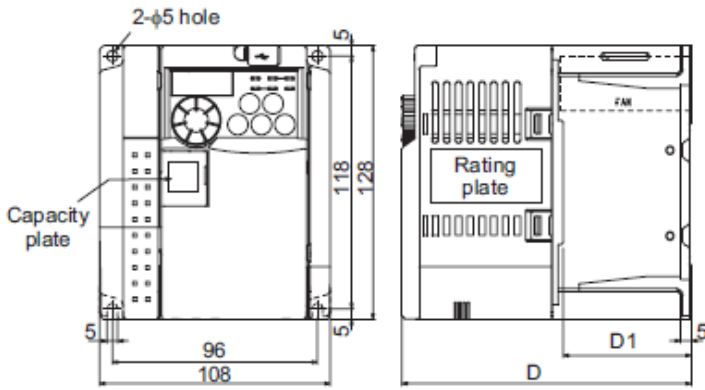

Inverter model	D	D1
FR-E710W-0.75K	155	54

When the plug-in option is installed, the depth required for installation is approx. 15.1 mm larger for the standard control circuit terminal model. *

* When the FR-A7NC (E kit) is used for the standard control circuit terminal model, a terminal block protrudes forward and the depth is approx. 2 mm (up to 2.8 mm) larger.

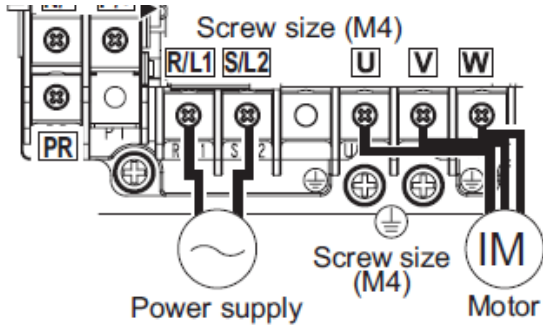

■ FR-E810W-0.75K-1

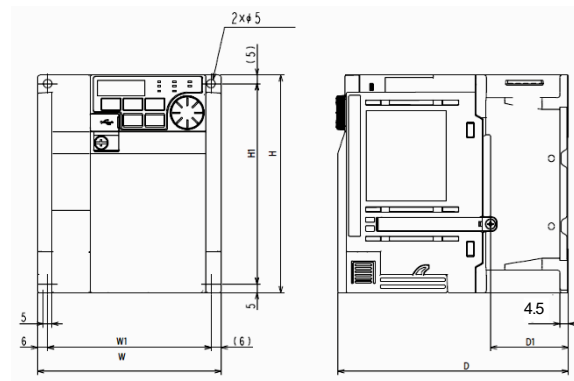

Inverter model	W	W1	H	H1	D	D1
FR-E810W-0.75K	108	96	128	118	155	40

When the plug-in option is installed, the depth required for installation is approx. 27.6 mm larger.

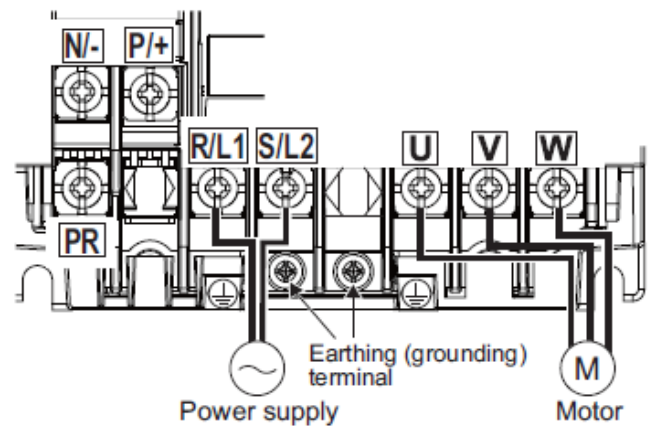

2. Wiring

The wiring of the new inverters can follow the one of the existing inverters as the terminal names between them are almost the same.

For the terminal screw size, refer to the following pages.

[Standard control circuit terminal model and safety stop function model]

Type		FR-E700 terminal name		FR-E800 compatible terminal name	Remarks
		E700-□	E700-□SC	E800-□-1	
Main circuit		R/L1, S/L2, T/L3		R/L1, S/L2, T/L3	Terminals T and T/L3 are not available for the single-phase power input model.
		U, V, W		U, V, W	
		P/+, PR		P/+, PR	
		P/+, N/-		P/+, N/-	
		P/+, P1		P/+, P1	
		⊕		⊕	
Control circuit / input signal	Contact	STF	STF	STF	
		STR	STR	STR	
		RH	RH	RH	
		RM	RM	RM	
		RL	RL	RL	
		MRS	—	MRS	
		RES	RES	RES	
		SD	SD	SD	Isolated from terminals 5 and SE.
Analog	Frequency setting	10		10	
		2		2	
		5		5	Isolated from terminals SD and SE.
		4		4	
Control circuit / output signal	Relay	A, B, C		A, B, C	
	Open collector	RUN		RUN	
		FU		FU	
		SE		SE	Isolated from terminals 5 and SD.
Pulse	FM		FM		
Safety stop function	Safety stop input	—	S1	S1	Terminal PC is a common terminal. OFF: Safety stop function is activated. ON: Safety stop function is not activated.
		—	S2	S2	
	Safety monitor output	—	—	S0	Terminal SOC is a common terminal. OFF: Internal safety circuit failure or alarm detected ON: No internal safety circuit failure
Communication	RS-485	PU connector		PU connector	Wiring methods are different. Refer to the Instruction Manual.
	USB	USB connector		USB connector	

*1 Terminal PC operates as the common terminal for safety stop input terminals, the external transistor common terminal (sink logic), the common terminal for contact input terminal (source logic), or the 24 VDC power supply terminal. To use terminal PC while the safety stop function is not used, short across terminals S1 and PC and terminals S2 and PC. Then connect terminal PC to the power supply common terminal of a transistor device, contact input terminals, or 24 VDC power supply.

Terminal screw size

[Main circuit terminal]

Voltage class	Capacity	FR-E700-□(SC)				FR-E800-□-1			
		R, S, T	U, V, W	P, N, P1, PR	⊕	R, S, T	U, V, W	P, N, P1, PR	⊕
Three-phase 200 V	0.1K to 0.75K	M3.5	M3.5	M3.5	M3.5	M3.5	M3.5	M3.5	M3.5
	1.5K to 3.7K	M4	M4	M4	M4	M4	M4	M4	M4
	5.5K, 7.5K, 11K	M5	M5	M5	M5	M5	M5	M5	M5
	15K	M6	M6	M6	M6	M6	M6	M6	M5
Three-phase 400 V	0.4K to 3.7K	M4	M4	M4	M4	M4	M4	M4	M4
	5.5K, 7.5K, 11K	M4	M4	M4	M4	M4	M4	M4	M4
	15K	M5	M5	M5	M5	M5	M5	M5	M5
Single-phase 200 V	0.1K to 0.4K	M3.5	M3.5	M3.5	M3.5	M3.5	M3.5	M3.5	M3.5
	0.75K	M4	M4	M4	M4	M4	M4	M4	M4
	1.5K, 2.2K	M4	M4	M4	M4	M4	M4	M4	M4
Single-phase 100 V	0.1K to 0.4K	M3.5	M3.5	M3.5	M3.5	M3.5	M3.5	M3.5	M3.5
	0.75K	M4	M4	M4	M4	M4	M4	M4	M4

*1 Terminal T is not available for the single-phase power input model.

[Control circuit terminal]

FR-E700-[]		FR-E700-[]SC	FR-E800-[]-1
Control circuit		Control circuit	Control circuit
Other than A, B, C	A, B, C		
M2 Insertion type Ø screw terminal	M3 Insertion type Ø screw terminal	Spring clamp terminal	Spring clamp terminal

[Terminal layout]

FR-E700-[]

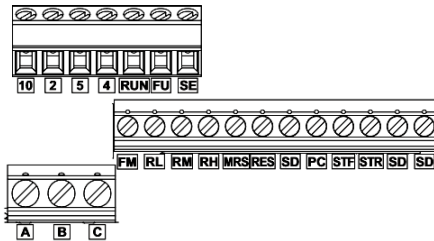

FR-E800-[]-1

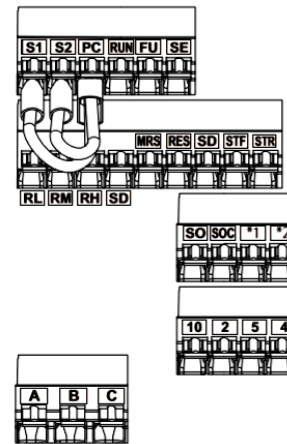

FR-E700-[]SC

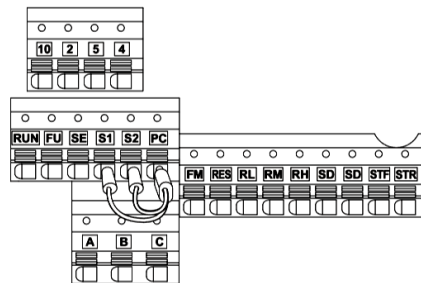

*1 Terminal FM is available for the FM type inverter.

*2 Terminal SD is available for the FM type inverter.

Note 1: When our authorized ferrules are used for the FR-E700-□ inverters, they cannot be used for the FR-E800 series inverters since they are not compatible with the spring clamp terminal block.

(Even other crimp terminals, they may not be used for the FR-E800 series inverters due to differences in size.)

To use the wires of the FR-E700-□ inverters for the FR-E800 series inverters, cut the existing crimp terminal at the end of each wire, and strip wires or use crimp terminals shown below. Check the applicable wire gauge.

Table. Applicable wire gauge (stripped wire) for the FR-E800 control terminal block

Wire strip length		Applicable stripped wire gauge
		Single wire (mm ²)
	Twist the stripped end of wires to prevent them from fraying. Do not solder it.	0.3 to 0.75

Table. Applicable wire gauge (crimped wire) for the FR-E800 control terminal block

Ferrule terminal model (Phoenix Contact Co., Ltd.)		Applicable stripped wire gauge (mm ²)
With insulation sleeve	Without insulation sleeve	
AI 0,34-10TQ	—	0.3
AI 0,5-10WH	—	0.5
AI 0,75-10GY	AI 0.75-10	0.75
AI 1-10RD	A 1-10	1
AI 1.5-10BK	AI 1.5-10	1.25, 1.5
AI-TWIN 2×0.75-GY	—	0.75 (two wires)

Blade terminal part No. (NICHIFU Co., Ltd.)		Applicable stripped wire gauge (mm ²)
Blade terminal part No.	Blade terminal part No.	
BT 0.75-11	VC 0.75	0.3 to 0.75

3. Parameter

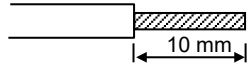
(Inverter setup software FR Configurator2 is available to automatically copy the parameter settings of the FR-E700 series to the FR-E800 series.)

Note that most parameter numbers of inverters in both series are the same but some functions differ. Refer to the following table to set the parameters.

List of FR-E800 series parameters compatible with the FR-E700(SC) series

The following table shows the parameter settings required when replacing FR-E700(SC) series inverters with FR-E800 series inverters.

When an FR-E700(SC) series parameter is set to a value other than the initial value, set the corresponding FR-E800 series parameter according to the following table.

When an FR-E700(SC) series parameter is set to an initial value, it is usually not necessary to change the corresponding FR-E800 series parameter setting.

The parameter replacement following the table below does not guarantee the inverter characteristics or performance.

The parameter number of the parameters differs from that of the FR-E700(SC) series inverter.

Setting ◎: Set the FR-E700 parameter as it is.

△: Change the FR-E700 parameter and set.

×: Adjust and set the FR-E800 inverter parameters.

FR-E700(SC) parameter list				FR-E800-[-1 compatible parameter				Parameter setting	
Pr.	Name	Setting range	Initial value	Pr.	Name	Setting range	Initial value	Setting	Remarks
0	Torque boost	0% to 30%	6% / 4% / 3% / 2%	0	Torque boost	0% to 30%	6% / 4% / 3% / 2%	△	When this parameter has been used at the initial setting in the FR-E700, change the FR-E800 setting to the value obtained by subtracting approx. 0.8% (for 200 V class) or 0.5% (for 400 V class) from the initial value. Example) When 6% is set in the FR-E720, set 5.2% in the FR-E820 according to the following formula: 6% - 0.8% = 5.2%. Adjust the setting as required.
1	Maximum frequency	0 to 120 Hz	120 Hz	1	Maximum frequency	0 to 120 Hz	120 Hz	◎	
2	Minimum frequency	0 to 120 Hz	0 Hz	2	Minimum frequency	0 to 120 Hz	0 Hz	◎	
3	Base frequency	0 to 400 Hz	60 Hz	3	Base frequency	0 to 590 Hz	60 Hz	◎	To set V/F control, set Pr.800 = "40", Pr.80 = "9999", and Pr.81 = "9999" in the FR-E800-[-1. (In the FR-E700-[(SC), Pr.80 = "9999" and Pr.81 = "9999".) The initial value of the FR-E800-[-1 is that of the parameter initial value group 1.
4	Multi-speed setting (high speed)	0 to 400 Hz	60 Hz	4	Multi-speed setting (high speed)	0 to 590 Hz	60 Hz	◎	The initial value of the FR-E800-[-1 is that of the parameter initial value group 1.
5	Multi-speed setting (middle speed)	0 to 400 Hz	30 Hz	5	Multi-speed setting (middle speed)	0 to 590 Hz	30 Hz	◎	
6	Multi-speed setting (low speed)	0 to 400 Hz	10 Hz	6	Multi-speed setting (low speed)	0 to 590 Hz	10 Hz	◎	
7	Acceleration time	0 to 3600 s / 0 to 360 s	5 s / 10 s / 15 s	7	Acceleration time	0 to 3600 s	5 s / 10 s / 15 s	◎	Changing Pr.21 after setting this parameter will change the set value. Refer to the Instruction Manual.
8	Deceleration time	0 to 3600 s / 0 to 360 s	5 s / 10 s / 15 s	8	Deceleration time	0 to 3600 s	5 s / 10 s / 15 s	◎	
9	Electronic thermal O/L relay	0 to 500 A	Rated output current	9	Electronic thermal O/L relay	0 to 500 A	Rated output current	◎	Set the rated motor current.
10	DC injection brake operation frequency	0 to 120 Hz	3 Hz	10	DC injection brake operation frequency	0 to 120 Hz	3 Hz	◎	
11	DC injection brake operation time	0 to 10 s	0.5 s	11	DC injection brake operation time	0 to 10 s, 8888	0.5 s	◎	
12	DC injection brake operation voltage	0% to 30%	6% / 4% / 2%	12	DC injection brake operation voltage	0% to 30%	6% / 4% / 2%	◎	
13	Starting frequency	0 to 60 Hz	0.5 Hz	13	Starting frequency	0 to 60 Hz	0.5 Hz	◎	
14	Load pattern selection	0 to 3	0	14	Load pattern selection	0 to 3	0	◎	
15	Jog frequency	0 to 400 Hz	5 Hz	15	Jog frequency	0 to 590 Hz	5 Hz	◎	For JOG operation, the JOG signal (input via a control circuit terminal) and the JOG2 signal (input via a control circuit terminal or via communication) are provided.
16	Jog acceleration/deceleration time	0 to 3600 s / 0 to 360 s	0.5 s	16	Jog acceleration/deceleration time	0 to 3600 s	0.5 s	◎	Changing Pr.21 after setting this parameter will change the set value. Refer to the Instruction Manual.
17	MRS input selection	0, 2, 4	0	17	MRS/X10 terminal input selection	0 to 5	0	◎	The input specification of the X10 signal can be changed.

FR-E700(SC) parameter list				FR-E800-[-]1 compatible parameter				Parameter setting	
Pr.	Name	Setting range	Initial value	Pr.	Name	Setting range	Initial value	Setting	Remarks
18	High speed maximum frequency	120 to 400 Hz	120 Hz	18	High speed maximum frequency	0 to 590 Hz	120 Hz	⊙	
19	Base frequency voltage	0 to 1000 V, 8888, 9999	9999	19	Base frequency voltage	0 to 1000 V, 8888, 9999	9999	⊙	To set V/F control, set Pr.800 = "40", Pr.80 = "9999", and Pr.81 = "9999" in the FR-E800-[-]1. (In the FR-E700-[-](SC), Pr.80 = "9999" and Pr.81 = "9999".) The initial value of the FR-E800-[-]1 is that of the parameter initial value group 1.
20	Acceleration/deceleration reference frequency	1 to 400 Hz	60 Hz	20	Acceleration/deceleration reference frequency	1 to 590 Hz	60 Hz	⊙	The initial value of the FR-E800-[-]1 is that of the parameter initial value group 1.
21	Acceleration/deceleration time increments	0, 1	0	21	Acceleration/deceleration time increments	0, 1	0	△	Changing Pr.21 after setting this parameter will change the set value. Refer to the Instruction Manual.
22	Stall prevention operation level	0% to 200%	150%	22	Stall prevention operation level (torque limit level)	0% to 400%	150%	⊙	Set Pr.570 = "2" to select ND rating.
23	Stall prevention operation level compensation factor at double speed	0% to 200%, 9999	9999	23	Stall prevention operation level compensation factor at double speed	0% to 200%, 9999	9999	⊙	
24	Multi-speed setting (speed 4)	0 to 400 Hz, 9999	9999	24	Multi-speed setting (speed 4)	0 to 590 Hz, 9999	9999	⊙	
25	Multi-speed setting (speed 5)	0 to 400 Hz, 9999	9999	25	Multi-speed setting (speed 5)	0 to 590 Hz, 9999	9999	⊙	
26	Multi-speed setting (speed 6)	0 to 400 Hz, 9999	9999	26	Multi-speed setting (speed 6)	0 to 590 Hz, 9999	9999	⊙	
27	Multi-speed setting (speed 7)	0 to 400 Hz, 9999	9999	27	Multi-speed setting (speed 7)	0 to 590 Hz, 9999	9999	⊙	
29	Acceleration/deceleration pattern selection	0, 1, 2	0	29	Acceleration/deceleration pattern selection	0, 1, 2	0	⊙	
30	Regenerative function selection	0, 1, 2	0	30	Regenerative function selection	0, 1, 2	0	⊙	
31	Frequency jump 1A	0 to 400 Hz, 9999	9999	31	Frequency jump 1A	0 to 590 Hz, 9999	9999	⊙	
32	Frequency jump 1B	0 to 400 Hz, 9999	9999	32	Frequency jump 1B	0 to 590 Hz, 9999	9999	⊙	
33	Frequency jump 2A	0 to 400 Hz, 9999	9999	33	Frequency jump 2A	0 to 590 Hz, 9999	9999	⊙	
34	Frequency jump 2B	0 to 400 Hz, 9999	9999	34	Frequency jump 2B	0 to 590 Hz, 9999	9999	⊙	
35	Frequency jump 3A	0 to 400 Hz, 9999	9999	35	Frequency jump 3A	0 to 590 Hz, 9999	9999	⊙	
36	Frequency jump 3B	0 to 400 Hz, 9999	9999	36	Frequency jump 3B	0 to 590 Hz, 9999	9999	⊙	
37	Speed display	0, 0.01 to 9998	0	37	Speed display	0.01 to 9998*	1800	△	To display the frequency, set Pr.53 = "0". To display the machine speed, set Pr.53 = "4". For the reference frequency, 60 Hz is set in Pr.505.
40	RUN key rotation direction selection	0, 1	0	40	RUN key rotation direction selection	0, 1	0	⊙	
41	Up-to-frequency sensitivity	0% to 100%	10%	41	Up-to-frequency sensitivity	0% to 100%	10%	⊙	
42	Output frequency detection	0 to 400 Hz	6 Hz	42	Output frequency detection	0 to 590 Hz	6 Hz	⊙	
43	Output frequency detection for reverse rotation	0 to 400 Hz, 9999	9999	43	Output frequency detection for reverse rotation	0 to 590 Hz, 9999	9999	⊙	
44	Second acceleration/deceleration time	0 to 3600 s / 0 to 360 s	5 s / 10 s / 15 s	44	Second acceleration/deceleration time	0 to 3600 s	5 s / 10 s / 15 s	⊙	Changing Pr.21 after setting this parameter will change the set value. Refer to the Instruction Manual.
45	Second deceleration time	0 to 3600 s / 0 to 360 s, 9999	9999	45	Second deceleration time	0 to 3600 s, 9999	9999	⊙	
46	Second torque boost	0% to 30%, 9999	9999	46	Second torque boost	0% to 30%, 9999	9999	△	Set the parameter in the same way as Pr.0.
47	Second V/F (base frequency)	0 to 400 Hz, 9999	9999	47	Second V/F (base frequency)	0 to 590 Hz, 9999	9999	⊙	To set V/F control, set Pr.800 = "40", Pr.80 = "9999", and Pr.81 = "9999" in the FR-E800-[-]1. (In the FR-E700-[-](SC), Pr.80 = "9999" and Pr.81 = "9999".)
48	Second stall prevention operation current	0% to 200%, 9999	9999	48	Second stall prevention operation level	0% to 400%, 9999	9999	⊙	
51	Second electronic thermal O/L relay	0 to 500 A, 9999	9999	51	Second electronic thermal O/L relay	0 to 500 A, 9999	9999	⊙	

* The setting ranges of Pr.1 (Pr.18), Pr.37, and Pr.505 are limited so that the following formula is satisfied.

$$\text{Pr.1 (Pr.18)} \times \text{Pr.37} / \text{Pr.505} < 8388.607$$

The setting range of Pr.1 (Pr.18) is not limited when the machine speed display is not selected. To display the machine speed, set values which satisfy the formula. For details, refer to the Instruction Manual.

FR-E700(SC) parameter list				FR-E800-[-]1 compatible parameter				Parameter setting	
Pr.	Name	Setting range	Initial value	Pr.	Name	Setting range	Initial value	Setting	Remarks
52	DU/PU main display data selection	0, 5, 7 to 12, 14, 20, 23 to 25, 52 to 57, 61, 62, 100	0	52	Operation panel main monitor selection	0, 5 to 14, 17 to 20, 22 to 33, 35, 38, 40 to 42, 44, 45, 50 to 57, 61, 62, 64, 65, 67, 68, 71, 72, 81 to 84, 85, 91, 97, 100	0	⊙	
—				53	Frequency / rotation speed unit switchover	0, 1, 4	0	△	
54	FM terminal function selection	1 to 3, 5, 7 to 12, 14, 21, 24, 52, 53, 61, 62	1	54	FM terminal function selection	1 to 3, 5 to 14, 17, 18, 21, 24, 32, 33, 50, 52, 53, 61, 62, 65, 67, 70, 85, 97	1	⊙	
55	Frequency monitoring reference	0 to 400 Hz	60 Hz	55	Frequency monitoring reference	0 to 590 Hz	60 Hz	⊙	The initial value of the FR-E800-[-]1 is that of the parameter initial value group 1.
56	Current monitoring reference	0 to 500 A	Rated output current	56	Current monitoring reference	0 to 500 A	Rated output current	⊙	
57	Restart coasting time	0, 0.1 to 5 s, 9999	9999	57	Restart coasting time	0, 0.1 to 30 s, 9999	9999	⊙	
58	Restart cushion time	0 to 60 s	1.0 s	58	Restart cushion time	0 to 60 s	1.0 s	⊙	
59	Remote function selection	0, 1, 2, 3	0	59	Remote function selection	0 to 3, 11 to 13	0	⊙	The inverter can decelerate the motor to the frequency lower than the set frequency by the remote setting function.
60	Energy saving control selection	0, 9	0	60	Energy saving control selection	0, 9	0	⊙	
61	Reference current	0 to 500 A, 9999	9999	61	Reference current	0 to 500 A, 9999	9999	⊙	
62	Reference value at acceleration	0% to 200%, 9999	9999	62	Reference value at acceleration	0% to 400%, 9999	9999	⊙	
63	Reference value at deceleration	0% to 200%, 9999	9999	63	Reference value at deceleration	0% to 400%, 9999	9999	⊙	
65	Retry selection	0 to 5	0	65	Retry selection	0 to 5	0	△	When an error that triggers the retry operation occurs, the retry operation continues even when another error that does not trigger a retry. After the retry due to the former error is complete, the retry operation is stopped due to the latter error.
66	Stall prevention operation reduction starting frequency	0 to 400 Hz	60 Hz	66	Stall prevention operation reduction starting frequency	0 to 590 Hz	60 Hz	⊙	The initial value of the FR-E800-[-]1 is that of the parameter initial value group 1.
67	Number of retries at fault occurrence	0 to 10, 101 to 110	0	67	Number of retries at fault occurrence	0 to 10, 101 to 110	0	⊙	
68	Retry waiting time	0.1 to 360 s	1 s	68	Retry waiting time	0.1 to 600 s	1 s	⊙	
69	Retry count display erase	0	0	69	Retry count display erase	0	0	⊙	
70	Special regenerative brake duty	0% to 30%	0%	70	Special regenerative brake duty	0% to 100%	0%	⊙	
71	Applied motor	0, 1, 3 to 6, 13 to 16, 23, 24, 40, 43, 44, 50, 53, 54	0	71	Applied motor	0, 3, 5, 6, 10, 13, 15, 16, 20, 23, 30, 33, 40, 43, 50, 53, 70, 73, 540, 1140, 1800, 1803, 8090, 8093, 9090, 9093	0	△	Change the setting value as follows: FR-E700 → FR-E800 1 or 14 → 10 or 13. 4, 23, or 24 → 0 or 3. 44 → 40 or 43. 54 → 50 or 53.
72	PWM frequency selection	0 to 15	1	72	PWM frequency selection	0 to 15	1	△	Change the Pr.260 setting as required.
73	Analog input selection	0, 1, 10, 11	1	73	Analog input selection	0, 1, 6, 10, 11, 16	1	△	Use the voltage/current input selection switch 2 or 4 to select voltage input or current input.
74	Input filter time constant	0 to 8	1	74	Input filter time constant	0 to 8	1	⊙	
75	Reset selection/disconnected PU detection/PU stop selection	0 to 3, 14 to 17	14	75	Reset selection/disconnected PU detection/PU stop selection	0 to 3, 14 to 17	14	⊙	
77	Parameter write selection	0, 1, 2	0	77	Parameter write selection	0, 1, 2	0	⊙	
78	Reverse rotation prevention selection	0, 1, 2	0	78	Reverse rotation prevention selection	0, 1, 2	0	⊙	
79	Operation mode selection	0 to 4, 6, 7	0	79	Operation mode selection	0 to 4, 6, 7	0	⊙	

FR-E700(SC) parameter list				FR-E800-[-]1 compatible parameter				Parameter setting	
Pr.	Name	Setting range	Initial value	Pr.	Name	Setting range	Initial value	Setting	Remarks
80	Motor capacity	0.1 to 15 kW, 9999	9999	80	Motor capacity	0.1 to 30 kW, 9999	9999	△	To set V/F control, set Pr.800 = "40". To set other control mode, change the setting values in Pr.80 and Pr.81. When the operation is started under a control mode other than V/F control while "9999" is set in Pr.80 and Pr.81, SE alarm is displayed. (Example) Pr.800 = "20", Pr.80 and Pr.81 = "9999".
81	Number of motor poles	2, 4, 6, 8, 10, 9999	9999	81	Number of motor poles	2, 4, 6, 8, 10, 12, 9999	9999	△	
82	Motor excitation current	0 to 500 A, 9999	9999	82	Motor excitation current	0 to 500 A, 9999	9999	⊙	
83	Rated motor voltage	0 to 1000 V	200/400 V	83	Rated motor voltage	0 to 1000 V	200/400 V	⊙	
84	Rated motor frequency	10 to 120 Hz	60 Hz	84	Rated motor frequency	10 to 400 Hz, 9999	9999	△	When "9999" is set, the setting value of Pr.3 is used.
89	Speed control gain (Advanced magnetic flux vector)	0% to 200%, 9999	9999	89	Speed control gain (Advanced magnetic flux vector)	0% to 200%, 9999	9999	⊙	
90	Motor constant (R1)	0 to 50 Ω, 9999	9999	90	Motor constant (R1)	0 to 50 Ω, 9999	9999	⊙	
91	Motor constant (R2)	0 to 50 Ω, 9999	9999	91	Motor constant (R2)	0 to 50 Ω, 9999	9999	⊙	
92	Motor constant (L1)	0 to 1000 mH, 9999	9999	92	Motor constant (L1)	0 to 6000 mH, 9999	9999	⊙	
93	Motor constant (L2)	0 to 1000 mH, 9999	9999	93	Motor constant (L2)	0 to 6000 mH, 9999	9999	⊙	
94	Motor constant (X)	0% to 100%, 9999	9999	94	Motor constant (X)	0% to 100%, 9999	9999	⊙	
96	Auto tuning setting/status	0, 1, 11, 21	0	96	Auto tuning setting/status	0, 1, 11	0	△	Change the setting value as follows: FR-E700 → FR-E800 1 or 11 → 1. 21 → 11. If auto tuning has been performed, perform tuning again as required.
117	PU communication station number	0 to 31 (0 to 247)	0	117	PU communication station number	0 to 31 (0 to 247)	0	⊙	Available in FR-E800-[-]1. For the communication speed of MODBUS RTU communication, the initial value is changed from "96" to "192". For communication parity check, set Pr.119 as required.
118	PU communication speed	48, 96, 192, 384	192 (96)	118	PU communication speed	48, 96, 192, 384, 576, 768, 1152	192	⊙	
119	PU communication stop bit length	0, 1, 10, 11	1	119	PU communication stop bit length	0, 1, 10, 11	1	⊙	
120	PU communication parity check	0, 1, 2	2	120	PU communication parity check	0, 1, 2	2	⊙	
121	Number of PU communication retries	0 to 10, 9999	1	121	PU communication retry count	0 to 10, 9999	1	⊙	
122	PU communication check time interval	0, 0.1 to 999.8 s, 9999	0	122	PU communication check time interval	0, 0.1 to 999.8 s, 9999	0	⊙	
123	PU communication waiting time setting	0 to 150 ms, 9999	9999	123	PU communication waiting time setting	0 to 150 ms, 9999	9999	⊙	
124	PU communication CR/LF selection	0, 1, 2	1	124	PU communication CR/LF selection	0, 1, 2	1	⊙	
125	Terminal 2 frequency setting gain frequency	0 to 400 Hz	60 Hz	125	Terminal 2 frequency setting gain frequency	0 to 590 Hz	60 Hz	⊙	The initial value of the FR-E800-[-]1 is that of the parameter initial value group 1.
126	Terminal 4 frequency setting gain frequency	0 to 400 Hz	60 Hz	126	Terminal 4 frequency setting gain frequency	0 to 590 Hz	60 Hz	⊙	The initial value of the FR-E800-[-]1 is that of the parameter initial value group 1.
127	PID control automatic switchover frequency	0 to 400 Hz, 9999	9999	127	PID control automatic switchover frequency	0 to 590 Hz, 9999	9999	⊙	
128	PID action selection	0, 20, 21, 40 to 43, 50, 51, 60, 61	0	128	PID action selection	0, 20, 21, 40 to 43, 50, 51, 60, 61, 1000, 1001, 1010, 1011, 2000, 2001, 2010, 2011	0	×	The deviation value, measured value, and set point cannot be input via LONWORKS communication. Set Pr.609 and Pr.610 as required.
129	PID proportional band	0.1% to 1000%, 9999	100%	129	PID proportional band	0.1% to 1000%, 9999	100%	⊙	
130	PID integral time	0.1 to 3600 s, 9999	1 s	130	PID integral time	0.1 to 3600 s, 9999	1 s	⊙	
131	PID upper limit	0% to 100%, 9999	9999	131	PID upper limit	0% to 100%, 9999	9999	⊙	
132	PID lower limit	0% to 100%, 9999	9999	132	PID lower limit	0% to 100%, 9999	9999	⊙	
133	PID action set point	0% to 100%, 9999	9999	133	PID action set point	0% to 100%, 9999	9999	△	When "9999" is set, the set point is set by Pr.128 in the FR-E800. (In the FR-E700, terminal 2 input is the set point.) Under dancer control, the set point is input by terminal selected by Pr.609 in the FR-E800. (In the FR-E700, the set point is fixed to 50%.)

FR-E700(SC) parameter list				FR-E800-[-]1 compatible parameter				Parameter setting	
Pr.	Name	Setting range	Initial value	Pr.	Name	Setting range	Initial value	Setting	Remarks
134	PID differential time	0.01 to 10.00 s, 9999	9999	134	PID differential time	0.01 to 10.00 s, 9999	9999	⊙	
145	PU display language selection	0 to 7	0	145	PU display language selection	0 to 7	—	×	FR-PU07
146	Built-in potentiometer switching	0, 1	1	—				×	Operation panel for the FR-E500 (FR-PA02) cannot be used.
147	Acceleration/deceleration time switching frequency	0 to 400 Hz, 9999	9999	147	Acceleration/deceleration time switching frequency	0 to 590 Hz, 9999	9999	⊙	
150	Output current detection level	0% to 200%	150%	150	Output current detection level	0% to 400%	150%	⊙	Set Pr.570 = "2" to select ND rating.
151	Output current detection signal delay time	0 to 10 s	0	151	Output current detection signal delay time	0 to 10 s	0	⊙	
152	Zero current detection level	0% to 200%	5.0%	152	Zero current detection level	0% to 400%	5.0%	⊙	
153	Zero current detection time	0 to 1 s	0.5 s	153	Zero current detection time	0 to 10 s	0.5 s	⊙	
154	Voltage reduction selection during stall prevention operation selection	1, 11	1	154	Voltage reduction selection during stall prevention operation	1, 11	1	⊙	
156	Stall prevention operation selection	0 to 31, 100, 101	0	156	Stall prevention operation selection	0 to 31, 100, 101	0	⊙	
157	OL signal output timer	0 to 25 s, 9999	0	157	OL signal output timer	0 to 25 s, 9999	0	⊙	
160	User group read selection	0, 1, 9999	0	160	User group read selection	0, 1, 9999	0	⊙	
161	Frequency setting / key lock operation selection	0, 1, 10, 11	0	161	Frequency setting / key lock operation selection	0, 1, 10, 11	0	⊙	
162	Automatic restart after instantaneous power failure selection	0, 1, 10, 11	1	162	Automatic restart after instantaneous power failure selection	0, 1, 10, 11	0	△	The initial value of FR-E800 is "0".
165	Stall prevention operation level for restart	0% to 200%	150	165	Stall prevention operation level for restart	0% to 400%	150	⊙	Set Pr.570 = "2" to select ND rating.
170	Watt-hour meter clear	0, 10, 9999	9999	170	Watt-hour meter clear	0, 10, 9999	9999	⊙	
171	Operation hour meter clear	0, 9999	9999	171	Operation hour meter clear	0, 9999	9999	⊙	
172	User group registered display/batch clear	9999, (0 to 16)	0	172	User group registered display/batch clear	9999, (0 to 16)	0	⊙	
173	User group registration	0 to 999, 9999	9999	173	User group registration	0 to 1999, 9999	9999	⊙	
174	User group clear	0 to 999, 9999	9999	174	User group clear	0 to 1999, 9999	9999	⊙	
178	STF terminal function selection	0 to 5, 7, 8, 10, 12, 14 to 16, 18, 24, 25, 60, 62, 65 to 67, 9999	60	178	STF terminal function selection	0 to 5, 7, 8, 10, 12 to 16, 18, 22 to 27, 30, 37, 42, 43, 46, 47, 50, 51, 60, 62, 65 to 67, 72, 74, 76, 84, 87 to 89, 92, 9999	60	⊙	
179	STR terminal function selection	0 to 5, 7, 8, 10, 12, 14 to 16, 18, 24, 25, 61, 62, 65 to 67, 9999	61	179	STR terminal function selection	0 to 5, 7, 8, 10, 12 to 16, 18, 22 to 27, 30, 37, 42, 43, 46, 47, 50, 51, 61, 62, 65 to 67, 72, 74, 76, 84, 87 to 89, 92, 9999	61	⊙	
180	RL terminal function selection	0 to 5, 7, 8, 10, 12, 14 to 16, 18, 24, 25, 62, 65 to 67, 9999	0	180	RL terminal function selection	0 to 5, 7, 8, 10, 12 to 16, 18, 22 to 27, 30, 37, 42, 43, 46, 47, 50, 51, 62, 65 to 67, 72, 74, 76, 84, 87 to 89, 92, 9999	0	⊙	
181	RM terminal function selection		1	181	RM terminal function selection		1	⊙	
182	RH terminal function selection		2	182	RH terminal function selection		2	⊙	
183	MRS terminal function selection		24	183	MRS terminal function selection		24	⊙	
184	RES terminal function selection		62	184	RES terminal function selection		62	⊙	

FR-E700(SC) parameter list				FR-E800-[-]1 compatible parameter				Parameter setting	
Pr.	Name	Setting range	Initial value	Pr.	Name	Setting range	Initial value	Setting	Remarks
190	RUN terminal function selection	0, 1, 3, 4, 7, 8, 11 to 16, 20, 25, 26, 46, 47, 64, 68, 80, 81, 90, 91, 93, 95, 96, 98, 99, 100, 101, 103, 104, 107, 108, 111 to 116, 120, 125, 126, 146, 147, 164, 168, 180, 181, 190, 191, 193, 195, 196, 198, 199, 9999	0	190	RUN terminal function selection	0, 1, 3, 4, 7, 8, 11 to 16, 18 to 20, 24 to 28, 30 to 36, 38 to 41, 44 to 48, 56, 57, 60 to 66, 68, 70, 80 to 82, 84, 90 to 93, 95, 96, 98 to 101, 103, 104, 107, 108, 111 to 116, 120, 124 to 128, 130 to 136, 138 to 141, 144 to 148, 156, 157, 160 to 166, 168, 170, 180 to 182, 184, 190 to 193, 195, 196, 198, 199, 206, 211 to 213, 242, 306, 311 to 313, 342, 9999	0	⊙	
191	FU terminal function selection		4	191	FU terminal function selection		4	⊙	
192	A,B,C terminal function selection	0, 1, 3, 4, 7, 8, 11 to 16, 20, 25, 26, 46, 47, 64, 68, 80, 81, 90, 91, 95, 96, 98, 99, 100, 101, 103, 104, 107, 108, 111 to 116, 120, 125, 126, 146, 147, 164, 168, 180, 181, 190, 191, 195, 196, 198, 199, 9999	99	192	ABC terminal function selection	0, 1, 3, 4, 7, 8, 11 to 16, 18 to 20, 24 to 28, 30 to 36, 38 to 41, 44 to 48, 56, 57, 60 to 66, 68, 70, 80 to 82, 84, 90, 91, 95, 96, 98 to 101, 103, 104, 107, 108, 111 to 116, 120, 124 to 128, 130 to 136, 138 to 141, 144 to 148, 156, 157, 160 to 166, 168, 170, 180 to 182, 184, 190, 191, 195, 196, 198, 199, 206, 211 to 213, 242, 306, 311 to 313, 342, 9999	99	⊙	
232	Multi-speed setting (speed 8)	0 to 400 Hz, 9999	9999	232	Multi-speed setting (speed 8)	0 to 590 Hz, 9999	9999	⊙	
233	Multi-speed setting (speed 9)	0 to 400 Hz, 9999	9999	233	Multi-speed setting (speed 9)	0 to 590 Hz, 9999	9999	⊙	
234	Multi-speed setting (speed 10)	0 to 400 Hz, 9999	9999	234	Multi-speed setting (speed 10)	0 to 590 Hz, 9999	9999	⊙	
235	Multi-speed setting (speed 11)	0 to 400 Hz, 9999	9999	235	Multi-speed setting (speed 11)	0 to 590 Hz, 9999	9999	⊙	
236	Multi-speed setting (speed 12)	0 to 400 Hz, 9999	9999	236	Multi-speed setting (speed 12)	0 to 590 Hz, 9999	9999	⊙	
237	Multi-speed setting (speed 13)	0 to 400 Hz, 9999	9999	237	Multi-speed setting (speed 13)	0 to 590 Hz, 9999	9999	⊙	
238	Multi-speed setting (speed 14)	0 to 400 Hz, 9999	9999	238	Multi-speed setting (speed 14)	0 to 590 Hz, 9999	9999	⊙	
239	Multi-speed setting (speed 15)	0 to 400 Hz, 9999	9999	239	Multi-speed setting (speed 15)	0 to 590 Hz, 9999	9999	⊙	
240	Soft-PWM operation selection	0, 1	1	240	Soft-PWM operation selection	0, 1	1	⊙	Change the Pr.260 setting as required.
241	Analog input display unit switchover	0, 1	0	241	Analog input display unit switchover	0, 1	0	⊙	
244	Cooling fan operation selection	0, 1	1	244	Cooling fan operation selection	0, 1	1	⊙	
245	Rated slip	0% to 50%, 9999	9999	245	Rated slip	0% to 50%, 9999	9999	⊙	Enabled under V/F control.
246	Slip compensation time constant	0.01 to 10 s	0.5 s	246	Slip compensation time constant	0.01 to 10 s	0.5 s	⊙	The slip compensation function is always enabled under Advanced magnetic flux vector control.
247	Constant-power range slip compensation selection	0, 9999	9999	247	Constant output range slip compensation selection	0, 9999	9999	⊙	
249	Earth (ground) fault detection at start	0, 1	0	249	Earth (ground) fault detection at start	0, 1	0	⊙	The initial value of the FR-E800-[-]1 is that of the parameter initial value group 1.
250	Stop selection	0 to 100 s, 1000 to 1100 s, 8888, 9999	9999	250	Stop selection	0 to 100 s, 1000 to 1100 s, 8888, 9999	9999	⊙	
251	Output phase loss protection selection	0, 1	1	251	Output phase loss protection selection	0, 1	1	⊙	
255	Life alarm status display	0 to 15	0	255	Life alarm status display	0 to 879	0	⊙	
256	Inrush current limit circuit life display	0% to 100%	100	256	Inrush current limit circuit life display	0% to 100%	100	⊙	
257	Control circuit capacitor life display	0% to 100%	100	257	Control circuit capacitor life display	0% to 100%	100	⊙	

FR-E700(SC) parameter list				FR-E800-[-]1 compatible parameter				Parameter setting	
Pr.	Name	Setting range	Initial value	Pr.	Name	Setting range	Initial value	Setting	Remarks
258	Main circuit capacitor life display	0% to 100%	100	258	Main circuit capacitor life display	0% to 100%	100	⊙	
259	Main circuit capacitor life measuring	0, 1	0	259	Main circuit capacitor life measuring	0, 1	0	⊙	
—				260	PWM frequency automatic switchover	0, 10	10	×	In initial setting, PWM carrier frequency automatic reduction function is enabled.
261	Power failure stop selection	0, 1, 2	0	261	Power failure stop selection	0, 1, 2	0	⊙	
267	Terminal 4 input selection	0, 1, 2	0	267	Terminal 4 input selection	0, 1, 2	0	⊙	
268	Monitor decimal digits selection	0, 1, 9999	9999	268	Monitor decimal digits selection	0, 1, 9999	9999	⊙	
270	Stop-on contact control selection	0, 1	0	270	Stop-on-contact control selection	0, 1, 11	0	⊙	
275	Stop-on contact excitation current low-speed multiplying factor	0% to 300%, 9999	9999	275	Stop-on contact excitation current low-speed scaling factor	0% to 300%, 9999	9999	⊙	
276	PWM carrier frequency at stop-on contact	0 to 9, 9999	9999	276	PWM carrier frequency at stop-on contact	0 to 9, 9999	9999	⊙	
277	Stall prevention operation current switchover	0, 1	0	277	Stall prevention operation current switchover	0, 1	0	⊙	
278	Brake opening frequency	0 to 30 Hz	3 Hz	278	Brake opening frequency	0 to 30 Hz	3 Hz	⊙	Set Pr.639 and Pr.640 as required.
279	Brake opening current	0% to 200%	130%	279	Brake opening current	0% to 400%	130%	⊙	
280	Brake opening current detection time	0 to 2 s	0.3 s	280	Brake opening current detection time	0 to 2 s	0.3 s	⊙	
281	Brake operation time at start	0 to 5 s	0.3 s	281	Brake operation time at start	0 to 5 s	0.3 s	⊙	
282	Brake operation frequency	0 to 30 Hz	6 Hz	282	Brake operation frequency	0 to 30 Hz	6 Hz	⊙	
283	Brake operation time at stop	0 to 5 s	0.3 s	283	Brake operation time at stop	0 to 5 s	0.3 s	⊙	
286	Droop gain	0% to 100%	0%	286	Droop gain	0% to 100%	0%	△	The upper limit is changed from 120 Hz to 400 Hz.
287	Droop filter time constant	0 to 1 s	0.3 s	287	Droop filter time constant	0 to 1 s	0.3 s	⊙	
292	Automatic acceleration/deceleration	0, 1, 7, 8, 11	0	292	Automatic acceleration/deceleration	0, 1, 7, 8, 11	0	⊙	
293	Acceleration/deceleration separate selection	0 to 2	0	293	Acceleration/deceleration separate selection	0 to 2	0	⊙	
295	Magnitude of frequency change setting	0, 0.01, 0.10, 1.00, 10.00	0	295	Frequency change increment amount setting	0, 0.01, 0.1, 1, 10	0	⊙	Available in FR-E800-[-]1.
296	Password lock level	0 to 6, 99, 100 to 106, 199, 9999	9999	296	Password lock level	0 to 6, 99, 100 to 106, 199, 9999	9999	⊙	
297	Password lock/unlock	(0 to 5), 1000 to 9998, 9999	9999	297	Password lock/unlock	(0 to 5), 1000 to 9998, 9999	9999	⊙	
298	Frequency search gain	0 to 32767, 9999	9999	298	Frequency search gain	0 to 32767, 9999	9999	⊙	
299	Rotation direction detection selection at restarting	0, 1, 9999	0	299	Rotation direction detection selection at restarting	0, 1, 9999	0	⊙	
338	Communication operation command source	0, 1	0	338	Communication operation command source	0, 1	0	⊙	
339	Communication speed command source	0, 1, 2	0	339	Communication speed command source	0, 1, 2	0	⊙	
340	Communication startup mode selection	0, 1, 10	0	340	Communication startup mode selection	0, 1, 10	0	⊙	
342	Communication EEPROM write selection	0, 1	0	342	Communication EEPROM write selection	0, 1	0	⊙	
343	Communication error count	—	0	343	Communication error count	—	0	⊙	Available in FR-E800-[-]1.
450	Second applied motor	0, 1, 9999	9999	450	Second applied motor	0, 3, 5, 6, 10, 13, 15, 16, 20, 23, 30, 33, 40, 43, 50, 53, 70, 73, 540, 1140, 1800, 1803, 8090, 8093, 9090, 9093, 9999	9999	△	0 → 0. 1 → 10 or 13. Set "70 or 73" for the SF-PR motor. Set Pr.451 = "40" to select V/F control.

FR-E700(SC) parameter list				FR-E800-[-]1 compatible parameter				Parameter setting	
Pr.	Name	Setting range	Initial value	Pr.	Name	Setting range	Initial value	Setting	Remarks
—				451	Second motor control method selection	10 to 12, 20, 40, 9999	9999	×	In the initial setting, the control method and control mode selected in Pr.800 is enabled.
495	Remote output selection	0, 1, 10, 11	0	495	Remote output selection	0, 1, 10, 11	0	⊙	
496	Remote output data 1	0 to 4095	0	496	Remote output data 1	0 to 4095	0	⊙	
497	Remote output data 2	0 to 4095	0	497	Remote output data 2	0 to 4095	0	⊙	
502	Stop mode selection at communication error	0, 1, 2, 3	0	502	Stop mode selection at communication error	0, 1, 2, 6	0	×	Setting value "3" is deleted. Setting value "6" is added. To set the operation at PU disconnection, change the setting value from "3" (in the FR-E700) to "0" (in the FR-E800-[-]1). When "3" is set in the FR-E700 using Ethernet communication or a communication option, consider a setting value "0 or 6" in the FR-E800-[-]1.
503	Maintenance timer	0 (1 to 9998)	0	503	Maintenance timer	0 (1 to 9998)	0	⊙	
504	Maintenance timer alarm output set time	0 to 9998, (9999)	9999	504	Maintenance timer warning output set time	0 to 9998, (9999)	9999	⊙	
—				505	Speed setting reference	1 to 590 Hz	60 Hz	△	The initial value of the FR-E800-[-]1 is that of the parameter initial value group 1.
547	USB communication station number	0 to 31	0	547	USB communication station number	0 to 31	0	⊙	
548	USB communication check time interval	0 to 999.8 s, 9999	9999	548	USB communication check time interval	0 to 999.8 s, 9999	9999	⊙	
549	Protocol selection	0, 1	0	549	Protocol selection	0, 1	0	⊙	Available in FR-E800-[-]1.
550	NET mode operation command source selection	0, 2, 9999	9999	550	NET mode operation command source selection	0, 2, 9999	9999	⊙	
551	PU mode operation command source selection	2 to 4, 9999	9999	551	PU mode operation command source selection	2 to 4, 9999	9999	⊙	
555	Current average time	0.1 to 1.0 s	1 s	555	Current average time	0.1 to 1.0 s	1 s	⊙	
556	Data output mask time	0.0 to 20.0 s	0 s	556	Data output mask time	0.0 to 20.0 s	0 s	⊙	
557	Current average value monitor signal output reference current	0 to 500 A	Inverter rated current	557	Current average value monitor signal output reference current	0 to 500 A	Inverter rated current	⊙	
563	Energization time carrying-over times	(0 to 65535)	0	563	Energization time carrying-over times	(0 to 65535)	0	⊙	
564	Operating time carrying-over times	(0 to 65535)	0	564	Operating time carrying-over times	(0 to 65535)	0	⊙	
—				570	Multiple rating setting [3-phase]	1, 2	2	△	Set "2" to select ND rating. ND rating only for the single-phase 200 V class.
571	Holding time at a start	0.0 to 10.0 s, 9999	9999	571	Holding time at a start	0.0 to 10.0 s, 9999	9999	⊙	
—				609	PID set point/deviation input selection	2 to 5	2	△	
—				610	PID measured value input selection	2 to 5	3	△	
611	Acceleration time at a restart	0 to 3600 s, 9999	9999	611	Acceleration time at a restart	0 to 3600 s, 9999	9999	⊙	
—				639	Brake opening current selection	0, 1	0	△	
—				640	Brake operation frequency selection	0, 1	0	△	
653	Speed smoothing control	0% to 200%	0	653	Speed smoothing control	0% to 200%	0	△	This parameter can be used to adjust the frequency set in Pr.654.
—				654	Speed smoothing cutoff frequency	0 to 120 Hz	20 Hz	△	
665	Regeneration avoidance frequency gain	0% to 200%	100	665	Regeneration avoidance frequency gain	0% to 200%	100	⊙	

FR-E700(SC) parameter list				FR-E800-[-]1 compatible parameter				Parameter setting	
Pr.	Name	Setting range	Initial value	Pr.	Name	Setting range	Initial value	Setting	Remarks
800	Control method selection	20, 30	20	800	Control method selection	0 to 5, 9, 10 to 14, 19, 20, 40	40	△	When "20 or 30" is set in the FR-E700, set "20" in the FR-E800-[-]1 to select Advanced magnetic flux vector control. Use Pr.89 to make adjustments to keep the motor speed constant during variable load operation. To select V/F control, set "40". In the initial setting, V/F control is selected in the FR-E800-[-]1, while Advanced magnetic flux vector control is selected in the FR-E700.
859	Torque current	0 to 500 A, 9999	9999	859	Torque current/Rated PM motor current	0 to 500 A, 9999	9999	⊙	
872	Input phase loss protection selection	0, 1	1	872	Input phase loss protection selection [3-phase]	0, 1	1	⊙	Available for the three-phase power input model only.
882	Regeneration avoidance operation selection	0, 1, 2	0	882	Regeneration avoidance operation selection	0, 1, 2	0	⊙	
883	Regeneration avoidance operation level	300 to 800 V	400/780 VDC	883	Regeneration avoidance operation level	300 to 1200 V	400/780 VDC	⊙	
885	Regeneration avoidance compensation frequency limit value	0 to 10 Hz, 9999	6 Hz	885	Regeneration avoidance compensation frequency limit value	0 to 45 Hz, 9999	6 Hz	⊙	
886	Regeneration avoidance voltage gain	0% to 200%	100%	886	Regeneration avoidance voltage gain	0% to 200%	100%	⊙	
888	Free parameter 1	0 to 9999	9999	888	Free parameter 1	0 to 9999	9999	⊙	
889	Free parameter 2	0 to 9999	9999	889	Free parameter 2	0 to 9999	9999	⊙	
C0 (900)	FM terminal calibration	—	—	C0 (900)	FM terminal calibration	—	—	⊙	Calibrate the parameter as required. Available in FR-E800-[-]1.
C2 (902)	Terminal 2 frequency setting bias frequency	0 to 400 Hz	0 Hz	C2 (902)	Terminal 2 frequency setting bias frequency	0 to 590 Hz	0 Hz	⊙	Calibrate the parameter as required.
C3 (902)	Terminal 2 frequency setting bias	0% to 300%	0%	C3 (902)	Terminal 2 frequency setting bias	0% to 300%	0%	⊙	Calibrate the parameter as required.
125 (903)	Terminal 2 frequency setting gain frequency	0 to 400 Hz	60 Hz	125 (903)	Terminal 2 frequency setting gain frequency	0 to 590 Hz	60 Hz	⊙	Calibrate the parameter as required. The initial value of the FR-E800-[-]1 is that of the parameter initial value group 1.
C4 (903)	Terminal 2 frequency setting gain	0% to 300%	100%	C4 (903)	Terminal 2 frequency setting gain	0% to 300%	100%	⊙	Calibrate the parameter as required.
C5 (904)	Terminal 4 frequency setting bias frequency	0 to 400 Hz	0 Hz	C5 (904)	Terminal 4 frequency setting bias frequency	0 to 590 Hz	0 Hz	⊙	Calibrate the parameter as required.
C6 (904)	Terminal 4 frequency setting bias	0% to 300%	20%	C6 (904)	Terminal 4 frequency setting bias	0% to 300%	20%	⊙	Calibrate the parameter as required.
126 (905)	Terminal 4 frequency setting gain frequency	0 to 400 Hz	60 Hz	126 (905)	Terminal 4 frequency setting gain frequency	0 to 590 Hz	60 Hz	⊙	Calibrate the parameter as required. The initial value of the FR-E800-[-]1 is that of the parameter initial value group 1.
C7 (905)	Terminal 4 frequency setting gain	0% to 300%	100%	C7 (905)	Terminal 4 frequency setting gain	0% to 300%	100%	⊙	Calibrate the parameter as required.
C22 (922)	Frequency setting voltage bias frequency (built-in potentiometer)	0 to 400 Hz	0 Hz	—				×	Operation panel for the FR-E500 (FR-PA02) cannot be used.
C23 (922)	Frequency setting voltage bias (built-in potentiometer)	0% to 300%	0%	—					
C24 (923)	Frequency setting voltage gain frequency (built-in potentiometer)	0 to 400 Hz	60 Hz	—					
C25 (923)	Frequency setting voltage gain (built-in potentiometer)	0% to 300%	100%	—					

FR-E700(SC) parameter list				FR-E800-[-]1 compatible parameter				Parameter setting	
Pr.	Name	Setting range	Initial value	Pr.	Name	Setting range	Initial value	Setting	Remarks
990	PU buzzer control	0, 1	1	990	PU buzzer control	0, 1	1	×	Parameter for the LCD operation panel (FR-LU08).
991	PU contrast adjustment	0 to 63	58	991	PU contrast adjustment	0 to 63	58	×	

4. Option

The following table shows which FR-E700(SC) series options are compatible with the FR-E800 series inverters and their corresponding FR-E800 series options.

Name		Option model	
		FR-E700-[(SC)]	FR-E800 FR-E800-[-]1
Stand-alone	Parameter unit	FR-PU07(BB)	Compatible
	Enclosure surface operation panel	FR-PA07	Compatible
	Parameter unit connection cable	FR-CB20[]	Compatible
	USB cable	MR-J3USBCBL3M (cable length: 3 m)	Compatible
	Intercompatibility attachment	FR-E7AT01 to 03	FR-E7AT01/02/03*1, FR-E8AT03, FR-E8AT04
	DIN rail attachment	FR-UDA01 to 03	FR-UDA03, with restrictions For details, refer to the Instruction Manual.
	Panel through attachment	FR-E7CN01 to 06	FR-E8CN01 to 06
	Totally enclosed structure specification attachment for the FR-E700 series	FR-E7CV01 to 04	To be supported
	Brake resistor	MRS[], MYS[]	Compatible
		FR-ABR-(H)[]K	Compatible
	Brake unit	FR-BU2	Compatible
	Discharging resistor	GZG[], GRZG[], FR-BR	Compatible
	Power factor improving AC reactor	FR-HAL-(H)[]K	Compatible
	Power factor improving DC reactor	FR-HEL-(H)[]K	Compatible
	Radio noise filter	FR-BIF-(H)	Compatible
	Line noise filter	FR-BSF01, FR-BLF	Compatible
	Filterpack	FR-BFP2	Compatible
	EMC Directive compliant noise filter	SF, FR-E5NF, FR-S5NFSA	Compatible
	EMC filter installation attachment	FR-A5AT03, FR-AAT02, FR-E5T(-02)	FR-E8AT03, FR-E7AT03, FR-E5T(-02), FR-A5AT03, FR-AAT02
	FR-CV power regeneration common converter	FR-CV-(H)	Compatible If replacing the converter, use FR-XC.
		Dedicated stand-alone reactor	FR-CVL
	FR-HC high power factor converter	FR-HC-(H)	Compatible If replacing the converter, use FR-HC2.
Surge voltage suppression filter	FR-ASF, EMF	Compatible	

Name		Option model	
		FR-E700-[(SC)	FR-E800
			FR-E800-[-1
Plug-in option (only one option available)	CC-Link communication	FR-A7NC E kit FR-A7NC E kit cover SC and FR-A7NC	FR-A8NC E kit
	DeviceNet communication	FR-A7ND E kit FR-A7ND E kit cover SC and FR-A7ND	FR-A8ND E kit
	LONWORKS communication	FR-A7NL E kit FR-A7NL E kit cover SC and FR-A7NL	Not supported. (Consider replacing the inverter with the FR-F800.)
	PROFIBUS-DP communication	FR-A7NP E kit FR-A7NP E kit cover SC and FR-A7NP	FR-A8NP E kit
	16-bit digital input	FR-A7AX E kit FR-A7AX E kit cover SC and FR-A7AX	FR-A8AX E kit
	Digital output, additional analog output	FR-A7AY E kit FR-A7AY E kit cover SC and FR-A7AY	FR-A8AY E kit
	Relay output	FR-A7AR E kit FR-A7AR E kit cover SC and FR-A7AR	FR-A8AR E kit
	24VDC input	FR-E7DS	FR-E8DS
Control terminals	2 port terminal block for RS-485	FR-E7TR	Under planning
Manual controller / speed controller	Manual controller	FR-AX	Compatible If replacing the option, prepare the same model.
	DC tach. follower	FR-AL	Compatible If replacing the option, prepare the same model.
	Three speed selector	FR-AT	Compatible If replacing the option, prepare the same model.
	Remote speed setter	FR-FK	Compatible If replacing the option, prepare the same model.
	Ratio setter	FR-FH	Compatible If replacing the option, prepare the same model.
	Speed detector	FR-FP	Compatible If replacing the option, prepare the same model.
	Master controller	FR-FG	Compatible If replacing the option, prepare the same model.
	Soft starter	FR-FC	Compatible If replacing the option, prepare the same model.
	Deviation detector	FR-FD	Compatible If replacing the option, prepare the same model.
	Preamplifier	FR-FA	Compatible If replacing the option, prepare the same model.
Others	Pilot generator	QVAH-10	Compatible
	Deviation sensor	YVGC-500W-NS	Compatible
	Frequency setting potentiometer	WA2W 1 kΩ	Compatible
	Analog frequency meter	YM206NRI 1 mA	Compatible
	Calibration resistor	RV24YN 10 kΩ	Compatible
	Inverter setup software	FR-SW3-SETUP-WJ	Not compatible. Use SW1DND-FRC2.

Only one plug-in option can be mounted.

*1 The number of screw holes increases for the FR-E7AT03.

5. Comparison with the FR-E700 series

1. Differences with the FR-E700 series

Item/model		FR-E800	FR-E700
Outline dimensions		Compatible. Note that the product width and height are different between the FR-E800 and FR-E700 inverters for some capacity models. <ul style="list-style-type: none"> • Width for three-phase 200 V 3.7K: 170 mm → 140 mm • Width for three-phase 400 V 0.4K to 1.5K: 140 mm → 108 mm • Height for single-phase 200 V 2.2K: 150 mm → 128 mm 	
Installation size		Compatible. Note that the product width and height are different between the FR-E800 and FR-E700 inverters for some capacity models. (Installation interchange attachments are available.) <ul style="list-style-type: none"> • Width for three-phase 200 V 3.7K: 158 mm → 128 mm • Width for three-phase 400 V 0.4K to 1.5K: 128 mm → 96 mm • Height for single-phase 200 V 2.2K: 138 mm → 118 mm 	
Multiple ratings		Two ratings (LD/ND) ND rating only for the single-phase 200/100 V class.	Not available (ND rating only)
Overload capability	ND rating	150% 60 s, 200% 3 s at surrounding air temperature of 50°C	
	LD rating	120% 60 s, 150% 3 s at surrounding air temperature of 50°C	Not available
Built-in brake transistor		200 V class: 0.4K to 22K 400 V class: 0.4K to 22K 575 V class: 0.75K to 7.5K 100 V class: 0.4K, 0.75K	200 V class: 0.4K to 15K 400 V class: 0.4K to 15K 100 V class: 0.4K, 0.75K
Control method	—	Soft-PWM control / High carrier frequency PWM control	
	V/F control	Available	
	Advanced magnetic flux vector control	Available	
	General-purpose magnetic flux vector control	Not available	Available
	Real sensorless vector control	Available	Not available
	Vector control	Available (Plug-in option FR-A8AP E kit is required.)	Not available
	PM sensorless vector control	Available	Not available
Control mode	Speed control	Available	
	Torque control	Available	Not available
	Position control	Available	Not available
Output frequency		0.2 to 590 Hz (under V/F control) 0.2 to 400 Hz (under other than V/F control)	0.2 to 400 Hz
Frequency resolution	Terminal 2	0.015 Hz / 0 to 60 Hz (0 to 10 V / 12 bits) 0.03 Hz / 0 to 60 Hz (0 to 5 V / 11 bits) 0.03 Hz / 0 to 60 Hz (0 to 20 mA / 11 bits)	0.06 Hz / 0 to 60 Hz (0 to 10 V / 10 bits) 0.12 Hz / 0 to 60 Hz (0 to 5 V / 9 bits)
	Terminal 4	0.015 Hz / 0 to 60 Hz (0 to 10 V / 12 bits) 0.03 Hz / 0 to 60 Hz (0 to 5 V / 11 bits) 0.03 Hz / 0 to 60 Hz (0 to 20 mA / 11 bits)	0.06 Hz/60 Hz (0 to 10 V / 10 bits) 0.12 Hz/60 Hz (0 to 5 V / 9 bits) 0.06 Hz/60 Hz (0 to 20 mA / 10 bits)
Input signal	Terminal function	Major additional functions <ul style="list-style-type: none"> • Signals are added since the control methods and control modes are added. (Mode switching (MC) signal, etc.) • Signals are added since the trace function is added. (Trace trigger input (TRG) signal, etc.) • The Sequence start (SQ) signal is added since the PLC function is added. 	—

Item/model		FR-E800	FR-E700
Input signal	Safety stop signal	[FR-E800/FR-E800-E] Safety stop input (S1) Safety stop input (S2) Safety stop input common (PC) [FR-E800-SCE] SX1, SX2, SY1, SY2, SC1, SC2 (for functional safety)	Available for the safety stop function model only. Safety stop input (S1) Safety stop input (S2) Safety stop input common (PC)
Operational function		Major additional functions Traverse, multiple rating, PLC function, pre-excitation, torque limit, trace function, load fault detection, Ethernet communication (CC-Link IE TSN, EtherNet/IP, etc.)	—
Output signal	Terminal function	Major additional functions <ul style="list-style-type: none"> • Signals are added since the control methods and control modes are added. (Home position return completed (ZP) signal, etc.) • Signals are added since the load fault detection function is added. (Upper limit warning detection (LUP) signal, etc.) • Virtual output terminals for communication operation are added. (NET Y1 to Y4.) 	—
	Terminal FM specifications	1440 pulses/s at full scale	
	Terminal AM specifications	-10 to +10 V / 12 bits	AM: 0 to +10 V (only for the overseas specification models)
	Output signal (terminal FM/AM)	Major additional functions <ul style="list-style-type: none"> • Signals are added since the control methods and control modes are added. (Position command, Torque monitor, etc.) • PID measured value 2 	—
	Output signal (communication)	Major additional functions <ul style="list-style-type: none"> • Signals are added since the BACnet communication is supported. (BACnet reception status, etc.) • Communication station number (PU port, CC-Link) 	—
	Safety stop function	[FR-E800/FR-E800-E] <ul style="list-style-type: none"> • Safety monitor output (SO) • Safety stop input/output terminal common (SOC) • The following signals can be assigned to output terminals. SAFE signal (to monitor safety stop status) SAFE2 signal (output when an alarm or failure is detected) [FR-E800-SCE] <ul style="list-style-type: none"> • No terminals (Supported by the safety communication) • The following signals can be assigned to virtual output terminals for communication operation. SAFE signal (to monitor safety stop status) SAFE2 signal (output when an alarm or failure is detected) 	The following signals can be assigned to output terminals. SAFE signal (to monitor safety stop status) SAFE2 signal (output when an alarm or failure is detected) (Safety stop function model only)
Protection function / warning output	Protective function	Major additional functions Upper limit fault detection (E.LUP), Excessive position fault (E.OD), etc.	—
	Warning function	Major additional functions Stroke limit warning (LP), Duplicate IP address (DIP), IP address fault (IP), Incorrect parameter setting (SE), etc.	—
Operation panel	Standard	Operation panel installed as standard (not removable). 7-segment LED in 4-digit display.	

Item/model		FR-E800	FR-E700
Option		Enclosure surface operation panel (FR-PA07) Parameter unit (FR-PU07(BB)) LCD operation panel (FR-LU08)	Enclosure surface operation panel (FR-PA07) Parameter unit (FR-PU07(BB))
Main circuit terminals R, S, T, U, V, W, P, PR, N, P1, earth (ground) (screw terminal)			
Control circuit terminals	Shape of terminal block	Spring clamp type	[Standard control circuit terminal model] Screw type [Safety stop function model] Spring clamp type
	Contact input	FR-E800: 7, FR-E800-E: 2, FR-E800-SCE: 0	Standard control circuit terminal model: 7, Safety stop function model: 6
	Analog input	FR-E800/FR-E800-E: 2, FR-E800-SCE: 0	2
	Relay output	FR-E800/FR-E800-E/FR-E800-SCE: 1	1
	Open collector output	FR-E800: 2, FR-E800-E/FR-E800-SCE: 0	2
	Pulse output	1 (FM type only)	1
	Analog output	1 (AM type only)	Not available
	Safety input/output signals	[FR-E800/FR-E800-E] S1, S2, SIC, SO, SOC [FR-E800-SCE] SX1, SX2, SY1, SY2, SC1, SC2	S1, S2, PC (Safety stop function model only)
Communication	Ethernet	[FR-E800] Not available [FR-E800-E/FR-E800-SCE] Available (2 ports) CC-Link IE TSN, CC-Link IE Field Network Basic, EtherNet/IP, PROFINET, MODBUS/TCP, BACnet/IP, EtherCAT	[FR-E700-NE] Available (1 port) CC-Link IE Field Network Basic, MODBUS/TCP [Other models] Not available
	Safety communication	[FR-E800/FR-E800-E] Not available [FR-E800-SCE] CC-Link IE TSN safety communication function, CIP Safety, PROFIsafe	Not available
	RS485	[FR-E800] 1 port Mitsubishi inverter protocol, MODBUS RTU, BACnet MS/TP [FR-E800-E/FR-E800-SCE] Not available	
	USB	Available (Mini B connector) USB bus power available (The maximum SCCR is 500 mA.)	Available (Mini B connector) USB bus power unavailable
Plug-in option		Installation size is not compatible. FR-A8AX E kit, FR-A8AY E kit, FR-A8AR E kit, FR-A8NC E kit, FR-A8NP E kit, FR-A8ND E kit, FR-A8AP E kit The option is connected to the inverter for earthing (grounding) through the earth plate of the inverter.	FR-A7AX E kit, FR-A7AY E kit, FR-A7AR E kit, FR-A7NC E kit, FR-A7NP E kit, FR-A7ND E kit
Surrounding air temperature		[100/200/400 V class] -20°C to +60°C (Derate the rated current when using the inverter in a temperature above 50°C.) [575 V class] -10°C to +60°C (Derate the rated current when using the inverter in a temperature above 50°C.)	-10°C to +50°C
Storage temperature		-40°C to +70°C	-20°C to +65°C

Installation precautions

- Installation/removal procedure of the front cover is different. (Refer to the Instruction Manual (Connection).)
- Installation size of plug-in options are not compatible.

Wiring precautions

- When the FR-E700 standard control circuit terminal model is replaced, the terminal block type is changed from the screw type to the spring clamp type. Use of crimp terminals is recommended.
When our authorized crimp terminals are used for the FR-E700 inverters, they cannot be used for the FR-E800 series inverters since they are not compatible with the spring clamp terminal block. (Some crimp terminals may not be used for the FR-E800 series inverters due to differences in size.)
- To use the PU connector, note that wiring methods are different. (Refer to the Instruction Manual (Connection).)

2. Comparison with the FR-E700 series in functions

Parameter/Function	Differences with the FR-E700				Remarks
	Added	Changed	Deleted	Related parameter	
Parameters/functions related to the output frequency (such as Base frequency)		○		Pr.3 and other related parameters	The upper limit of the setting range is changed from 400 Hz to 590 Hz for V/F control. For other control, the upper limit is 400 Hz.
MRS input selection		○		Pr.17	NC contact input specification can be selected for terminal X10.
Stall prevention operation level, etc.		○		Pr.22, Pr.150, Pr.165	Multiple ratings are supported. LD: 120%. ND: 150%.
Operation panel main monitor selection, FM terminal function selection, etc.		○		Pr.52, Pr.54 and other related parameters	Some monitor items are added. (Operation speed, etc.)
Frequency / rotation speed unit switchover	○			Pr.53	
Restart coasting time, etc.		○		Pr.57, Pr.165	The setting range is changed.
Remote function selection		○		Pr.59	The inverter can decelerate the motor to the frequency equal to or lower than the set frequency by the remote setting function.
Retry waiting time		○		Pr.68	<ul style="list-style-type: none"> Setting range of the retry waiting time Operation when an error that does not trigger retry operation occurs during retry waiting time
Special regenerative brake duty		○		Pr.70	The setting range of the brake duty is changed.
Applied motor		○		Pr.71	Addition of motors: <ul style="list-style-type: none"> Mitsubishi Electric high-performance energy-saving motor SF-PR series Mitsubishi Electric geared motor GM series Mitsubishi Electric Vector control dedicated motor SF-V5RU series Mitsubishi Electric high-performance energy-saving motor with encoder SF-PR-SC Mitsubishi Electric PM motor EM-A series
Motor capacity, number of motor poles, etc.		○		Pr.80, Pr.81 and other related parameters	11 to 30kW motors are supported. 12-pole motors are supported in addition to 2-pole to 10-pole motors.
Online auto tuning selection	○			Pr.95	
Built-in potentiometer switching			○	Pr.146	
Output current detection operation selection	○			Pr.166, Pr.167	
Input and output terminal function selection		○		Pr.178 to Pr.192	Some input/output signals are added.
Virtual output terminal selection for communication	○			Pr.193 to Pr.196	
Display corrosion level (environmental impact diagnosis function)	○			Pr.198	
PWM frequency automatic switchover	○			Pr.260	
Brake opening current		○		Pr.279	The upper limit of the setting range is changed to 400%.
Speed deviation excess detection frequency	○			Pr.285	

Parameter/Function	Differences with the FR-E700				Remarks
	Added	Changed	Deleted	Related parameter	
Inverter output terminal filter	○			Pr.289	The terminal response level can be adjusted.
Monitor negative output selection	○			Pr.290	
Overspeed detection level	○			Pr.374	
Initial communication delay time and parameters related to heart beat			○	Pr.387 to Pr.389, Pr.391, Pr.392	
PLC function	○			Pr.414, Pr.415, Pr.498, Pr.675, Pr.1150 to Pr.1199	
Extension output terminal filter	○			Pr.418	
Gateway address	○			Pr.442 to Pr.445	
Digital torque command	○			Pr.447, Pr.448	
Second motor control	○			Pr.450, Pr.451, Pr.453 to Pr.462, Pr.463 and other related parameters	
Speed setting reference	○			Pr.505	
Display estimated main circuit capacitor residual life	○			Pr.506	
Display/reset ABC relay contact life	○			Pr.507	
Display power cycle life	○			Pr.509	
PID signal operation selection	○			Pr.553, Pr.554	
Second frequency search gain	○			Pr.560	
Multiple rating setting	○			Pr.570	
PID output interruption function	○			Pr.575 to Pr.577	
Traverse function	○			Pr.592 to Pr.597	
Functions related to PID set point	○			Pr.609, Pr.610	
Inverter output fault detection enable/disable selection	○			Pr.631	
Brake opening current selection	○			Pr.639	
Brake operation frequency selection	○			Pr.640	
Speed smoothing cutoff frequency	○			Pr.654	
SF-PR slip amount adjustment	○			Pr.673, Pr.674	
Input terminal filter	○			Pr.699	The terminal response level can be adjusted.
Device instance	○			Pr.728, Pr.729	
Second motor constant	○			Pr.737 to Pr.746	
PID unit selection	○			Pr.759	
Operation panel monitor item selection	○			Pr.774 to Pr.776	
Operation frequency during communication error	○			Pr.779	
Acceleration/deceleration time in low-speed range	○			Pr.791, Pr.792	

Parameter/Function	Differences with the FR-E700				Remarks
	Added	Changed	Deleted	Related parameter	
Control mode selection	○	○	○	Pr.800, Pr.702 to Pr.712, Pr.717, Pr.720, Pr.721, Pr.724, Pr.725 and other related parameters	<ul style="list-style-type: none"> • Real sensorless vector control: Speed control and torque control are added. • Vector control: Speed control, torque control, and position control are added. • PM sensorless vector control: Speed control and position control are added. • General-purpose magnetic flux vector control is deleted. • The setting value to select V/F control is changed to "40".
Real sensorless vector control, Vector control	○			Pr.801, Pr.803 to Pr.817, Pr.820, Pr.821, Pr.823 to Pr.825, Pr.828, Pr.830, Pr.831, Pr.833 to Pr.835, Pr.840 to Pr.848, Pr.858, Pr.874, Pr.877 to Pr.881 and other related parameters	
Analog input offset adjustment	○			Pr.849	
Low speed detection	○			Pr.865	
Terminal 4 function	○			Pr.858, Pr.932 to Pr.933	
AM output filter	○			Pr.867	
Speed detection hysteresis	○			Pr.870	
OLT level setting	○			Pr.874	
Energy saving monitoring	○			Pr.891 to Pr.899	
PID display	○			Pr.934 to Pr.935	
Display safety fault code	○			Pr.986	
Operation panel setting dial push monitor selection	○			Pr.992	
Fault initiation	○			Pr.997	
PM parameter initialization	○			Pr.998	
Automatic parameter setting	○			Pr.999	
Clock function	○			Pr.1006 to Pr.1008	
Trace function	○			Pr.1020 to Pr.1047	
Monitor filter	○			Pr.1106 to Pr.1108	Monitor filters for the torque monitor, running speed monitor, and excitation current monitor.
Inverter-to-inverter link function	○			Pr.1124, Pr.1125	
Inverter identification enable/disable selection	○			Pr.1399	
Ethernet communication (CC-Link IE TSN, etc.)	○			Pr.1424 to Pr.1457	FR-E700-NE supports CC-Link IE Field Network Basic, MODBUS/TCP, MELSOFT / FA product connection, and SLMP.
Load characteristics fault detection	○			Pr.1480 to Pr.1492	
Functional safety (SIL3)	○			Pr.S001 to Pr.S027, Pr.S051, Pr.S055, Pr.S061, Pr.S066, Pr.S070, Pr.S071	
Encoder feedback control	○			Pr.285, Pr.359, Pr.367 to Pr.369, Pr.376	
Orientation control	○			Pr.350 to Pr.359, Pr.361 to Pr.366, Pr.369, Pr.393, Pr.396 to Pr.399	
6-point frequency jump	○			Pr.552	

Parameter/Function	Differences with the FR-E700				Remarks
	Added	Changed	Deleted	Related parameter	
Increased magnetic excitation deceleration	○			Pr.660 to Pr.662	
Advanced optimum excitation control	○			Pr.60, Pr.9, Pr.71, Pr.80, Pr.81, Pr.83, Pr.84, Pr.800	
CC-Link IE TSN safety communication function	○			Pr.S030 to Pr.S032	
CIP safety	○			Pr.S135 to Pr.S149	
PROFIsafe	○			Pr.S089	
Free thermal (Electronic thermal O/L relay)	○			Pr.600 to Pr.604, Pr.692 to Pr.696	

REVISIONS

Revision date	Version	Revision
Dec. 2020	B	<p>Added Capacity (11K/15K), option (FR-E8CN01 to 06), length of conductive part of the 2-wire ferrule terminal</p> <p>Edited Setting value "8888" added for Pr.11 Setting range changed for Pr.52, Pr.71, Pr.450, Pr.178 to Pr.184, Pr.190 to Pr.192, and Pr.800 Setting value "0" deleted for Pr.37 Note on FR-BFP2 deleted Restrictions for FR-UDA03 EMC filter installation attachment Position control (simple positioning), home position return completed signal, position command, excessive position fault, stroke limit warning, ST language, PTC thermistor, Optimum excitation control under Advanced magnetic flux vector control, Vector control, FR-PU07, increased magnetic excitation deceleration Comparison with the FR-E700 series</p>
Dec. 2022	C	<p>FR-E810W Notes on the JOG2 signal, Pr.0, and Pr.37 added Comparison with the FR-E700 series</p>