

Precautions to Acquire the Type Approval Certificate for Ship Classifications of ABS, BV, DNV, LR, NK, and RINA (For Network Related Products)

■Date of Issue

February 2017 (Ver. B: June 2021)

■Relevant Models

CC-Link IE Field Network and CC-Link IE TSN

Thank you for your continued support of Mitsubishi Electric programmable controllers, MELSEC series.

The following describes the detail of precautions for using CC-Link IE Field Network and CC-Link IE TSN as the system that the classification societies have approved.

For the models, numbers, and expiration dates that each classification society has approved, please consult your local Mitsubishi representative.

1 Classification Societies that Issue the Type Approval Certificates

CC-Link IE Field Network and CC-Link IE TSN have acquired the Type Approval Certificates from the following classification societies.

- American Bureau of Shipping (Abbreviation: ABS)
- Bureau Veritas (Abbreviation: BV)
- DNV AS (Abbreviation: DNV)
- Lloyd's Register of Shipping (Abbreviation: LR)
- Nippon Kaiji Kyokai (Abbreviation: NK)
- Registro Italiano Navale (Abbreviation: RINA)

2 Precautions



This chapter describes the detail of precautions for using CC-Link IE Field Network and CC-Link IE TSN as the approved system.

Before using the products, make sure to read through the user's manual for the product used and QCPU User's Manual (Hardware Design, Maintenance and Inspection) (SH-080483ENG) or MELSEC iQ-R Module Configuration Manual (SH-081262ENG).

Control panel

- The control panel must be conductive.
- When fixing a top or bottom plate of the control panel with bolts, remove the protective coating from both the plate and bolt surfaces to ensure that they come into electric contact.
- When using an inner plate, ensure electric contact with the control panel. For instance, galvanize an inner plate at a thickness of 10 μ m or more. In addition, remove the coating of the fixing bolt area of both the inner plate and control panel to ensure conductivity in the largest possible area.
- Ground the control panel with a thick ground cable (cross-sectional area: 2mm² or more).
- To suppress the leakage of radio waves, the control panel must have the structure where the clearance gaps are reduced as much as possible. Ensure that the space between the control panel and its doors is as small as possible by attaching EMI gaskets between them. Also, the diameter of the cable hole must be 10cm or less.
- To ensure the electric contact between the control panel and its doors, remove the coating of the contact areas, attach EMI gaskets, and connect the panel and the doors with thick wires.

■ Structure example inside the control panel

-  Shows an inner plate (galvanized at a thickness of 10µm or more). The inner plate is fixed to the control panel with screws for conductivity.
-  Shows EMI gaskets*1.

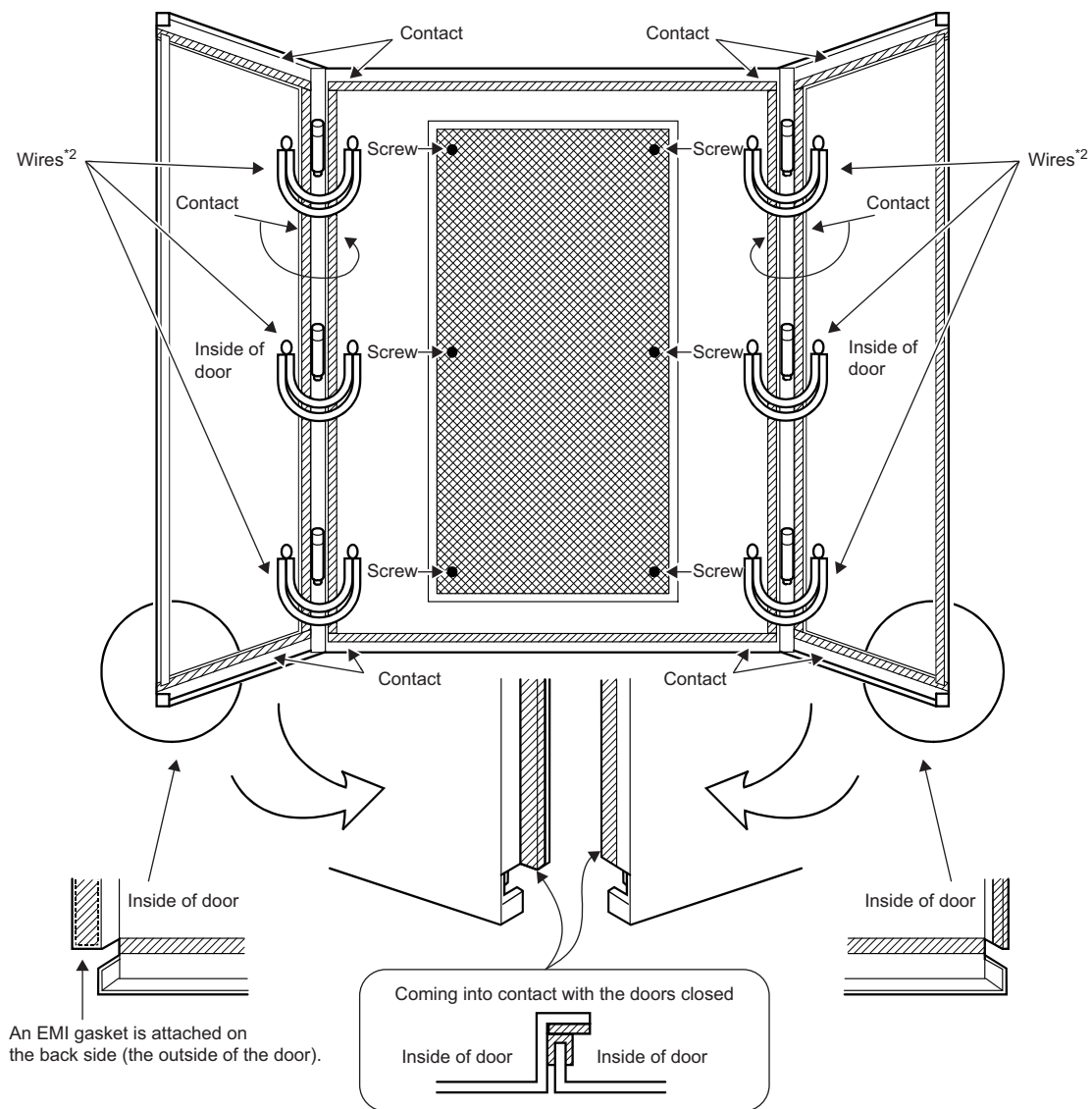

*1 Do not apply coating to the parts where EMI gaskets are to be attached. Use electrically conductive adhesive tape to attach EMI gaskets.
 *2 These wires are used to strengthen conductivity between the doors and control panel.

Cable

Use a shielded cable for a cable coming out of the control panel and attach a cable clamp fitting because the cable releases noise by functioning like an antenna.

FA-A-0233-B

Noise filter

Make sure to attach a noise filter to the power cable.

Use the HF3010C-SZA noise filter (manufactured by SOSHIN ELECTRIC CO., LTD.) or the equivalent.

- Do not bundle the cables on the input side and output side of the noise filter. If bundled, the output side noise will be induced into the input side cables from which the noise was filtered.

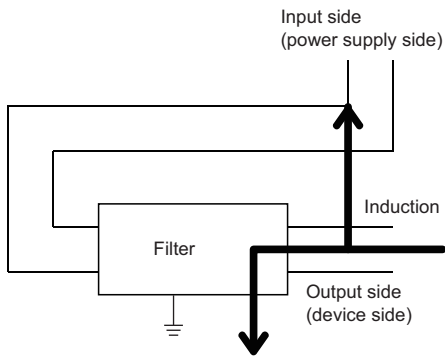

- Defect example
When the cables for input wiring and output wiring are bundled, noise is induced.

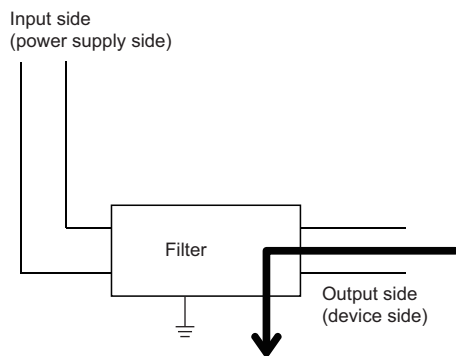

- Improvement example
Carry out cable laying taking the distance between input wiring and output wiring.

- Connect the noise filter's ground terminal to the control panel with the shortest possible cable (approx.10cm).

Ferrite core

Twist a power cable (including a ground cable).

Attach a ferrite core to the twisted power cable.

Using the ZCAT3035-1330 (manufactured by TDK Corporation) for a ferrite core is recommended.

Equipment maintenance

To use CC-Link IE Field Network or CC-Link IE TSN as the approved system, maintenance and inspection must be performed by a maintenance worker.

The maintenance worker here refers to a person who has taken appropriate education and training, has work experience, can recognize hazards in operation and avoid them.

Cable clamp fitting, right side of a base unit

Attach a ship classification compliant cable clamp cover (AD75CK-CV) to a cable clamp fitting, and a ship classification compliant base cover (R35B-CV1) to the right side of a base unit (excluding a RQ extension base unit).

■ Example of a noise filter and a ferrite core set inside the control panel

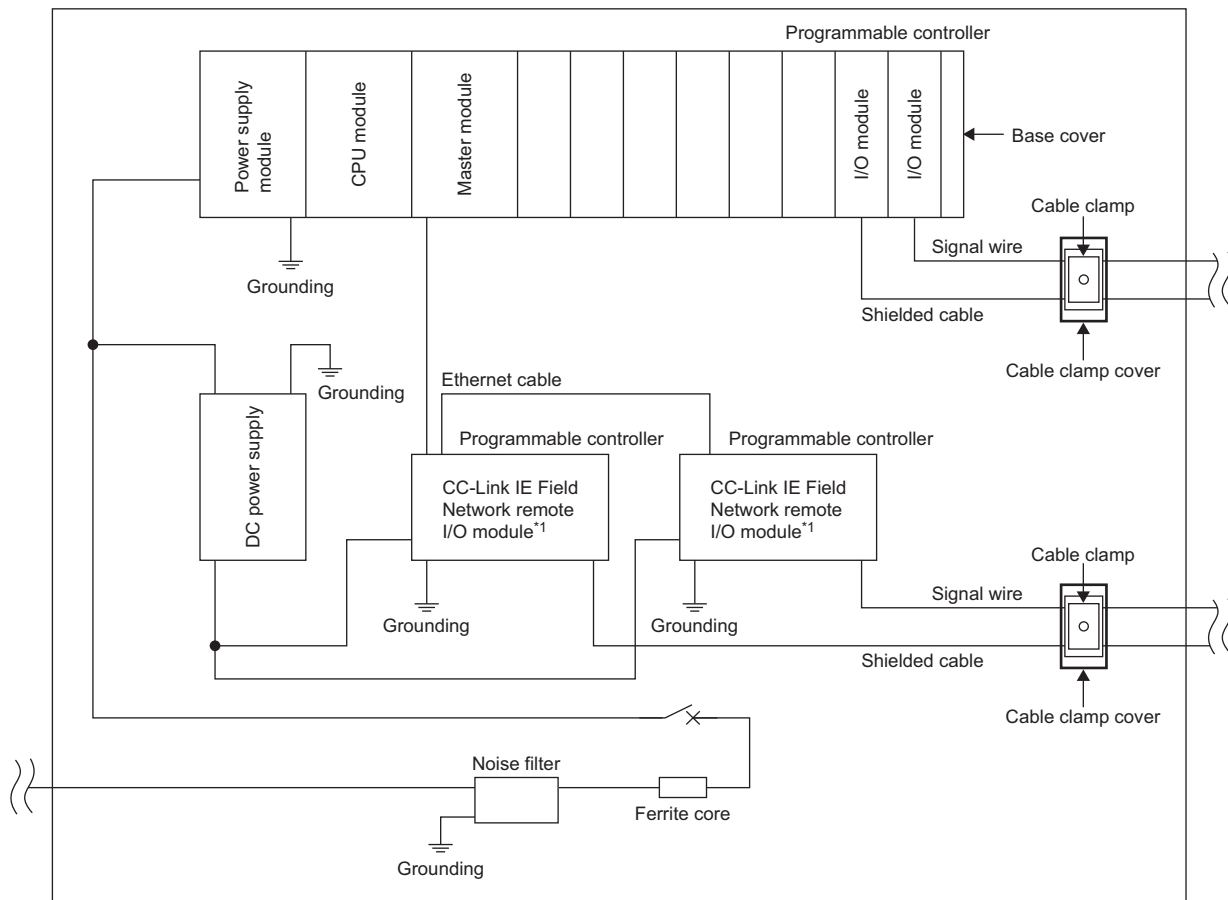

*1 Either CC-Link IE Field Network or CC-Link IE TSN can be used.

FA-A-0233-B

REVISIONS

Version	Date of Issue	Revision
-	February 2017	First edition
A	February 2019	Available for e-Manual Viewer
B	June 2021	Change in the title of this bulletin and description in "1 Classification Societies that Issue the Type Approval Certificates" due to the name change from DNV GL to DNV

TRADEMARKS

The company names, system names and product names mentioned in this technical bulletin are either registered trademarks or trademarks of their respective companies.

In some cases, trademark symbols such as '™' or '®' are not specified in this technical bulletin.