

TECHNICAL BULLETIN

[Issue No.] T99-0053-A

[Page] 1/6

[Title] Lloyd's Certificate Approval and Relevant Requirements

[Date of Issue] June, '05

[Relevant Models] MELSEC-Q Series Models*

redundant CPU module, redundant power supply module, redundant main base unit and redundant extension base unit and tracking cable

*: Please go to MELFANSweb homepage (<http://www.nagoya.melco.co.jp/english>) for a list of relevant models.

Thank you for your continued support of Mitsubishi programmable logic controllers, MELSEC-Q series.

We are pleased to inform that the following MELSEC-Q Series products have additionally acquired the type approval certificate on the Programmable Logic Control Units from Lloyd's (Lloyd's Register of Shipping).

- Redundant CPU module (referred to as "Redundant CPU")
Relevant model: Q12PRHCPU, Q25PRHCPU
- Q64RP redundant power supply module (referred to as "Redundant power supply module")
Relevant model: Q64RP
- Q38RB redundant main base unit (referred to as "Redundant main base unit")
Relevant model: Q38RB
- Q68RB redundant extension base unit (referred to as "Redundant extension base unit")
Relevant model: Q68RB
- QC10TR, QC30TR tracking cable
Relevant model: QC10TR, QC30TR

In the Regulations for the Performance of Type Test, Part 1, Edition 2003, some stringent restrictions have been added, such as emissions (electromagnetic interference) of 24dB or less (@3m) in a frequency range from 156 to 165MHz are only permitted. Therefore, make sure to observe the restrictions in section 2 for use.



1. Lloyd's certification

The following explains the acquired Lloyd's certification.

Acquired certification

Item	Description
Accreditation organization	Lloyd's Register of Shipping
Certificate No.	02/10042
Category	Programmable Logic Controller (ENV1, ENV2)
Test standard	Regulations for the Performance of Type Test, Part 1, Edition 2003
Term of validity	Until November 17, 2007

TECHNICAL BULLETIN

[Issue No.] T99-0053-A

[Page] 2/6

[Title] Lloyd's Certificate Approval and Relevant Requirements

[Date of Issue] June, '05

[Relevant Models] MELSEC-Q Series Models*

redundant CPU module, redundant power supply module, redundant main base unit and redundant extension base unit and tracking cable

Certification details

Item	Description	Remarks
Environment	Temperature: 5 to 55°C	-
	Humidity: 95% or less	-
	Vibration resistance: 0.7G (13.2 to 100Hz)	Refer to 2. Requirements, item (1).
EMC	EMC: Any given place on vessel (including bridge and deck)	Refer to section 2. Requirements, item (2) to (5).

The Lloyd's approved MELSEC-Q Series redundant CPU/redundant power supply module/redundant main base unit/redundant extension base unit/tracking cable must be used under the above environment.

2. Requirements

When using the MELSEC-Q Series redundant CPU/redundant power supply module/redundant main base unit/redundant extension base unit/tracking cable in the system requiring Lloyd's approval, make sure to observe the following requirements.

(1) Base unit installation

For the redundant main base unit and redundant extension base unit, fix them to the control panel at the five points with screws.

(2) Control panel

(a) The control panel must be conductive.

(b) When fixing a top or bottom plate of the control panel with bolts, remove the protective coating from both the plate and bolt surfaces to ensure that they come into electrical contact.

(c) When using an inner plate, ensure electric contact with the control panel, as an example. (Plating thickness: 10µm or more) (See Fig. 1.)

In addition, remove the coating of the fixing bolt area of both the inner plate and control panel to ensure conductivity in the largest area as possible.

(d) Ground the control panel with a thick grounding cable (Cross-sectional area: 2 mm² or more).

(e) In order to suppress the leakage of radio waves, the structure must have minimal openings.

Ensure that the space between the control panel and its door is small as possible by attaching some EMI gaskets between them. Also, the diameter of the cable hole must be 10cm or less.

(f) To ensure the electric contact between the control panel and its door, remove the coating of the contact areas, attach EMI gaskets and conducting adhesive tapes and connect the panel and the doors with thick wires. (See Fig. 1.)

TECHNICAL BULLETIN

[Issue No.] T99-0053-A

[Page] 3/6

[Title] Lloyd's Certificate Approval and Relevant Requirements

[Date of Issue] June, '05

[Relevant Models] MELSEC-Q Series Models*

redundant CPU module, redundant power supply module, redundant main base unit and redundant extension base unit and tracking cable

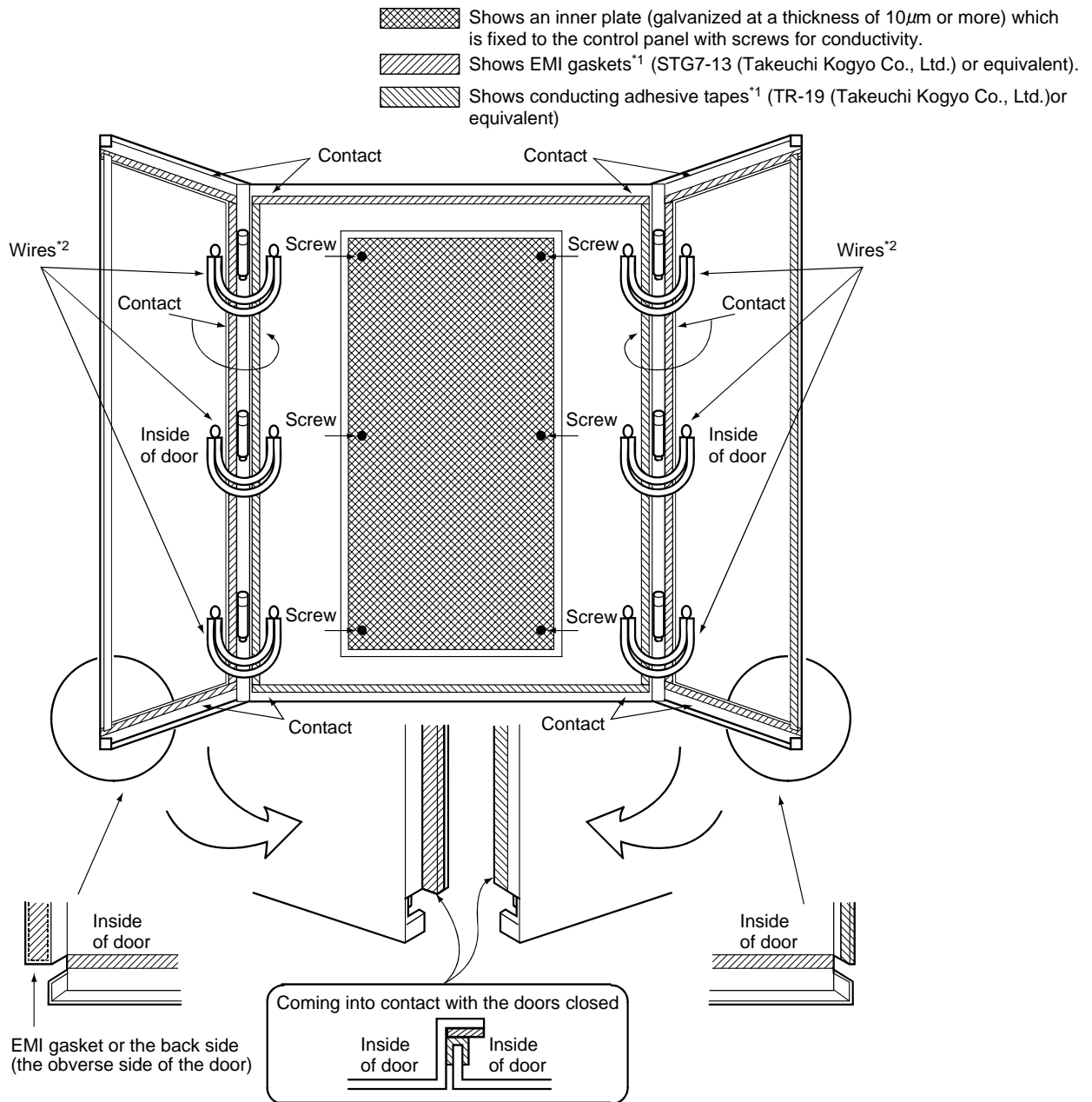

*1 Do not apply coating to the parts where EMI gaskets and conducting adhesive tapes are to be attached.

*2 These wires are used to strengthen conductivity between the doors and control panel.

Fig.1. Example of Control Panel Inside

[Issue No.] T99-0053-A

[Page] 4/6

[Title] Lloyd's Certificate Approval and Relevant Requirements

[Date of Issue] June, '05

[Relevant Models] MELSEC-Q Series Models*

redundant CPU module, redundant power supply module, redundant main base unit and redundant extension base unit and tracking cable

(3) Cable

As a cable coming out from the control panel will release noise by functioning like an antenna, make sure to use a shield cable. (See [1] in Fig. 3.)

(4) Noise filter

Make sure to attach a noise filter to the power cable. (See [2] in Fig.3.)

Use the SF1252 noise filter (ROXBURGH ELECTRONICS LTD) or the equivalent.

(a) Do not install the input and output cables of the noise filter together to prevent the input noise inducting into the output cable.

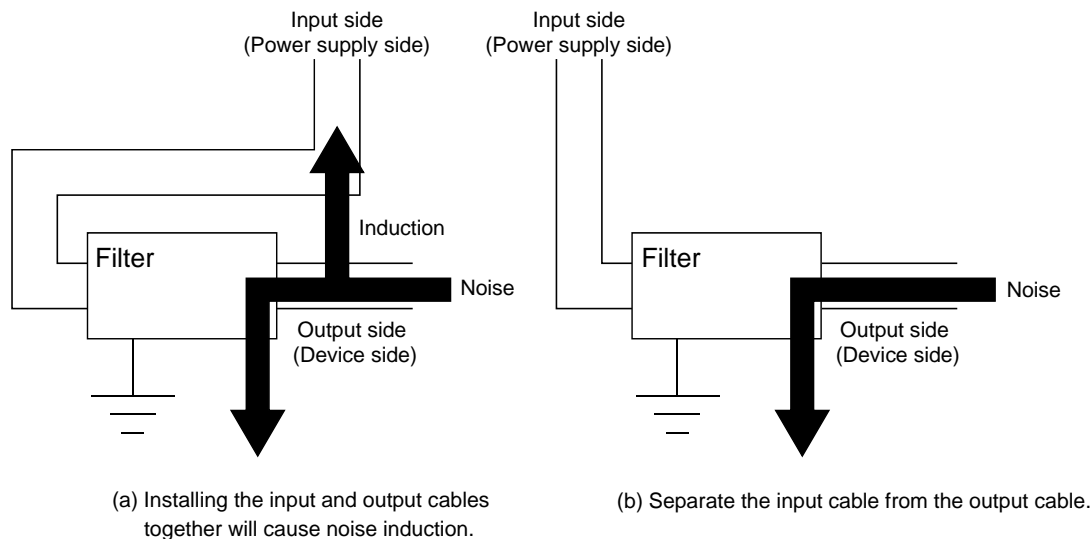

Fig.2. Precautions on noise filter

(b) Connect the noise filter's ground terminal to the control panel with the shortest cable as possible (approx. 10cm (3.94 in.) or less).

(5) Ferrite core

Ferrite cores should be attached to all of the cables (including power cables) coming out from the control panel.

(a) Power cable

Twist the power cables (including grounding wires).

Attach a ferrite core to the twisted power cables at the position closest to the power supply module as possible. (See [3] in Fig.3.)

If attached at an improper position, the ferrite core will not function effectively.

It is recommended to use Tokin's ESD-SR-25.

(b) Signal cable

Attach a ferrite core to the signal cable (shield cable) inside the control panel at the position closest to the cable hole. (See [4] in Fig.3.)

If attached at an improper position, the ferrite core will not function effectively.

It is recommended to use Tokin's ESD-SR-25.

TECHNICAL BULLETIN

[Issue No.] T99-0053-A

[Page] 5/6

[Title] Lloyd's Certificate Approval and Relevant Requirements

[Date of Issue] June, '05

[Relevant Models] MELSEC-Q Series Models*

redundant CPU module, redundant power supply module, redundant main base unit and redundant extension base unit and tracking cable

(6) Device maintenance and inspection

When using the MELSEC-Q Series redundant CPU/redundant power supply module/redundant main base unit/redundant extension base unit/tracking cable as the Lloyd's approved product, the redundant CPU must be maintained and inspected by the maintainer, i.e., the personnel who has been well-experienced, educated, trained and be able to recognize and avoid the danger accompanying operations.

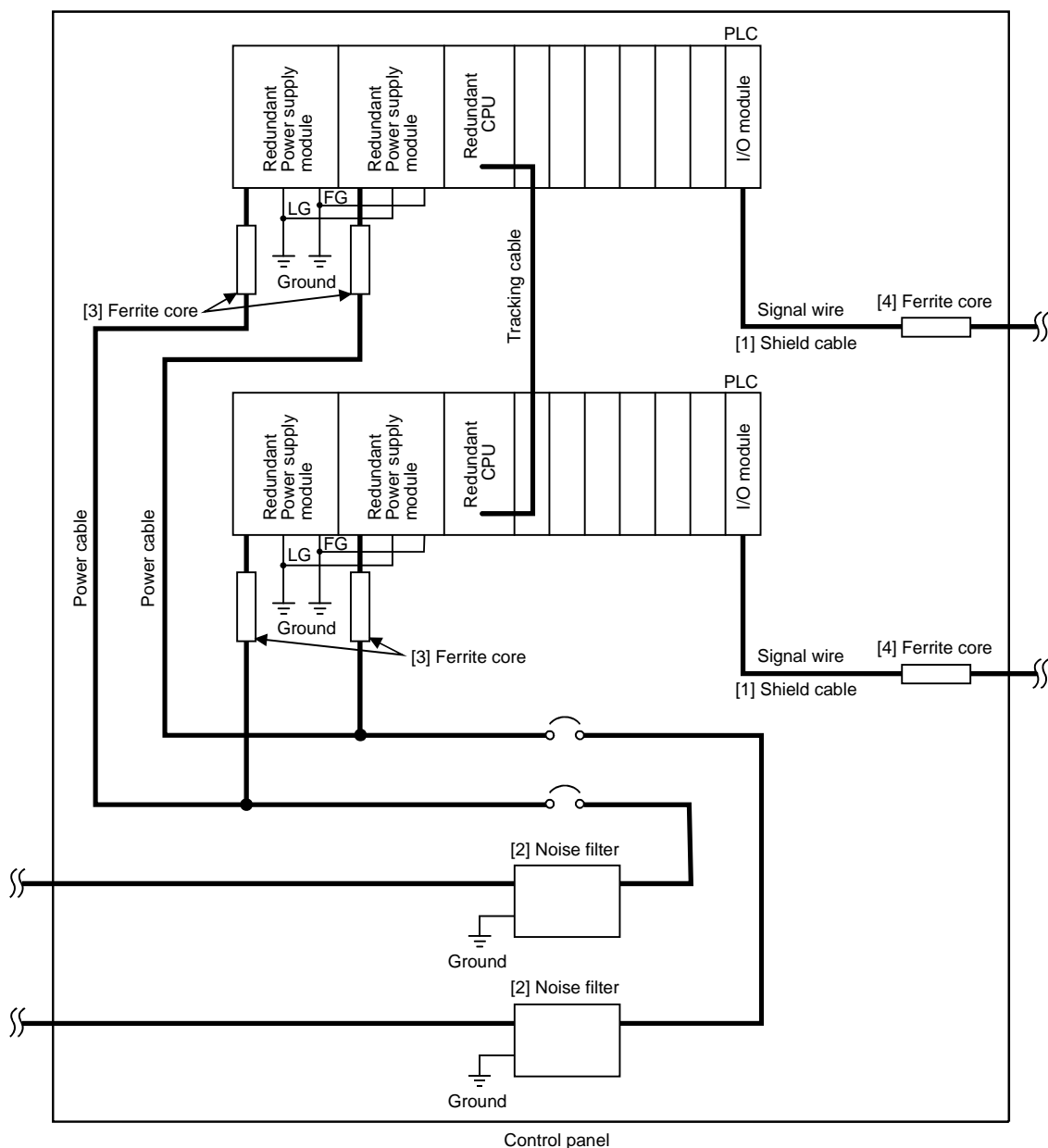

Fig. 3. Example of Noise Filter, Line Filter and Ferrite Cores Set inside Control Panel

MITSUBISHI ELECTRIC CORPORATION

HEAD OFFICE : 1-8-12, OFFICE TOWER Z 14F HARUMI CHUO-KU 104-6212, JAPAN
NAGOYA WORKS : 1-14, YADA-MINAMI 5-CHOME, HIGASHI-KU, NAGOYA, JAPAN

TECHNICAL BULLETIN

[Issue No.] T99-0053-A

[Page] 6/6

[Title] Lloyd's Certificate Approval and Relevant Requirements

[Date of Issue] June, '05

[Relevant Models] MELSEC-Q Series Models*

redundant CPU module, redundant power supply module, redundant main base unit and redundant extension base unit and tracking cable

Sub No.	Revision
A	<ul style="list-style-type: none">• The certification details on Lloyd's certification have been partly changed (from vibration to vibration resistance).• "Tracking cable" has been added to "Relevant Models".