

[Issue No.] HIME-T-P-0007F

[Title] ABS Certificate Approval and Relevant Requirements FX3U Series PLC

[Date of Issue] Mar. 2007 (Ver. F: Jan. 2017)

[Relevant Models] MELSEC-F series

The following MELSEC-F FX3U Series products have also acquired the type approval certificate on the Programmable Logic Controller from ABS (American Bureau of Shipping).

- FX3U Series main unit
- FX3U Series special adapter
- FX3U Series expansion board
- FX3U Series memory cassette
- FX3U Series display module

### 1. Applicable Models

Type	Model Name
Main Units	FX3U-16MR/ES, FX3U-16MT/ES, FX3U-16MT/ESS, FX3U-32MR/ES, FX3U-32MT/ES, FX3U-32MT/ESS, FX3U-48MR/ES, FX3U-48MT/ES, FX3U-48MT/ESS, FX3U-64MR/ES, FX3U-64MT/ES, FX3U-64MT/ESS, FX3U-80MR/ES, FX3U-80MT/ES, FX3U-80MT/ESS, FX3U-128MR/ES, FX3U-128MT/ES, FX3U-128MT/ESS, FX3U-16MR/DS, FX3U-16MT/DS, FX3U-16MT/DSS, FX3U-32MR/DS, FX3U-32MT/DS, FX3U-32MT/DSS, FX3U-48MR/DS, FX3U-48MT/DS, FX3U-48MT/DSS, FX3U-64MR/DS, FX3U-64MT/DS, FX3U-64MT/DSS, FX3U-80MR/DS, FX3U-80MT/DS, FX3U-80MT/DSS
Special Adapters	FX3U-232ADP, FX3U-485ADP, FX3U-4AD-ADP, FX3U-4DA-ADP, FX3U-4AD-PT-ADP, FX3U-4AD-TC-ADP, FX3U-4HSX-ADP, FX3U-2HSY-ADP, FX3U-232ADP-MB, FX3U-485ADP-MB
Expansion Boards	FX3U-USB-BD, FX3U-232-BD, FX3U-485-BD, FX3U-422-BD, FX3U-CNV-BD
Memory Cassettes	FX3U-FLROM-16, FX3U-FLROM-64, FX3U-FLROM-64L
Display Module	FX3U-7DM

### 2. ABS certification

The following table explains the acquired ABS certification.

#### Acquired certification

Item	Description
Accreditation organization	American Bureau of Shipping
Certificate No.*	-
Category	Programmable Logic Controller
Test standard*	-
Term of validity*	-

\* Please ask your local Mitsubishi Electric distributor for the certificate No., test standard and term of validity.

**Certification details**

The ABS approved MELSEC-F FX3U Series main unit, Special adapter, Expansion board, Memory cassette and Display module must be used under the following environment.

Item	Description	Remarks
EMC	EMC: Any given place on vessel (Bridge and Deck Zone is included)	Refer to section 3.
Others	The tests in the presence of the Surveyor from ABS are required where it is used for control, monitoring and safety system of propulsion machinery, propulsion boilers vital auxiliary pumps and electrical generating plants, etc. The performance tests are to be carried out at the assembled plant before installation onboard or after installation.	-

**3. Requirements**

When using the MELSEC-F FX3U Series main unit, Special adapters, Expansion board, Memory cassette and Display module in a system requiring ABS approval, make sure the following requirements are observed:

**In the following requirements, the "1) e) control cabinet" and "3) noise filter" are additional, when located on the Bridge or Deck Zone.**

**1) Control cabinet**

- a) The control cabinet must be conductive.
- b) Ground the control cabinet with the thickest possible grounding cable.
- c) To ensure that there is electric contact between the control cabinet and its door, connect the cabinet and its doors with thick wires. (See Fig. 1 and Fig. 2.)
- d) In order to suppress the leakage of radio waves, the control cabinet structure must have minimal openings. Also, wrap the cable holes with a shielding cover or other shielding devices. (See Fig. 1 and Fig. 2.)
- e) The gap between the control cabinet and its door must be small as possible by attaching some EMI gaskets between them. **[Additional requirements when located on the Bridge or Deck Zone]**  
Remove coating of the contact area of the control cabinet and its door, and attach the EMI gasket with conductive adhesive tape. (See Fig. 2.)  
Mitsubishi's EMC tests have been carried out on a cabinet with an attached EMI gasket. The damping characteristics of the EMI gasket were 69 dB mean (150 kHz to 100 MHz).

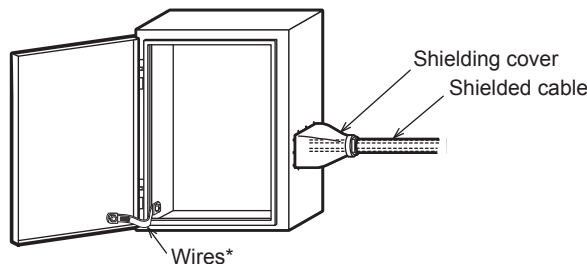

\* These wires are used to improve the conductivity between the door and control cabinet.

**Fig.1. Control Cabinet Example 1 (Not located on the Bridge or Deck Zone)**

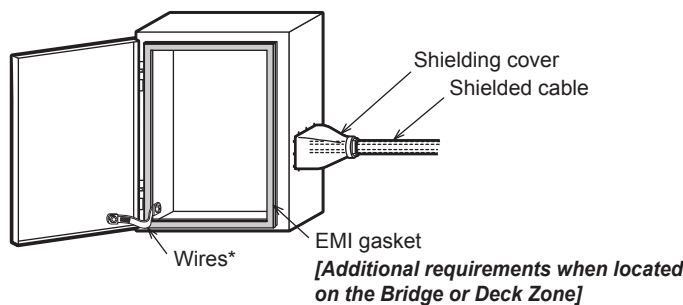

\* These wires are used to improve the conductivity between the door and control cabinet.

**Fig.2. Control Cabinet Example 2 (Located on the Bridge or Deck Zone)**

Mitsubishi's EMC tests have been carried out on a cabinet with the damping characteristics of 46.8 dB max. and 26.4 dB mean (measured by 3 m method with 30 MHz to 2 GHz).

**2) Cables**

- a) Use shielded cables for the cables that protrude out of the control cabinet.
- b) Connect the shields, such as the shielded cable and the shielding cover, to the grounded control cabinet.

**3) Noise filter [Additional requirements when located on the Bridge or Deck Zone]**

Make sure to attach a noise filter to the power cable. (See Fig. 4.)

Mitsubishi's EMC tests have been carried out on a noise filter with the common mode damping characteristics (Fig. 3) of the 50 dB mean at 100 kHz to 300 kHz and 90 dB mean at 6 MHz to 20 MHz.

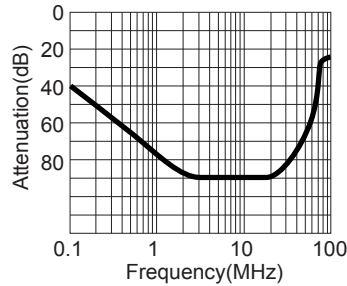

**Fig.3. Damping characteristics of noise filter**

- a) Separate and lay the input (power source side) and output (device side) cable of the noise filter. Do not bundle the input cable together and do not lay it close to the output cable. If input and output cables are installed together interface may be caused due to noise being inducted to the input cable from the output cable.

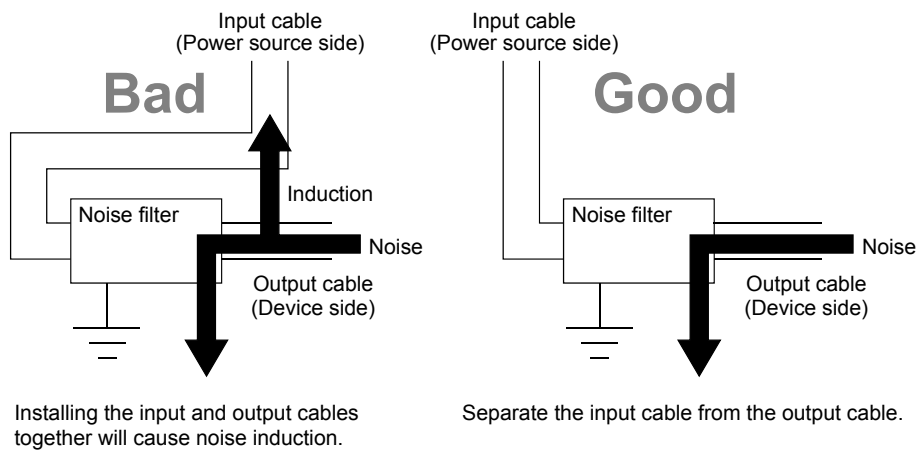

**Fig.4. Precautions on noise filter**

- b) Grounding wires of the noise filter should be as short as possible.

**Revised History**

<b>Date</b>	<b>Revision</b>	<b>Description</b>
Mar. 2007	A	First Edition
Jul. 2007	B	The requirements when located on the Bridge or Deck Zone are added.
Feb. 2008	C	FX3U-232ADP and FX3U-485ADP are added.
Jan. 2010	D	Update of Test standard
Nov. 2015	E	Partial design change
Jan. 2017	F	Acquired certification is modified

The company and product names described in this technical bulletin are trademarks or registered trademarks of their respective companies.