

FACTORY AUTOMATION

# MELSERVO-J5 Series CC-Link IE TSN Drive Safety Device Introduction Guide AC Servo System

**e-Factory**





# INTRODUCTION

This manual explains an example of the wiring for receiving safety signal data with the AC servo MELSERVO-J5, and the setting procedure using the engineering tools (GX Works3, MR Configurator2).

Please carefully read this manual and related materials before using the products, fully understand the functions and performance of the programmable controller and servo amplifier, and use them correctly. For descriptions of the terms used in this manual, check “Terminology” listed in each manual.

When using the sample program introduced in this manual with an actual system, fully verify that there are no problems with control in that system.

## PRODUCT APPLICATIONS

Regarding the product applications, please check the contents of the product warranty below.

- MELSEC iQ-R Programmable Controller CPU Module User's Manual, manual No.: SH-082488ENG “CONDITIONS OF USE FOR THE PRODUCT”
- MR-J5 User's Manual (Hardware), manual No.: SH-030298ENG “Warranty”
- MELSEC iQ-R Motion Module User's Manual (Application), manual No.: IB-0300411ENG “Warranty”

## RELEVANT MANUALS

[○: Available, —: Not available]

Manual name <manual number>	Available form	
	e-Manual	PDF
MELSEC iQ-R Programmable Controller CPU Module User's Manual [SH-082488ENG]	○	○
MELSEC iQ-R Motion Module User's Manual (Application) [IB-0300411ENG]	○	○
MELSEC iQ-R Motion Module User's Manual (Network) [IB-0300426ENG]	○	○
MELSEC iQ-R Programming Manual (Module Dedicated Instructions) [SH-081976ENG]	○	○
MELSEC iQ-R CC-Link IE TSN User's Manual (Application) [SH-082129ENG]	○	○
MR-J5 User's Manual (Hardware) [SH-030298ENG]	○	○
MR-J5 User's Manual (Function) [SH-030300ENG]	○	○
MR-J5 User's Manual (Troubleshooting) [SH-030312ENG]	○	○
MR-J5-G/MR-J5W-G User's Manual (Parameters) [SH-030308ENG]	○	○
CC-Link IE TSN Remote I/O Module (With Safety Functions) User's Manual [SH-082227ENG]	○	○
GX Works3 Operating Manual [SH-081215ENG]	○	○
MELSEC iQ-R Safety Application Guide [SH-081538ENG]	○	○

# CONTENTS

---

INTRODUCTION	1
PRODUCT APPLICATIONS	1
RELEVANT MANUALS	1
Servo Amplifier Characteristics	4
Safety Communication Characteristics	7
System Configuration	8
About the Tools Used	9
Setting Flow	11
<b>CHAPTER 1 Preparation</b>	<b>12</b>
1.1 Devices to Prepare	12
1.2 Registering a Profile	14
1.3 Wiring	15
<b>CHAPTER 2 Creating a Project</b>	<b>19</b>
2.1 Creating a New Project	19
2.2 Programmable Controller Initialization	21
2.3 Registering User Information	23
2.4 Module Configuration	24
2.5 Parameter Settings	28
Network configuration settings	28
Servo Amplifier	32
Parameter settings (safety remote I/O module)	35
2.6 Safety Communication Settings	39
Safety function setting	39
Safety communication settings	40
2.7 Extended Parameter Settings	47
Servo Amplifier	48
Safety remote I/O module	53
Writing extended parameters	57
2.8 Safety Function Cancel Program	59
2.9 Program Writing	60
2.10 Safety Parameter Settings Using MR Configurator2	64
Setting the servo amplifier safety parameters	64
Writing the safety parameter settings	69
2.11 Enabling the Safety Settings (Safety Remote I/O Module)	71
<b>CHAPTER 3 Operation Check</b>	<b>79</b>
3.1 Communication with the Safety Remote I/O Module	79
3.2 Checking that Safety Communication Settings were Completed Correctly	79
3.3 Safety Monitoring Operation Check	80
<b>CHAPTER 4 Troubleshooting</b>	<b>88</b>
4.1 Segment LED Displays and Contents	88
4.2 Errors and Corrective Actions	90
<b>CHAPTER 5 Switching Safety Operation Mode</b>	<b>91</b>
5.1 Safety operation mode	91

5.2	How to switch safety operation mode.....	91
5.3	Checking After Switching Safety Operation Mode.....	92
<b>Appendix</b>		<b>93</b>
<hr/>		
Appendix 1	Library Registration.....	93
Appendix 2	Sample Program .....	95
Appendix 3	Safety Remote Reset.....	107
REVISIONS	.....	111
TRADEMARKS	.....	112

# Servo Amplifier Characteristics

## Safety sub-functions

The MR-J5 servo amplifier includes safety sub functions.

However the achievable safety sub functions and safety level vary depending on the combination of servo amplifier and servo motor. Refer to the table below.

### ■ Safety sub-function compatibility list (servo amplifier firmware version: B2)

Servo amplifier model	Function delivery method (wiring connection)	Servo motor category	Safety sub-functions (IEC/EN 61800-5-2)				
			STO	SS1		SS2*3	SOS*3
				SS1-t	SS1-r*3	SS2-t, SS2-r	
MR-J5-G MR-J5-A(-RJ)	DI/O connection (CN8)	Servo motor supporting functional safety Rotary type servo motor Linear servo motor Direct drive motor	Cat. 3 PL e, SIL 3	—*8	—	—	—
MR-J5-G-RJ	DI/O connection*2*6 (CN8)	Servo motor supporting functional safety	Cat. 4 PL e, SIL 3	Cat. 4 PL e, SIL 3	Cat. 4 PL e, SIL 3	Cat. 4 PL e, SIL 3	Cat. 4 PL e, SIL 3
		Rotary type servo motor Linear servo motor Direct drive motor	Cat. 4 PL e, SIL 3	Cat. 4 PL e, SIL 3	Cat. 3 PL d, SIL 2	—	—
	Network connection*1*5*7 (CN1A/CN1B)	Servo motor supporting functional safety	Cat. 4 PL e, SIL 3	Cat. 4 PL e, SIL 3	Cat. 4 PL e, SIL 3	Cat. 4 PL e, SIL 3	Cat. 4 PL e, SIL 3
		Rotary type servo motor Linear servo motor Direct drive motor	Cat. 4 PL e, SIL 3	Cat. 4 PL e, SIL 3	Cat. 3 PL d, SIL 2	—	—
MR-J5W2-G*4 MR-J5W3-G*4	DI/O connection*2*6 (CN8)	Servo motor supporting functional safety Rotary type servo motor Linear servo motor Direct drive motor	Cat. 4 PL e, SIL 3	Cat. 4 PL e, SIL 3	—	—	—

Servo amplifier model	Function delivery method (wiring connection)	Servo motor category	Safety sub-functions (IEC/EN 61800-5-2)					
			SBC	SLS*3	SSM*3	SDI*3	SLI*3	SLT
MR-J5-G MR-J5-A(-RJ)	DI/O connection (CN8)	Servo motor supporting functional safety Rotary type servo motor Linear servo motor Direct drive motor	—	—	—	—	—	—
MR-J5-G-RJ	DI/O connection*2*6 (CN8)	Servo motor supporting functional safety	Cat. 4 PL e, SIL 3	Cat. 4 PL e, SIL 3	Cat. 4 PL e, SIL 3	Cat. 4 PL e, SIL 3	Cat. 4 PL e, SIL 3	Cat. 3 PL d, SIL 2
		Rotary type servo motor Linear servo motor Direct drive motor	Cat. 4 PL e, SIL 3	Cat. 3 PL d, SIL 2	Cat. 3 PL d, SIL 2	Cat. 3 PL d, SIL 2	—	Cat. 3 PL d, SIL 2
	Network connection*1*5*7 (CN1A/CN1B)	Servo motor supporting functional safety	Cat. 4 PL e, SIL 3	Cat. 4 PL e, SIL 3	Cat. 4 PL e, SIL 3	Cat. 4 PL e, SIL 3	Cat. 4 PL e, SIL 3	Cat. 3 PL d, SIL 2
		Rotary type servo motor Linear servo motor Direct drive motor	Cat. 4 PL e, SIL 3	Cat. 3 PL d, SIL 2	Cat. 3 PL d, SIL 2	Cat. 3 PL d, SIL 2	—	Cat. 3 PL d, SIL 2
MR-J5W2-G*4 MR-J5W3-G*4	DI/O connection*2*6 (CN8)	Servo motor supporting functional safety Rotary type servo motor Linear servo motor Direct drive motor	Cat. 4 PL e, SIL 3	—	—	—	—	—

\*1 Combine with a Safety CPU that has firmware version 20 or later.

\*2 The safety level indicated in the table is for a case when safety sub-function control is performed using a Safety CPU or safety controller that supports category 4 PL e, SIL 3. When directly connecting the emergency stop switch, safety switch, enable switch, or another switch to the servo amplifier, the safety level will be category 3 PL d, SIL 2.

\*3 A full-closed control system does not support SS1-r, SS2, SOS, SLS, SSM, SDI, or SLI.

\*4 The safety sub functions are supported by MR-J5W that were manufactured in or after November 2019. STO can be set for each axis.

\*5 Connect with a communications cycle of 125 μs or longer.

\*6 With a DI/O connection (CN8), diagnosis using a test pulse is required in order to satisfy category 4 PL e, SIL 3.

\*7 Safety sub functions using a network can only be used with MR-J5-G-RJ.

\*8 The combination of MR-J3-D05 and the servo amplifier supports SS1-t.

## Safety sub-functions conforming to IEC/EN 61800-5-2

The MR-J5-G-RJ supports the STO, SS1, SS2, SOS, SBC, SLS, SSM, SDI, SLI, and SLT safety sub-functions.

In this manual, SLS, SS1, and SDI are used.

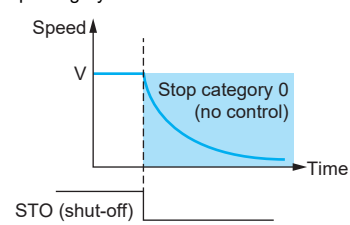
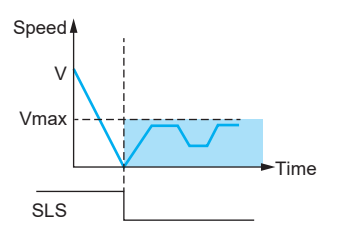
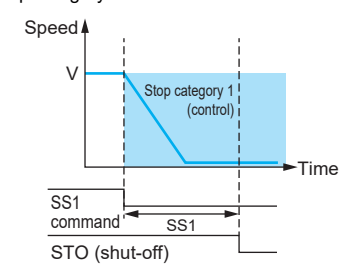
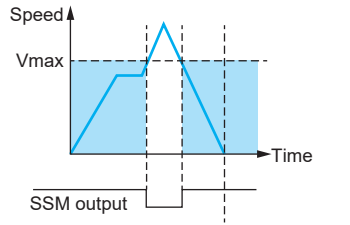
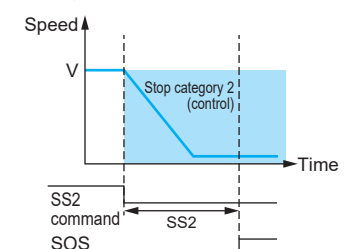
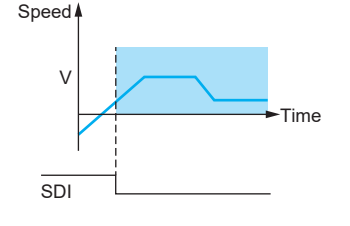
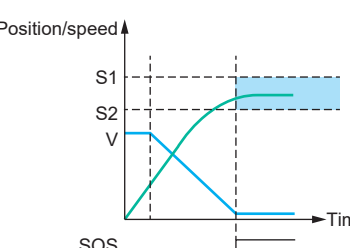
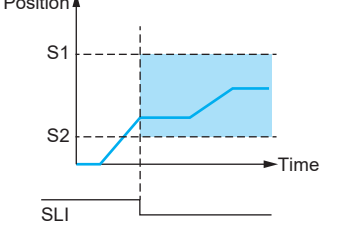
<p><b>Safe Torque Off (STO)</b></p> <p>Based on an input signal from an external device, the motor drive energy is electronically shut off. (Secondary side output shut-off) Corresponds to stop category 0 in IEC/EN 60204-1.</p>  <p>Be sure to only perform STO in servo-off state or after the servo motor stops.</p>	<p><b>Safety Limited Speed (SLS)</b></p> <p>This function monitors to prevent the prescribed speed limit value from being exceeded. If the prescribed speed limit value is exceeded, STO shuts off the energy.</p> 
<p><b>Safe Stop 1 (SS1)</b></p> <p>Starts deceleration based on an input signal from an external device. When the specified time that can confirm stop has elapsed, the STO function is executed. Deceleration monitoring based on the motor deceleration rate is also supported. Corresponds to stop category 1 in IEC/EN 60204-1.</p> 	<p><b>Safe Speed Monitor output (SSM)</b></p> <p>A safety output signal is output when the motor speed is within the specified speed.</p> 
<p><b>Safe Stop 2 (SS2)</b></p> <p>Starts deceleration based on an input signal from an external device. When the specified time that can confirm stop has elapsed, the SOS function is executed. Deceleration monitoring based on the motor deceleration rate is also supported. Corresponds to stop category 2 in IEC/EN 60204-1.</p> 	<p><b>Safe Direction limit (SDI)</b></p> <p>Monitors to ensure that the movement direction is the specified direction. If the direction changed, the STO function is executed.</p> 
<p><b>Safe Operating Stop (SOS)</b></p> <p>Monitors to ensure that the motor does not deviate from the stop position by more than the predetermined range. Energy is provided to the motor in this state.</p> 	<p><b>Safely Limited Increment (SLI)</b></p> <p>Monitors to ensure that the amount of movement does not exceed the prescribed range. If the range is exceeded, the STO function is executed.</p> 

**Safe Brake Control (SBC)**

A safety output signal is output for external brake control.

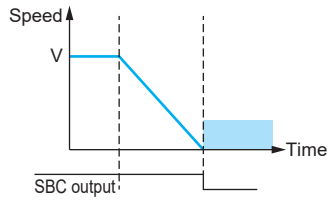
**Safely-Limited Torque (SLT)**

Monitors to ensure that the torque (or thrust) does not exceed the prescribed range.

If the range is exceeded, the STO function is executed.

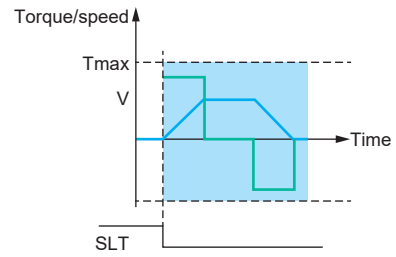

 : Function activation area

# Safety Communication Characteristics

The [Safety sub-function] which is a feature of the servo amplifier can use safety communication to perform control. Depending on the combination of the Safety CPU set and Motion module, it may be possible for the servo amplifier to receive safety signal data from the Safety CPU via the CC-Link IE TSN that is connected to the Motion module.

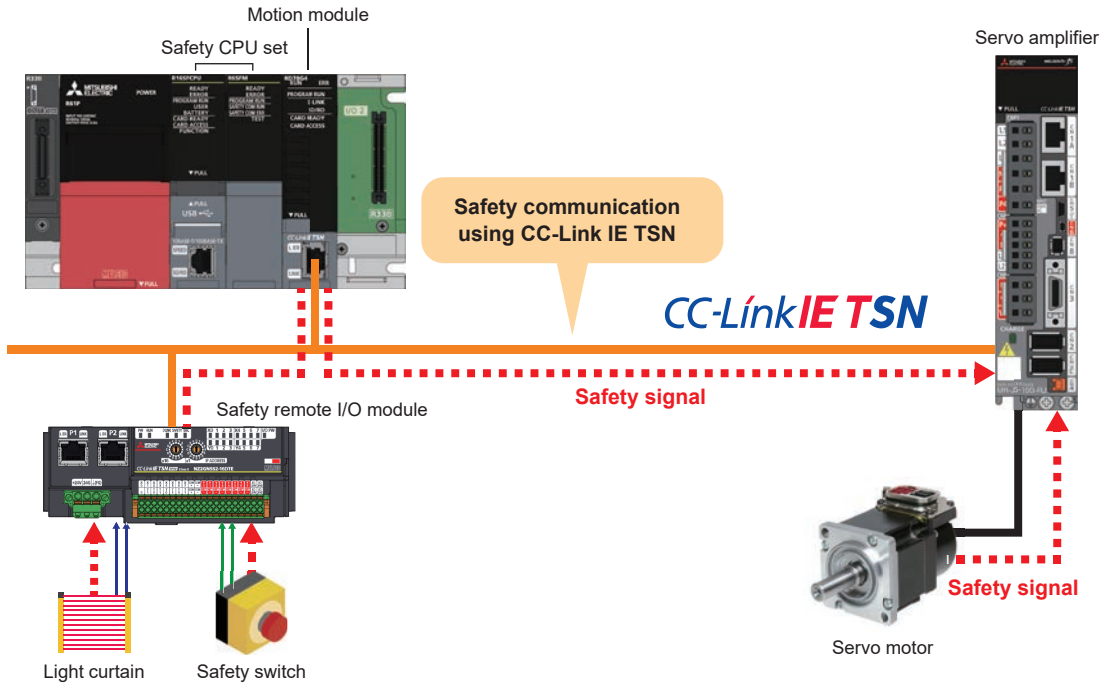

**Point**

Because it is possible to integrate general communication and safety communication using a single CC-Link IE TSN, it is possible to use both general remote I/O modules and safety remote I/O modules together.

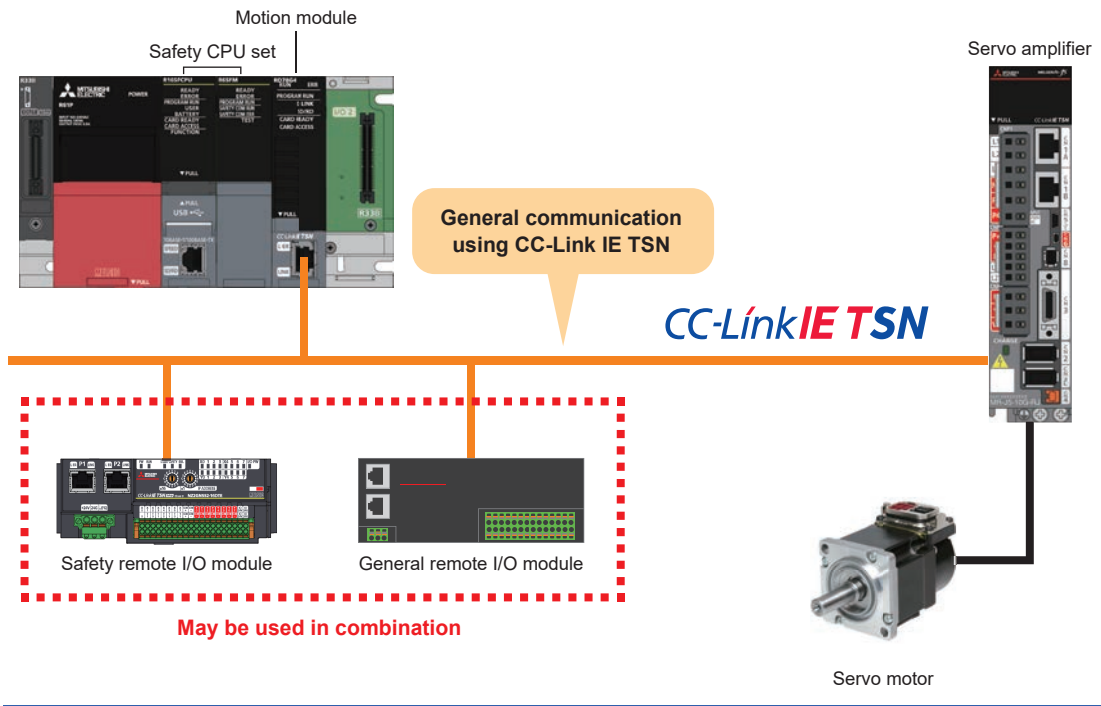

# System Configuration

This manual explains the following example of system configuration.

— : Ethernet cable

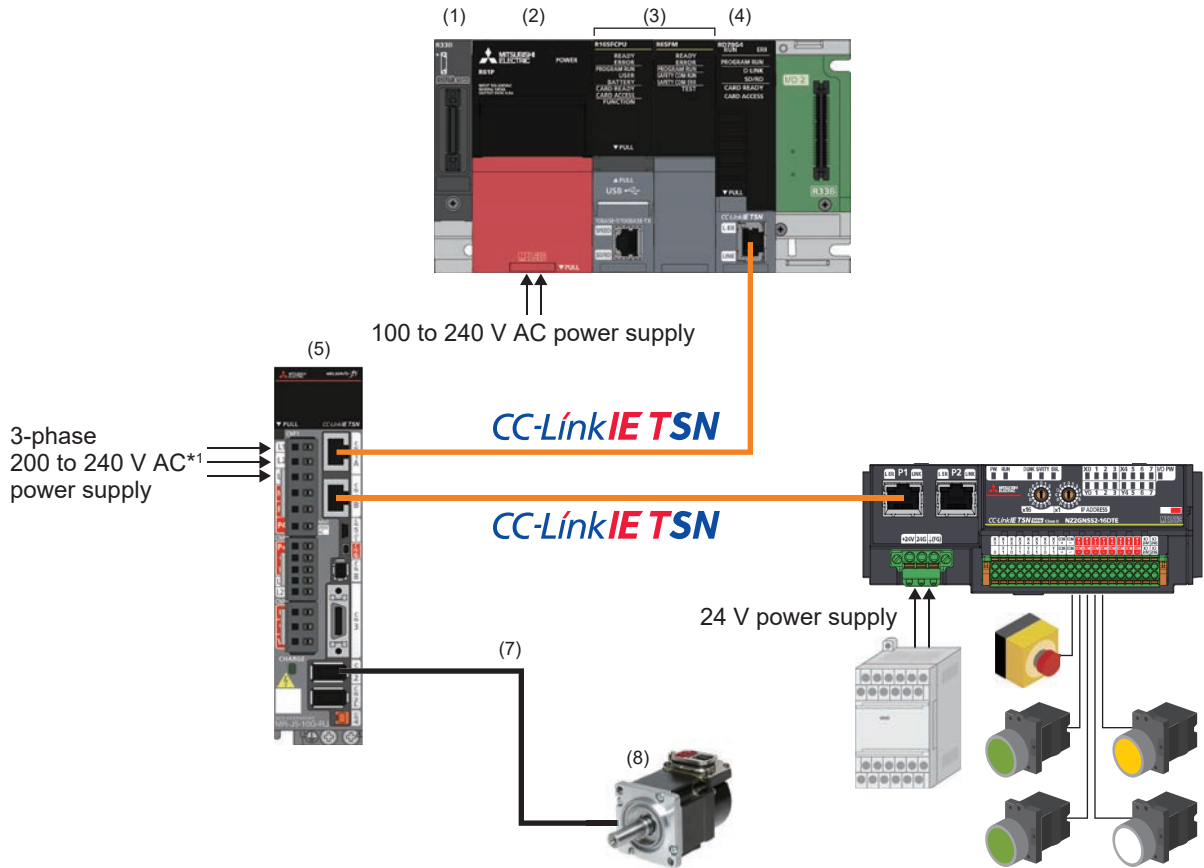

\*1 In the case of a single phase 200 to 240 V AC power supply, the power supply is connected to L1 and L3, and nothing should be connected to L2.

No.	Device name	Model
(1)	Main base unit	R33B
(2)	Power supply module	R61P
(3)	Safety CPU set <sup>*2</sup>	R16SFCPU-SET
(4)	Motion module	RD78G4
(5)	Servo amplifier	MR-J5-10G-RJ
(6)	Safety remote I/O module	NZ2GNSS2-16DTE
(7)	Motor cable (2 m)	MR-AEP2CBL2M-A1-H
(8)	Servo motor	HK-KT053WWS

\*2 Set consisting of R16SFCPU Safety CPU and R6SFM safety function module

# About the Tools Used

## GX Works3 (model: SW1DND-GXW3-E)

GX Works3 is an engineering tool that is used for configuring settings, programming, debugging, and maintenance of a programmable controller such as the MELSEC iQ-R series or MELSEC iQ-F series.

Connect the PC and Safety CPU with a USB cable, and set the motion and servo amplifier parameters (except the safety parameters).

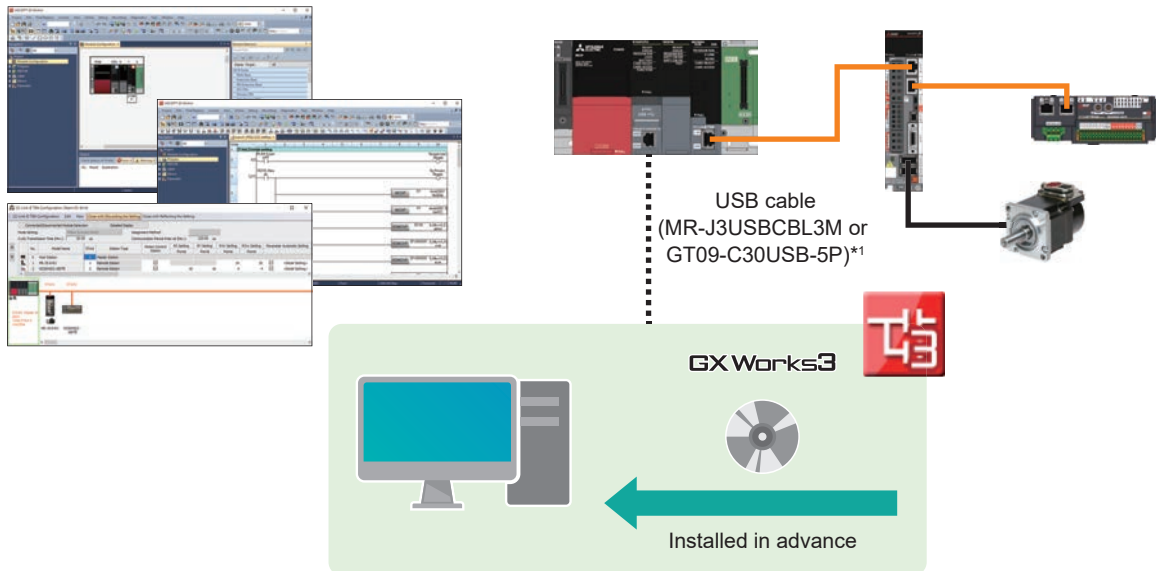

\*1 For other cables where operation has been verified, refer to the following.  
📖 GX Works3 Operating Manual

## MR Configurator2 (model: SW1DNC-MRC2-E)

MR Configurator2 is software that supports all phases from servo amplifier start-up to maintenance.

It can be used to change parameters, display graphs, perform program operation using a simplified language, perform test operation, and other tasks.

Connect the PC and servo amplifier with a USB cable, and set the servo amplifier safety parameters.

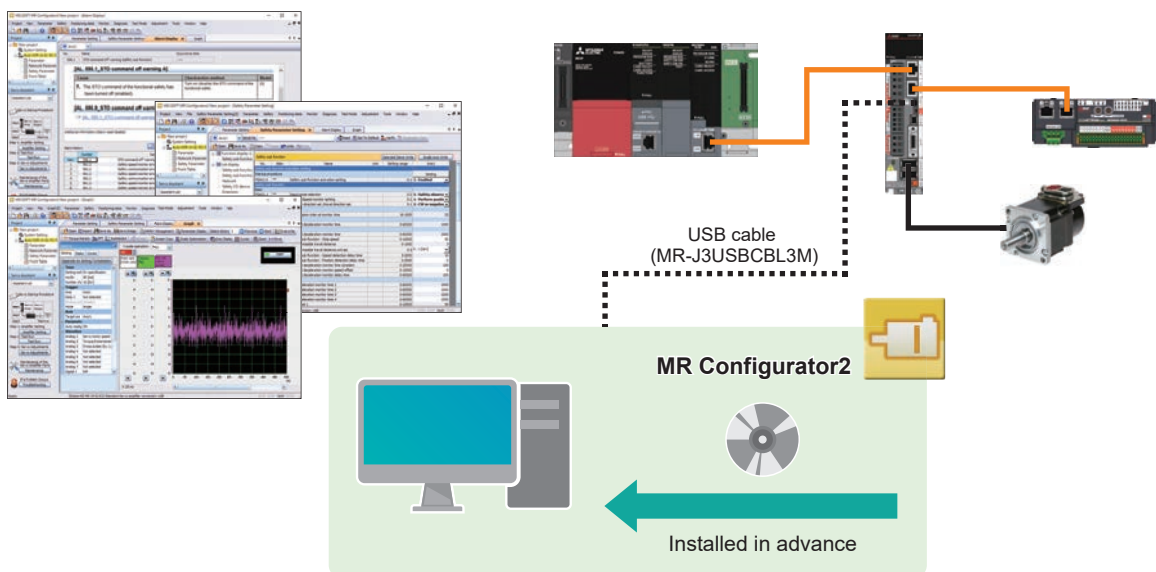

# Motion Setting Tool (model: SW1DNN-MUCNF-E)

Motion Setting Tool is software that performs setting and monitoring of the Motion module in combination with GX Works3.

## ■Motion Setting Tool download procedure

MITSUBISHI ELECTRIC FA Global Website top page

<https://www.mitsubishielectric.com/fa/>

Download → Software

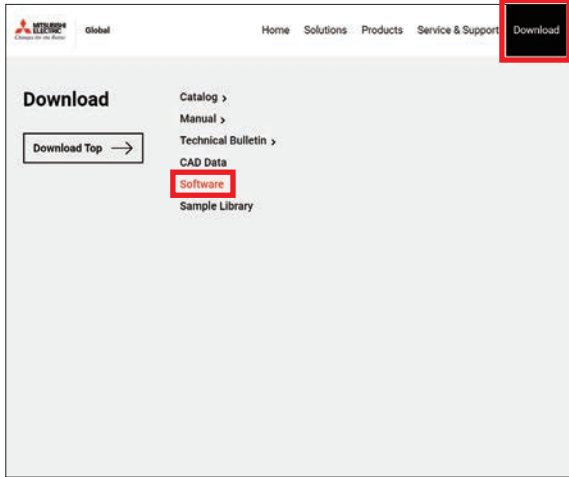

Please select the country/region where you currently live.

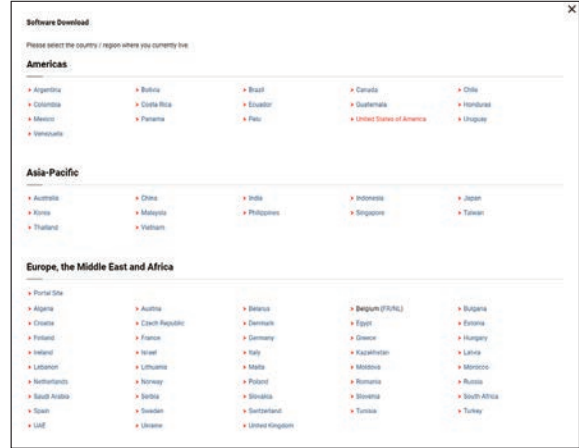

Servo & Motion Controllers → Motion Setting Tool (GX Works3 is Required)



- ▶ Servo & Motion Controllers
- ▶ A Motion Controller
- ▶ **Motion Setting Tool (GX Works3 is Required)**
- ▶ FX Configurator-PP
- ▶ MR Configurator2
- ▶ MR Configuration Setup 161E (J2S)
- ▶ MSIZE Servo Sizing
- ▶ Motorizer Servo Sizing (NEW 06/2023)
- ▶ PNMOT11\_3rd Party Motor Tool

# Setting Flow

Follow the procedure below and configure the safety communication settings before start-up.











	Page 14 Registering a Profile
	
	Page 19 Creating a Project (Page 19 Creating a New Project, Page 21 Programmable Controller Initialization, Page 23 Registering User Information, Page 24 Module Configuration)
	
	Page 28 Parameter Settings (Servo amplifier, safety remote I/O module)
	
	Page 39 Safety Communication Settings
	
	Page 47 Extended Parameter Settings (Servo amplifier, safety remote I/O module)
	
	Page 59 Safety Function Cancel Program
	
	Page 60 Program Writing
	
	Page 64 Safety Parameter Settings Using MR Configurator2 (Servo amplifier)
	
	Page 69 Writing the safety parameter settings
	
	Page 71 Enabling the Safety Settings (Safety Remote I/O Module)

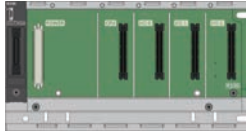

 : GX Works3     : MR Configurator2

# 1 Preparation

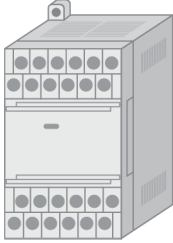
## 1.1 Devices to Prepare

Prepare the following devices.

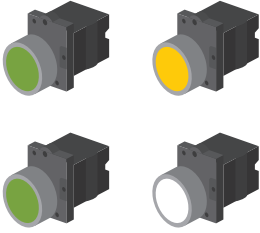
<b>Safety CPU set</b>		<b>Power supply module (1)</b>	<b>Main base unit (1)</b>
<b>Safety CPU (1)</b>	<b>Safety function module (1)</b>		
 <p>R16SFCPU Firmware version 21 or later</p>	 <p>R6SFM</p>	 <p>R61P</p>	 <p>R33B</p>
<b>Motion module (1)</b>	<b>Safety remote I/O module (1)</b>	<b>Servo amplifier (1)</b>	<b>Servo motor (1)</b>
 <p>RD78G4 baseSystem: Ver. 1.8 or later NetworkDriver_CCIETSN: Ver. 1.7 or later</p>	 <p>NZ2GNSS2-16DTE</p>	 <p>MR-J5-10G-RJ</p>	 <p>HK-KT053WWS</p>
<b>Motor cable (1)</b>	<b>Ethernet cables (2)</b>	<b>Power supply (24 V)</b>	<b>Emergency stop switch (1)</b>
 <p>MR-AEP2CBL2M-A1-H (2 m)</p>	<p>Prepare a category 5e or above (double-shielded, STP) straight cable that satisfies one of the standards below.</p> <ul style="list-style-type: none"> <li>• IEEE802.3 (1000BASE-T)</li> <li>• ANSI/TIA/EIA-568-B (Category 5e)</li> </ul> 	<p>Prepare a power supply with input 100 to 200 V AC, output 24 V DC, and capacity 1 A or more.</p>  <p>Purpose: Power supply for safety remote I/O module</p>	<p>Prepare normally closed twin contacts.</p>  <p>Purpose: For emergency stop</p>

Switches (4)	PC (1)	USB cables for PC connection (iQ-R CPU module ↔ PC) (Servo amplifier ↔ PC)
<p>Prepare a momentary type with normally open single contact.</p>  <p>Purpose: Starting operation (forward, reverse), acceleration, reset</p>	 <p>GX Works3: Supports RD78G safety communication function with Ver. 1.065T (Motion Control Setting). MR Configurator2: Supports MR-J5-G safety functions with Ver. 1.110Q.</p>	 <p>When connecting iQ-R CPU module ↔ PC USB cable confirmed to operate correctly</p> <ul style="list-style-type: none"> <li>• MR-J3USBCBL3M (Mitsubishi Electric Corporation)</li> <li>• GT09-C30USB-5P (Mitsubishi Electric System &amp; Service Co., Ltd.)</li> </ul> <p>When connecting servo amplifier ↔ PC USB cable confirmed to operate correctly</p> <ul style="list-style-type: none"> <li>• MR-J3USBCBL3M (Mitsubishi Electric Corporation)</li> </ul>

## 1.2 Registering a Profile

The “Safety remote I/O module” and “Servo amplifier” profiles are used with GX Works3 [CC-Link IE TSN Configuration Settings].

Please consult your local Mitsubishi Electric representative.

### Operating procedure

This explains how to register a profile using GX Works3.

Before registering a profile, close all other projects.

1. From [Tool] on the menu bar, select [Profile Management] ⇒ [Register].

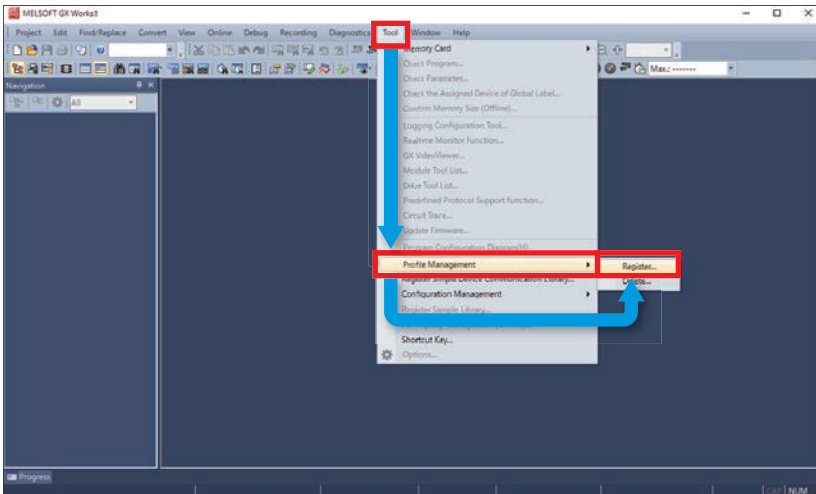

2. Select the profile to register and click [Register].

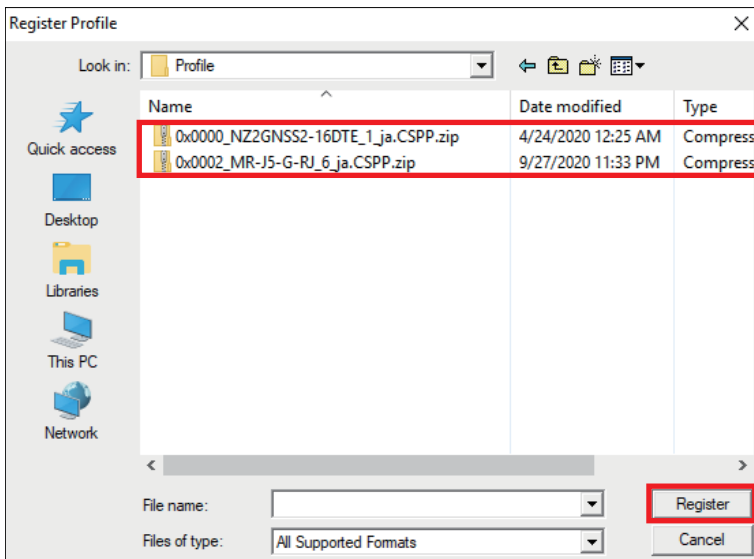

3. Click [OK].

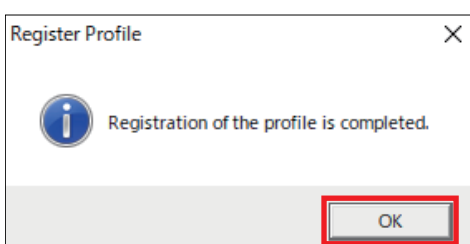

# 1.3 Wiring

This explains an example of the wiring.

## CC-Link IE TSN wiring

The CC-Link IE TSN wiring is as shown below.

The master station is the Motion module (STA#0) and the device modules are the servo amplifier (STA#1) and safety remote I/O module (STA#2).

The safety remote I/O module (NZ2GNSS2-16DTE) includes connectors P1 and P2. Although both connectors can be used, this manual explains the connection to P1.

In this manual, the modules are connected in a line type. They can be connected without using a TSN HUB.

— : Ethernet cable

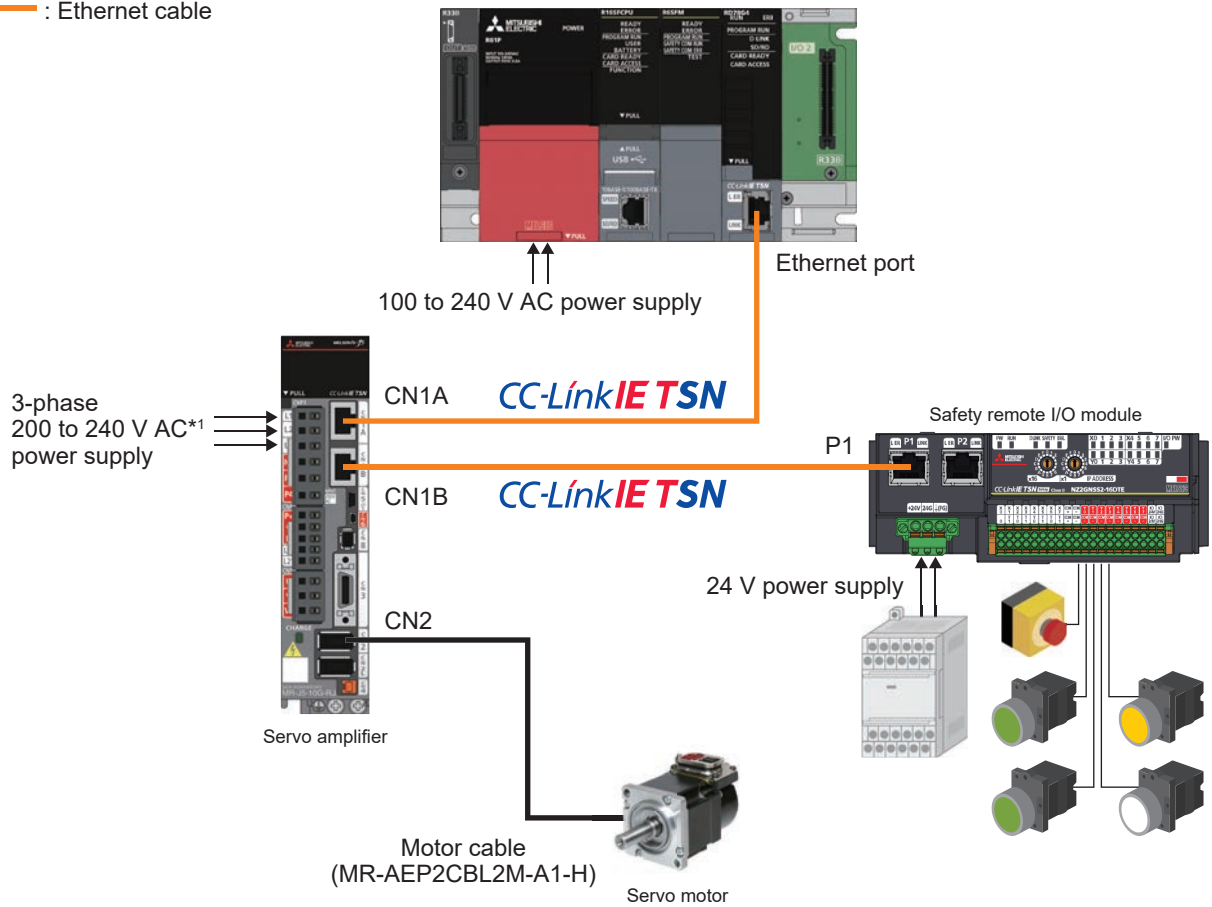

\*1 In the case of a single phase 200 to 240 V AC power supply, the power supply is connected to L1 and L3, and nothing should be connected to L2.

Refer to the following for an example of connecting the power supply circuit when using DC input.

MR-J5 User's Manual (Hardware)

## Safety remote I/O module wiring

The safety remote I/O module includes “I/O terminal block” and “Unit power supply/FG terminal block” connectors, and the specifications of the cables used are different. The processing of the cable ends is the same in all cases.

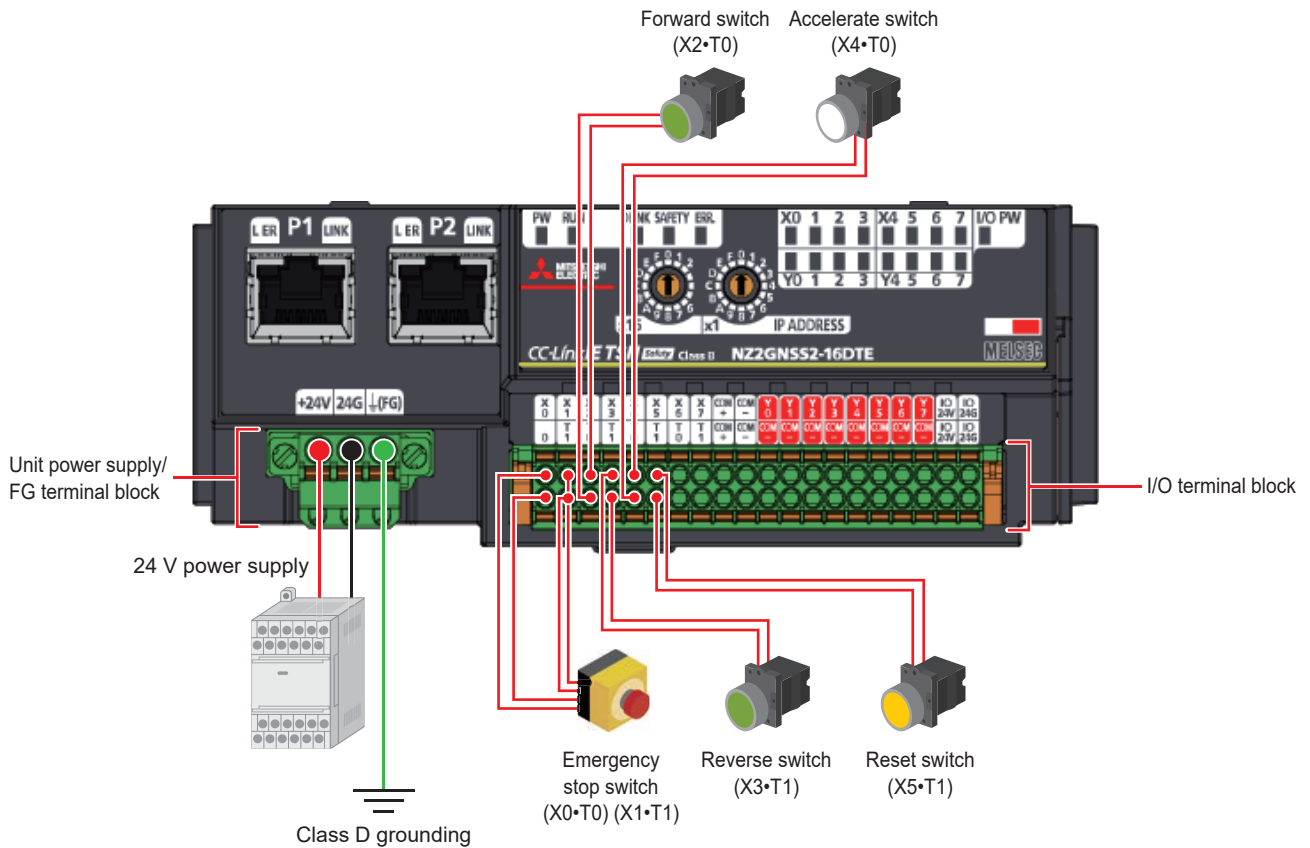

Refer to the following for wiring details.

📖 [CC-Link IE TSN Remote I/O Module \(With Safety Functions\) User's Manual](#)

## Precautions for servo amplifier wiring

When connecting wiring to the servo amplifier, supply power correctly to the locations shown below.  
Refer to the following for cable standards, cable sizes, and details of the wiring method.

📖 MR-J5 User's Manual (Hardware)

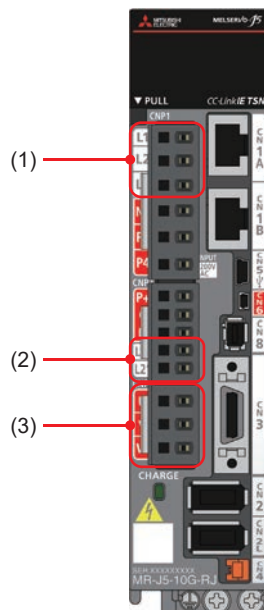

- (1) L1, L2, L3 (main circuit power supply): Connect the input power supply (3-phase 200 to 240 V AC).
- (2) L11, L21 (control circuit power supply): Connect the control circuit power supply and regenerative option.
- (3) U, V, W (servo motor power supply output): Connect the servo motor.

# MEMO

---

# 2 Creating a Project

## 2.1 Creating a New Project

Create a GX Works3 project.

### Operating procedure

1. Create a project.

[Project] ⇒ [New]

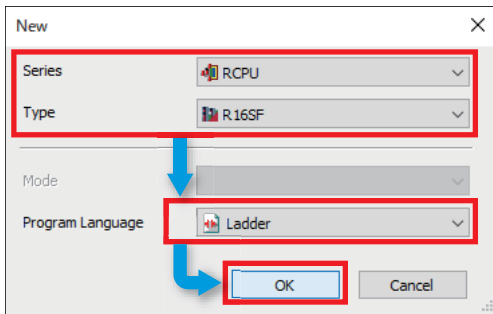

Item	Setting
Series	RCPU
Type	R16SF
Program Language	Ladder

2. The window shown below appears. Click [OK].

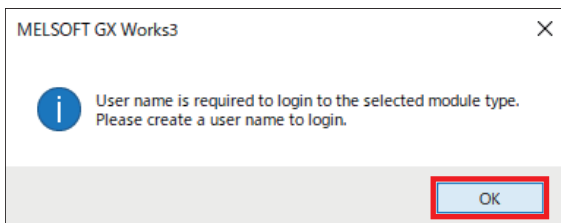

3. Enter the desired [User Name], [Password], and [Re-enter Password], then click [OK]. In this manual, “melsec” is used for both [User Name] and [Password].

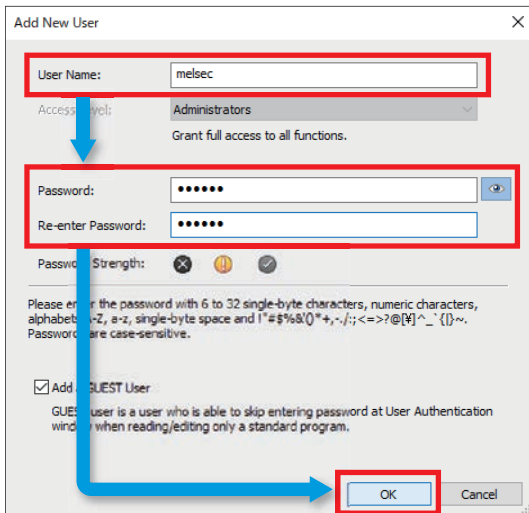

### Point

- Enter a password that is six 1-byte characters or more.
- Because the user name and password are used for subsequent settings, make a note of them so that you do not forget them.

4. The [Save as] window appears. Enter the desired file name and click [Save]. Here, we enter “Sample.”

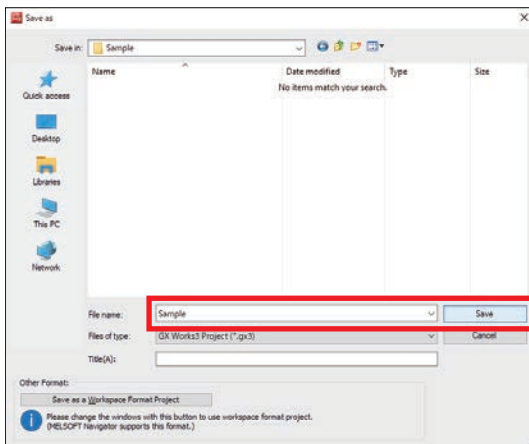

5. If the window shown below appears, click [OK].

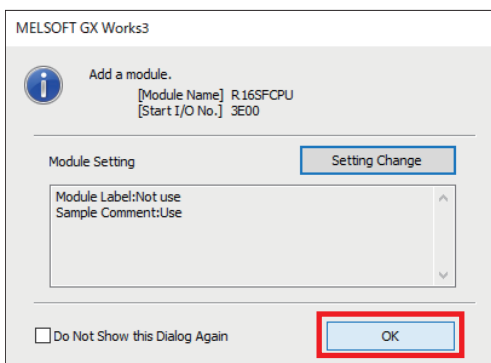

## 2.2 Programmable Controller Initialization

Initialize all programmable controller information. The operations and settings hereafter described must be performed with the PC and CPU module connected.

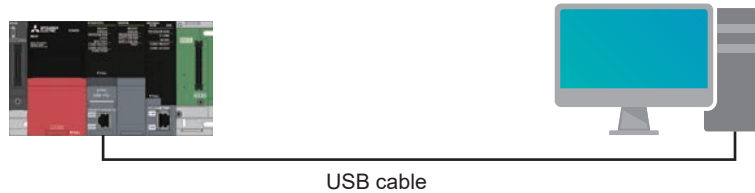

2

### Point

- Stop the CPU module.
- Connect the CPU module and PC using the USB cable.
- Set the GX Works3 connection destination setting to USB.

### Operating procedure

#### 1. Perform initialization.

[Online] ⇒ [User Authentication] ⇒ [Initialize all PLC Data]

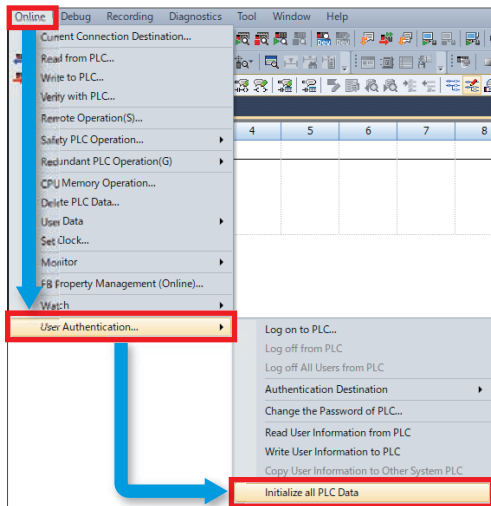

#### 2. A confirmation window appears. Click [Yes].

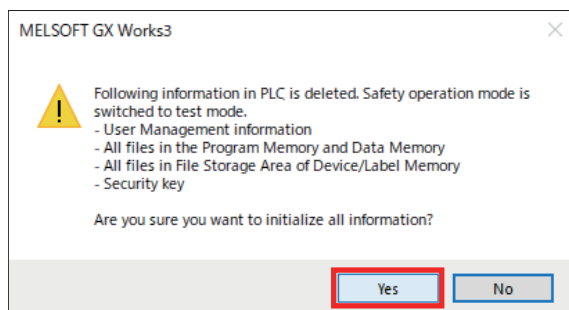

3. A second confirmation window appears. Click [Yes].

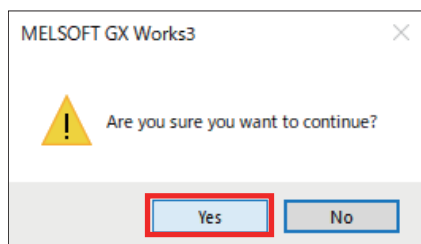

4. Click [OK].

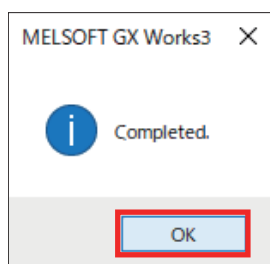

## 2.3 Registering User Information

The user information which is registered in a project is written to the CPU module.

### Operating procedure

1. Perform writing of user information to the programmable controller.

 [Online] ⇒ [User Authentication] ⇒ [Write User Information to PLC]

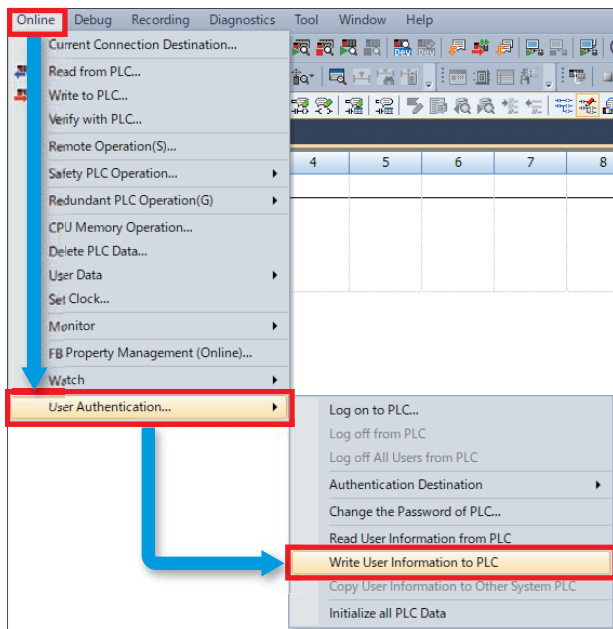

2. A confirmation window appears. Click [Yes].

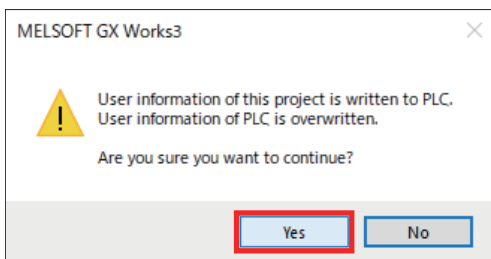

3. Click [OK].

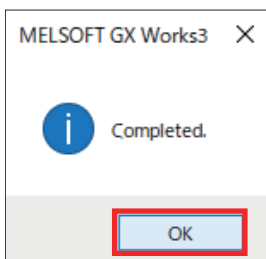

## 2.4 Module Configuration

The module configuration is defined according to the system configuration which is actually used. For details of the system configuration, refer to “[Page 8 System Configuration.](#)”

### Operating procedure

1. Display the module configuration.

Navigation window ⇒ Double-click [Module Configuration]

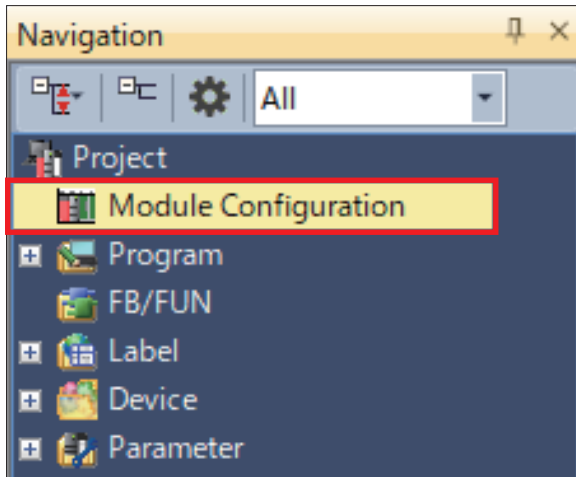

2. If the window shown below appears, click [OK].

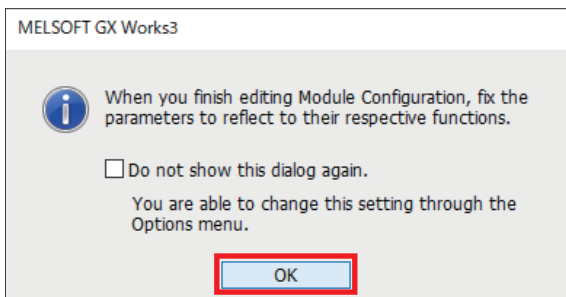

3. From the [Element Selection] window, drag & drop the following modules into the module configuration.

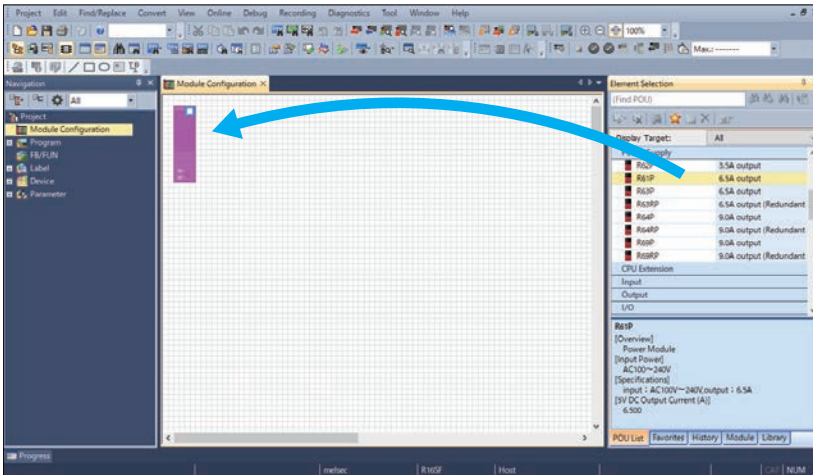

Category	Model
Safety CPU	R16SFCPU*1
CPU Extension	R6SFM
Power Supply	R61P
Main base	R33B
Motion Module	RD78G4

\*1 This is the CPU module that was selected at the time the new project was created, and is displayed from the beginning in the module configuration.

**Point**

Perform the operation below to change the display in the [Element Selection] window.  
 [View] ⇒ [Docking Window] ⇒ [Element Selection]

4. Place the modules as shown below.

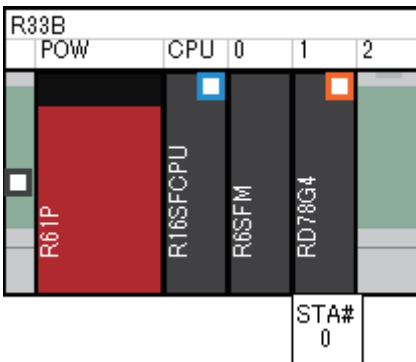

**Point**

Perform the operation below to change the module name display.  
 [Edit] ⇒ [Display Module Information]

5. Check the module configuration.

Right-click in the module configuration. ⇒ [Check] ⇒ [System Configuration]

6. Click [OK].

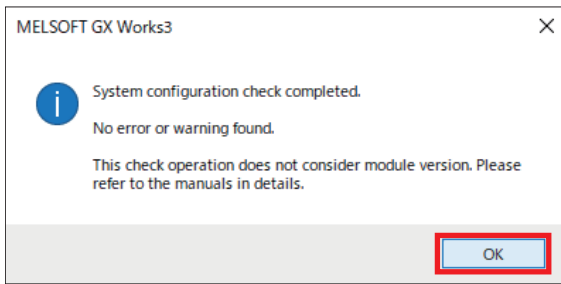

7. Confirm the module configuration.

Right-click in the module configuration ⇒ [Parameter] ⇒ [Fix]

8. A confirmation window appears. Click [Yes].

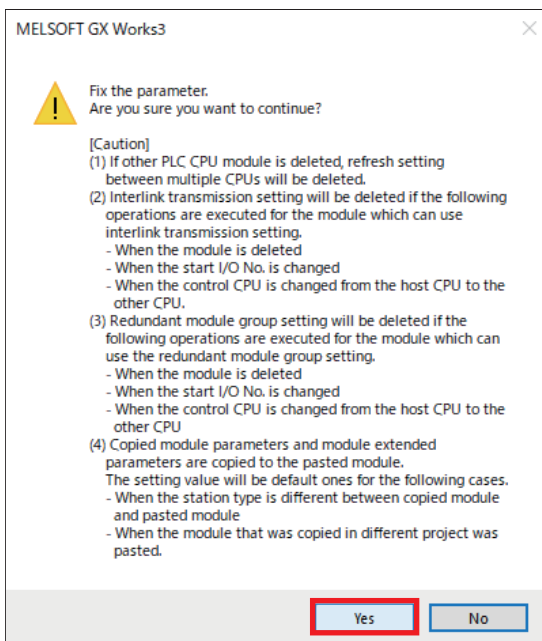

9. The following window appears. Click [Yes].

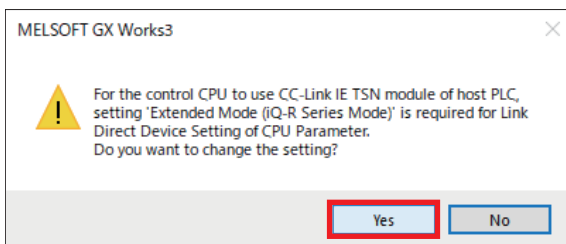

10. If the window shown below appears, click [OK].

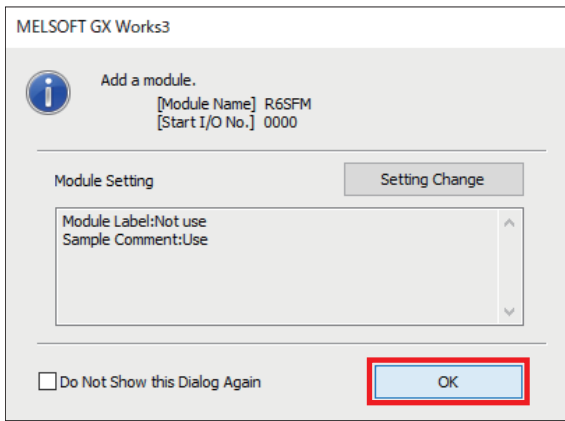

11. If the window shown below appears, click [OK].

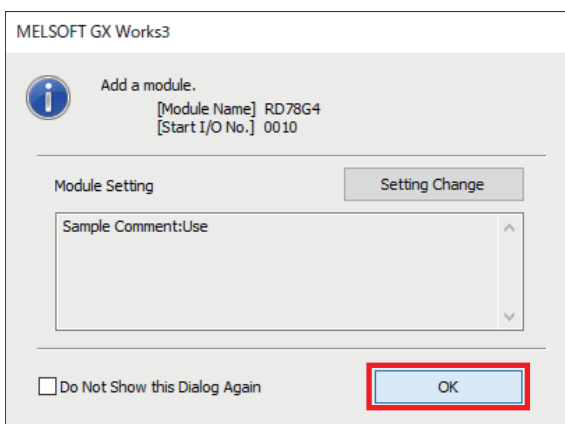

## 2.5 Parameter Settings

### Network configuration settings

Set the network configuration of the Motion module (RD78G4).

#### Precautions

The settings introduced in this section are an example. When using with an actual system, give sufficient consideration to ensure that there are no problems with control in that system.

For details of the parameters, refer to the following manuals.

📖 MELSEC iQ-R Motion Module User's Manual (Application)

📖 MELSEC iQ-R Motion Module User's Manual (Network)

📖 MR-J5-G/MR-J5W-G User's Manual (Parameters)

#### Operating procedure

1. Display the module parameters.

🖱️ Navigation window ⇒ [Parameter] ⇒ [Module Information] ⇒ [RD78G4] ⇒ Double-click [Module Parameter (Network)]

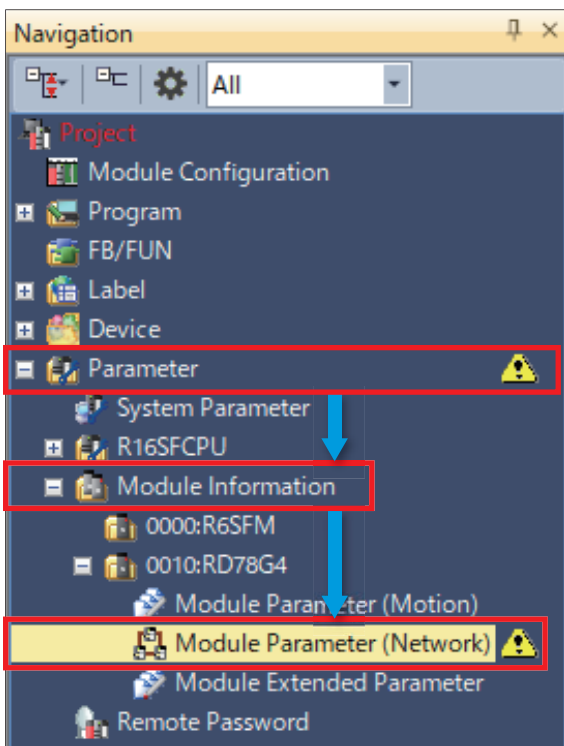

## 2. Set the communication period interval.

[Basic Settings] ⇒ [Communication Period Setting] ⇒ [Communication Period Interval Setting (Do not Set it in Units of 1μs)]

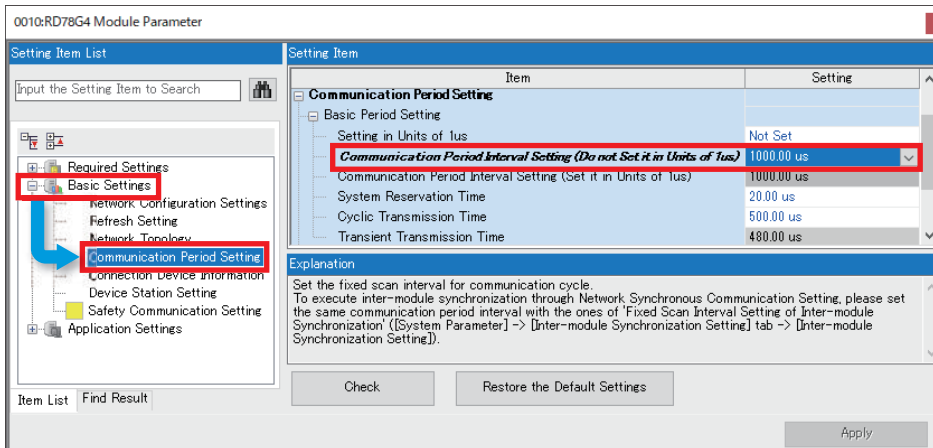

Item	Setting
[Communication Period Interval Setting (Do not Set it in Units of 1μs)]* <sup>1</sup>	1000.00 μs (default)

\*1 Refer to the following for details of the communication period setting.  
 MELSEC iQ-R CC-Link IE TSN User's Manual (Application)

## 3. Display the network configuration settings.

[Network Configuration Settings] ⇒ Double-click [Detailed Setting]

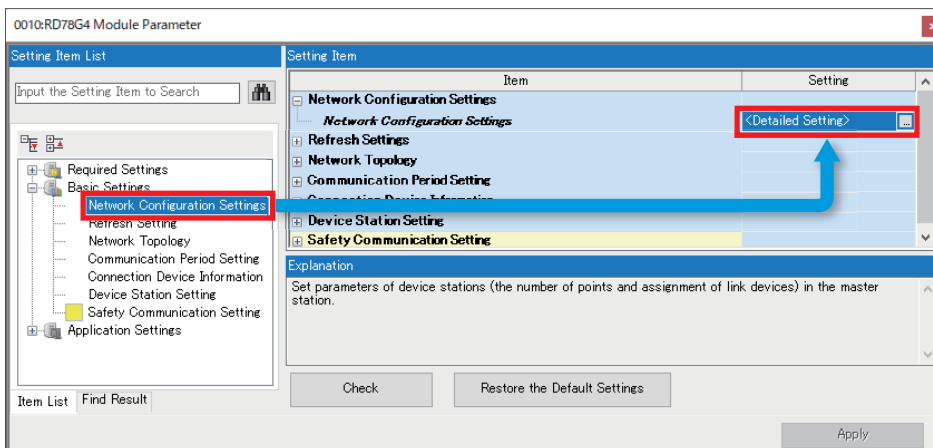

4. From the [Module List], select the following modules and drag & drop them into the configuration.

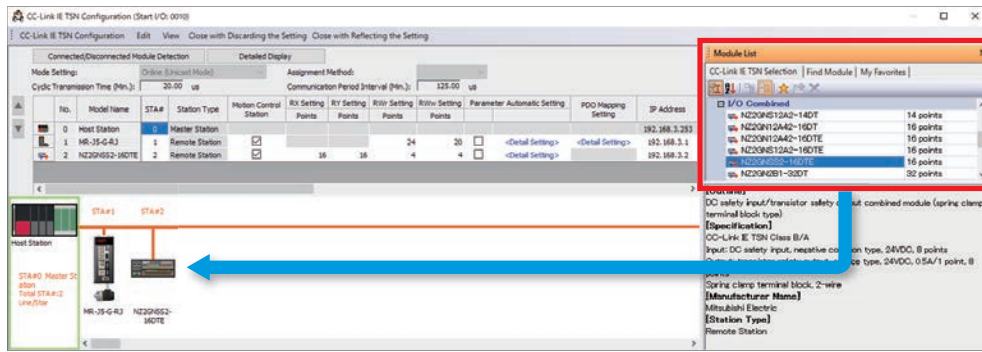

Category	Module name
General Purpose AC Servo	MR-J5-G-RJ
I/O Combined	NZ2GNSS2-16DTE

**Point**

- Perform the following operation to change the display in the [Module List] window.  
[View] ⇒ [Docking Window] ⇒ [Module List]
- If a module is not displayed, profile registration is necessary. For details, refer to “[Page 14 Registering a Profile.](#)”

5. The modules are as shown below.

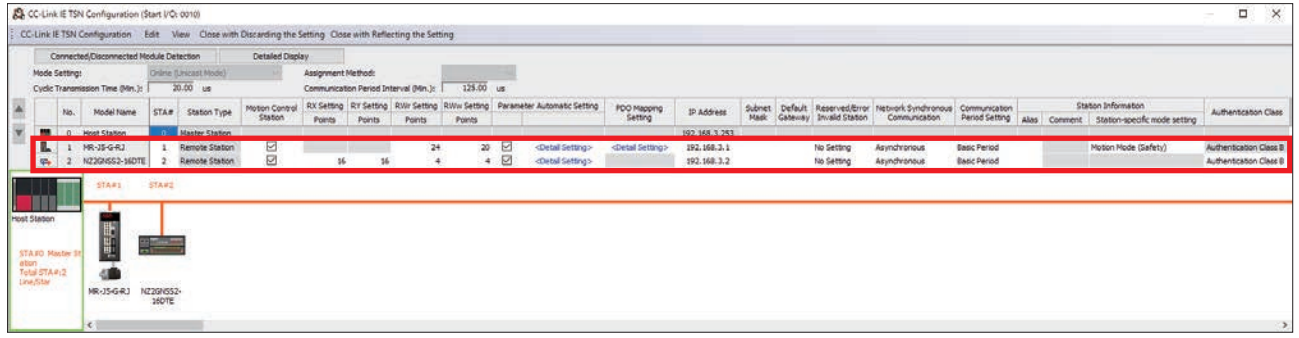

Item	Setting	
	MR-J5-G-RJ	NZ2GNSS2-16DTE
STA#	1	2
Motion Control Station	Checked	Checked
RX Setting	—	16
RY Setting	—	16
RWR Setting	24	4
RWw Setting	20	4
Parameter Automatic Setting <sup>*1</sup>	Checked	Checked
Station-specific mode setting	Motion Mode (Safety)	—

\*1 When the [Parameter Automatic Setting] checkbox is checked, the parameters set in the detailed settings are automatically transferred to the target unit when the CPU module power is turned OFF to ON.

6. Set PDO mapping.

[CC-Link IE TSN Configuration] ⇒ [Batch Setting of PDO Mapping]

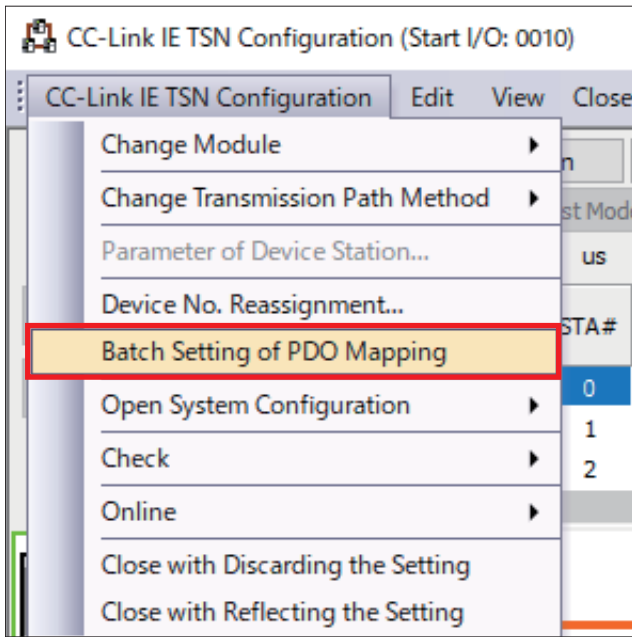

7. Click [Yes].

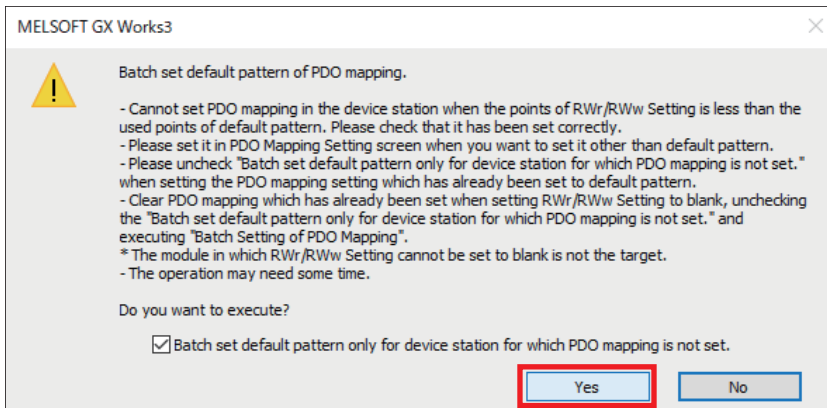

8. Click [OK].

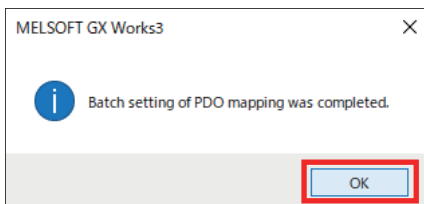

# Servo Amplifier

Set the other servo parameters.

## Operating procedure

1. Configure the settings in the [CC-Link IE TSN Configuration] window.

[MR-J5-G-RJ] ⇒ [Parameter Automatic Setting] ⇒ Double-click [<Detail Setting>]

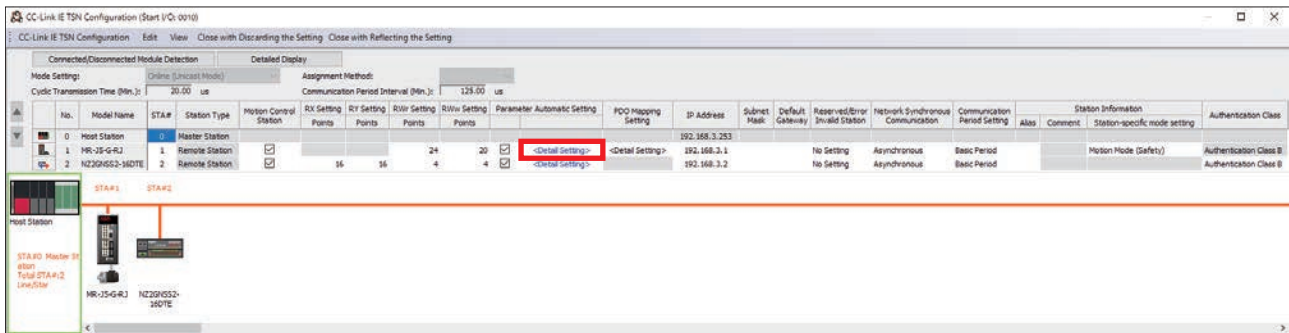

2. The following window appears. Click [Yes].

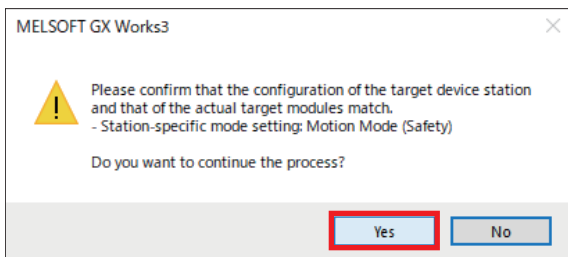

3. If the window shown below appears, click [OK].

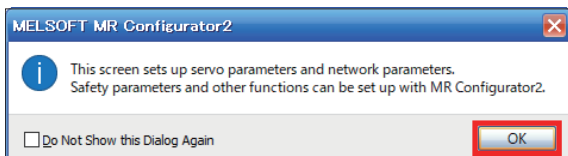

4. MR Configurator2 starts. Set the parameters according to the system control.

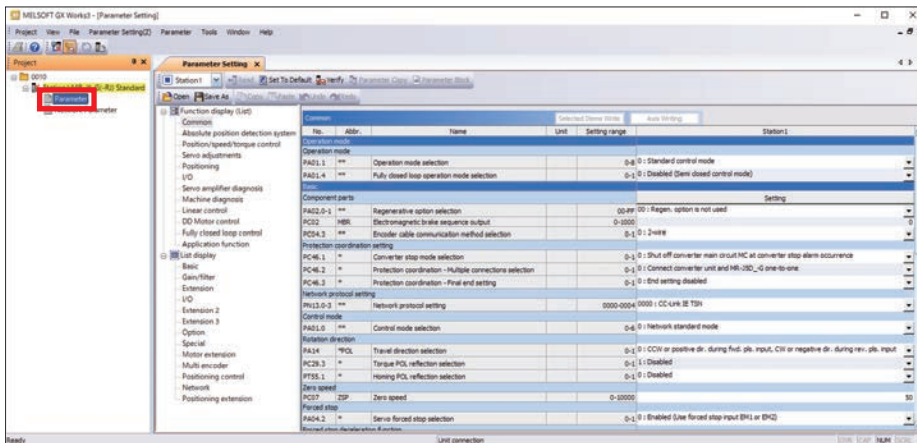

2

5. In this manual, because servo forced stop input EM2 and EM1 are not used, the following is set.

[Function display (List)] ⇒ [Common]

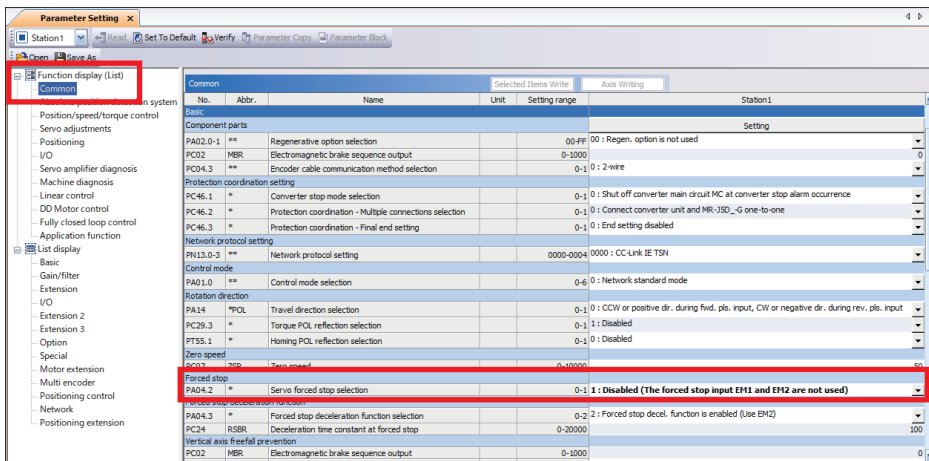

No.	Abbr.	Name	Setting
PA04.2	*	Servo forced stop selection	1: Disabled (The forced stop input EM1 and EM2 are not used)

Precautions

When directly wiring forced stop to the servo amplifier, set PA04.2 to [0: Enabled].

6. In this manual, because external input signals are not used for forward stroke end (LSP) and reverse stroke end (LSN), the following is set.

 [Function display (List)] ⇒ [I/O]

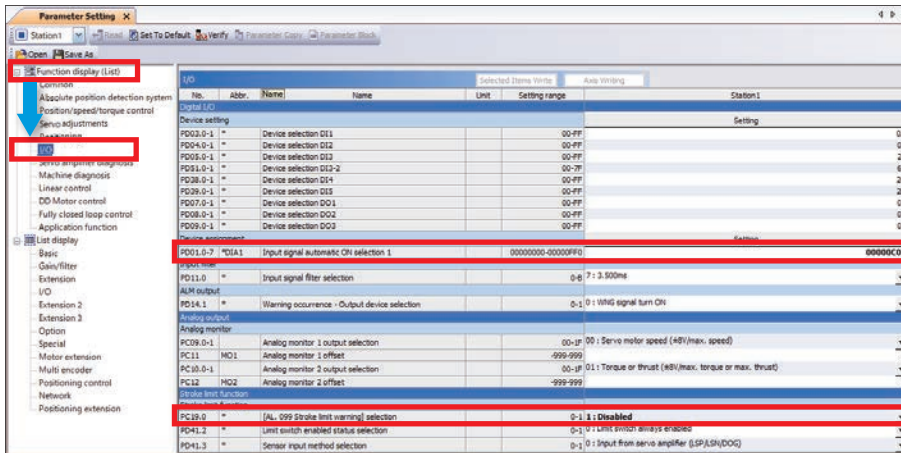

No.	Abbr.	Name	Setting
PD01.0-7	*DIA1	Input signal automatic ON selection 1	00000C00
PC19.0	*	[AL. 099 Stroke limit warning] selection	1: Disabled

7. Click the [×] button at the top right of the MR Configurator2 window to close the window.

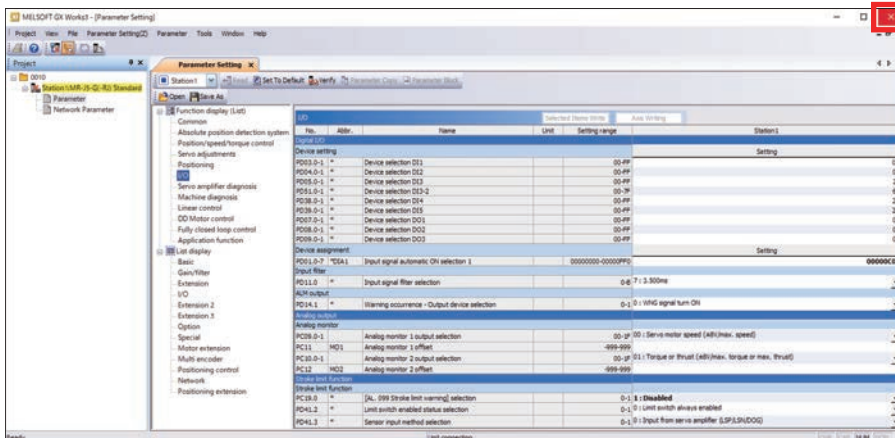

8. Click [Yes].

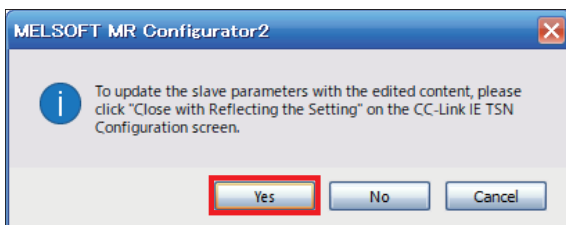

# Parameter settings (safety remote I/O module)

Save the parameters of the safety remote I/O module in the master station, and configure the parameters that are automatically set when connection or reconnection occurs as a result of safety remote I/O module power ON or other reason.

## Operating procedure

1. Configure the detailed settings for the safety remote I/O module.

[N2ZGNSS2-16DTE] ⇒ [Parameter Automatic Setting] ⇒ Double-click [<Detail Setting>]

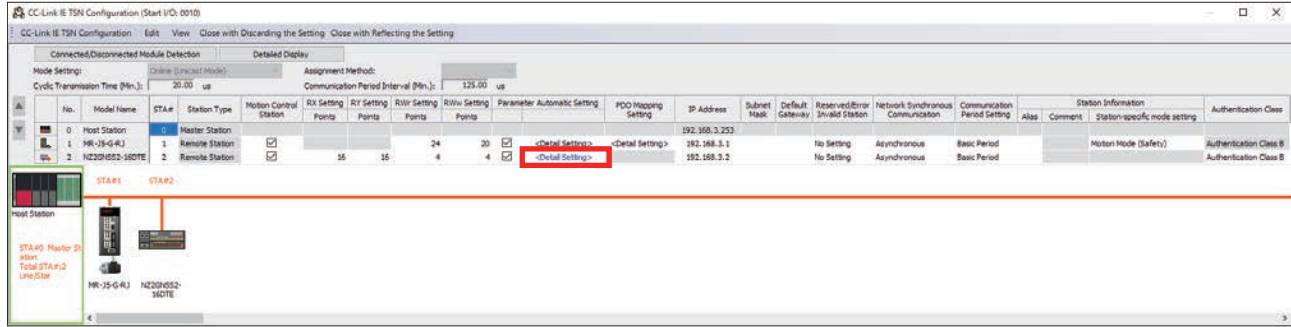

2. Click [OK].

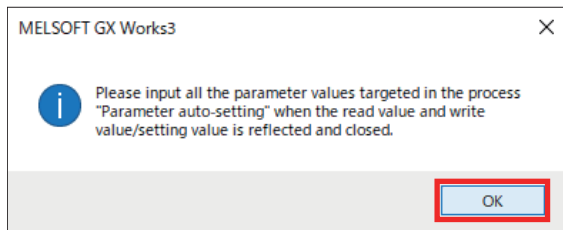

3. Select [Parameter auto-setting] for [Method selection], and click [Copy "Initial Value" to "Write Value/Setting Value"].

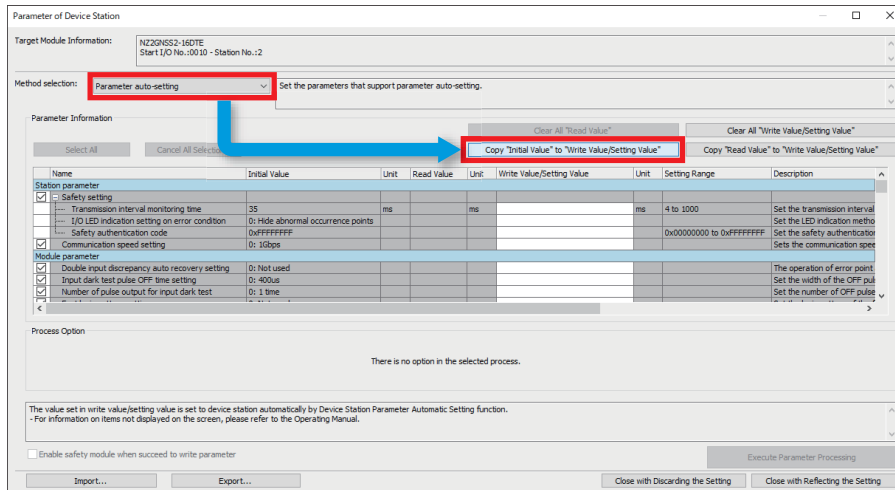

4. Click [Yes].

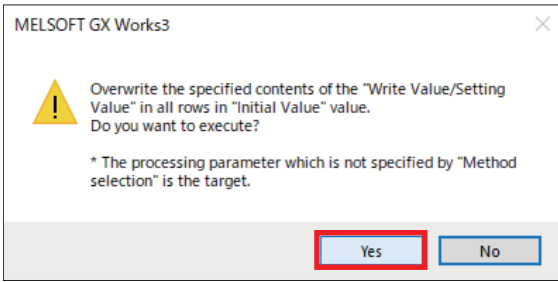

5. Set the transmission interval monitoring time. In this manual, the following value is set.

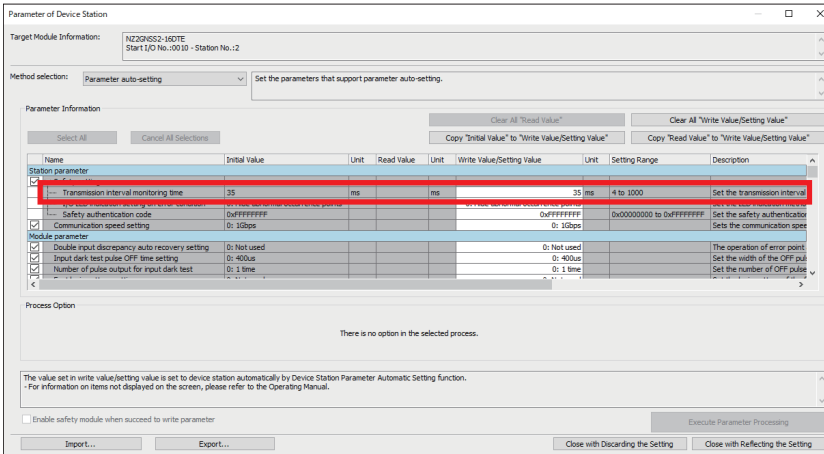

Name	Write Value/Setting Value
Transmission interval monitoring time*1	35 (default)

\*1 For details of the transmission interval monitoring time, refer to "Page 46 Monitoring time for safety communication."

## 6. Set the type of input wiring that is connected to the NZ2GNS2-16DTE.

The screenshots show the 'Parameter of Device Station' window for NZ2GNS2-16DTE. The 'Method selection' is set to 'Parameter auto-setting'. The 'Parameter Information' table lists various parameters, with the 'Wiring selection of input' parameters highlighted in red. The 'Write Value/Setting Value' column shows the selected wiring type for each input.

2

Name	Write Value/Setting Value
Wiring selection of input X0	1: Safety double wiring (NC/NC)
Wiring selection of input X1	1: Safety double wiring (NC/NC)
Wiring selection of input X2	3: General single
Wiring selection of input X3	3: General single
Wiring selection of input X4	3: General single
Wiring selection of input X5	3: General single

**7. Click [Close with Reflecting the Setting].**

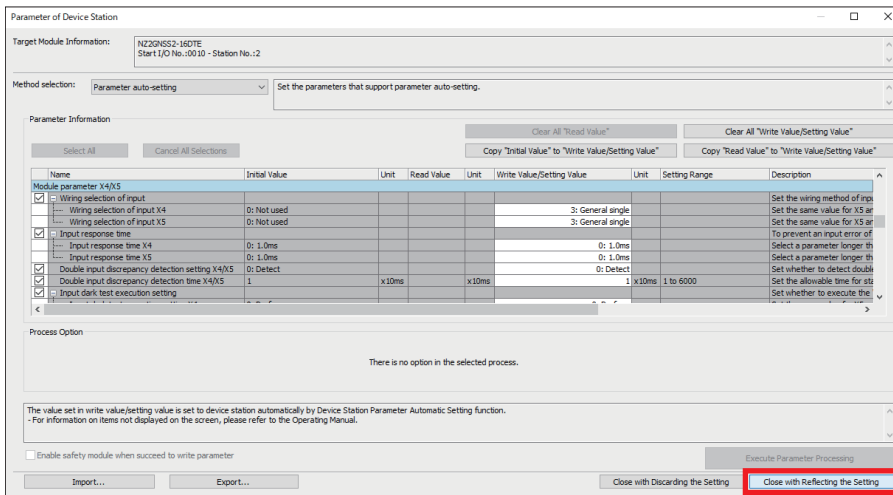

**8. Click [Close with Reflecting the Setting].**

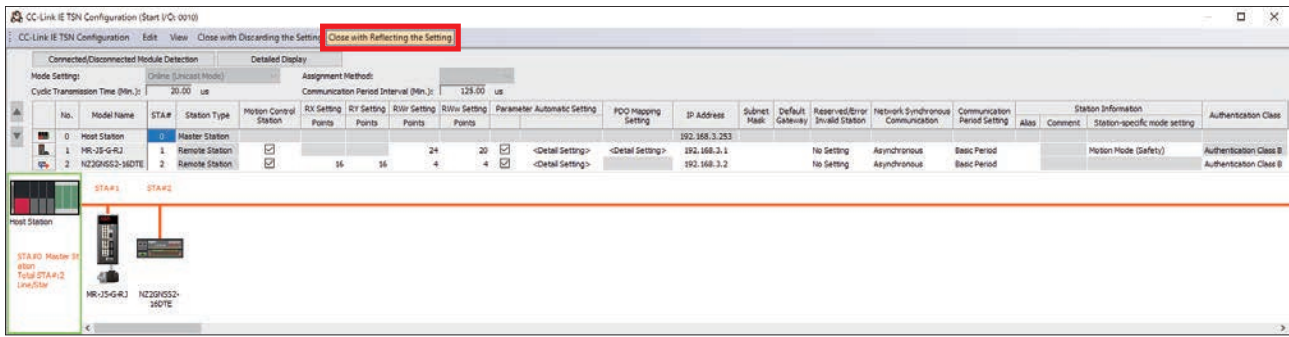

**9. If the window shown below appears, click [Yes].**

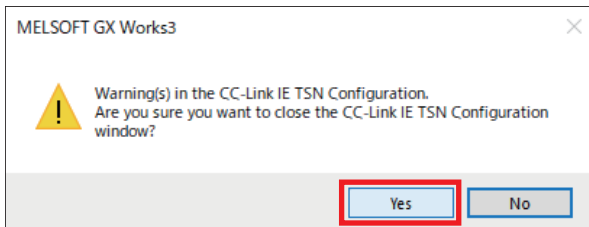

# 2.6 Safety Communication Settings

Configure the settings necessary for safety communication.

## Precautions

The settings introduced in this section are an example. When using with an actual system, give sufficient consideration to ensure that there are no problems with control in that system.

For details of the parameters, refer to the following manuals.

📖 MELSEC iQ-R Motion Module User's Manual (Application)

📖 MELSEC iQ-R Motion Module User's Manual (Network)

📖 MR-J5-G/MR-J5W-G User's Manual (Parameters)

## Safety function setting

Set the safety I/O and the timing for executing the safety program (Safety Cycle Time).

### Operating procedure

🖱️ Navigation window ⇒ [Parameter] ⇒ [R16SFCPU] ⇒ [CPU Parameter] ⇒ [Safety Function Setting] ⇒ [Safety Cycle Time]

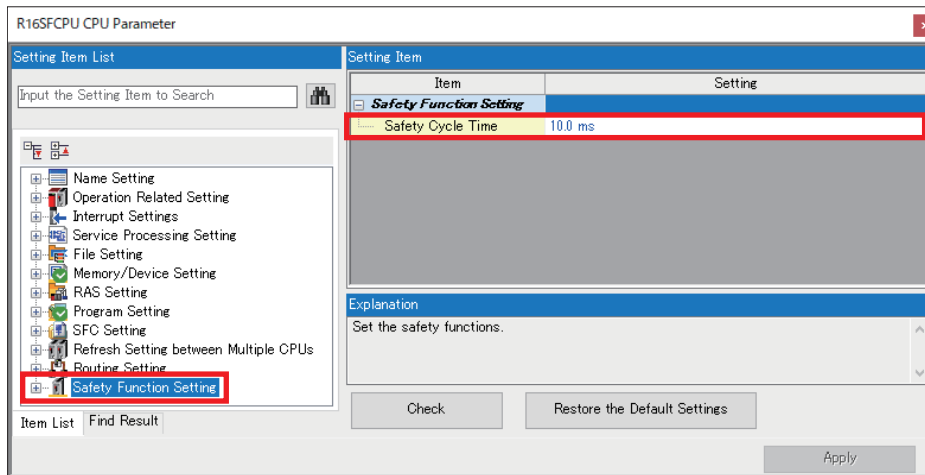

Item	Setting
Safety Cycle Time*1	10.0 ms (default)

\*1 Refer to the following for details of Safety Cycle Time.  
📖 MELSEC iQ-R Programmable Controller CPU Module User's Manual

# Safety communication settings

Set the safety connection and safety device transfer range that are necessary for safety communication.

## Operating procedure

1. Display the module parameters.

Navigation window ⇒ [Parameter] ⇒ [Module Information] ⇒ [RD78G4] ⇒ Double-click [Module Parameter (Network)] ⇒ [Module Parameter] window ⇒ [Basic Settings] ⇒ [Safety Communication Setting]

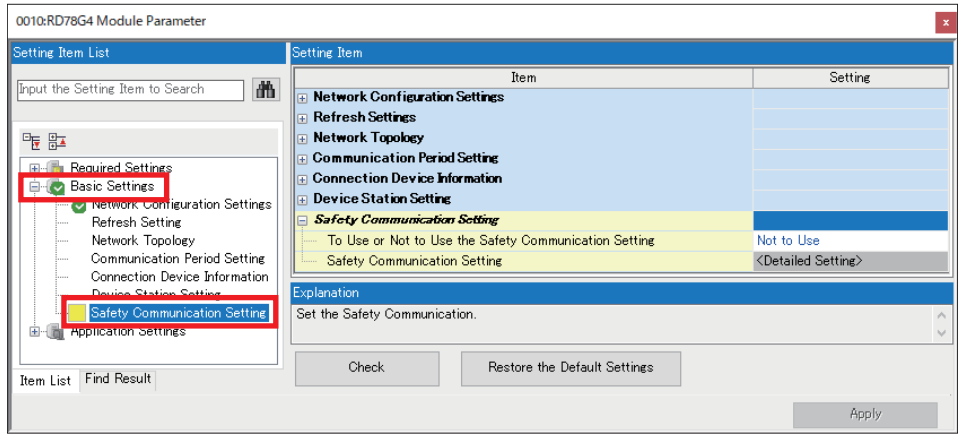

2. Select [Use] for [To Use or Not to Use the Safety Communication Setting], then double-click [<Detailed Setting>]

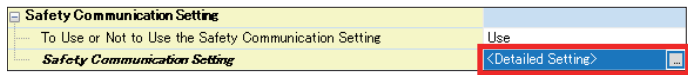

3. A confirmation window appears. Click [OK].

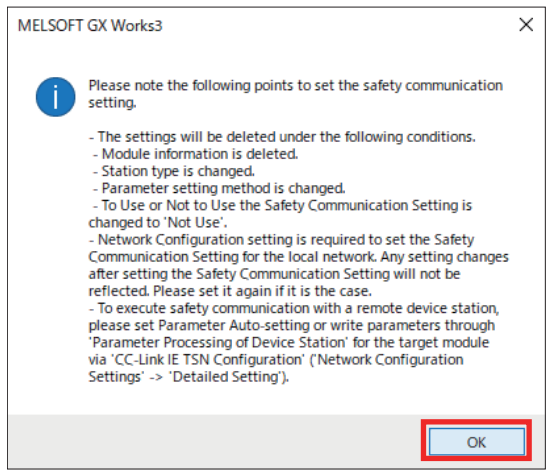

4. The [Safety Communication Setting] window appears. Set the No. 1 communication destination to [Local Network].

No.	Communication Destination	Network No.	Station No.	IP Address	Station Type	Model
1	Local Network					
2						
3						
4						

5. The devices which were set in the network configuration settings are displayed in the candidate fields. Check the checkbox of the device to use for safety communication and click [Add]. Here, check the checkboxes of all the remote stations.

Station No.	IP Address	Station Type	Number of Connections	Model Name
<input checked="" type="checkbox"/>	1 192.168.3.1	Remote Station	1	MR-J5-G-RJ
<input checked="" type="checkbox"/>	2 192.168.3.2	Remote Station	1	NZ2GNSS2-16DTE

6. Configure the [Safety Communication Setting] window as shown below.

No.	Communication Destination	Network No.	Station No.	IP Address	Station Type	Model Name	Communication Destination	PLC No.	Open System	Sending Interval Monitoring Time [ms]	Safety Refresh Monitoring Time [ms]	Receive Data Storage Device (Device Name   Points)	Send Data Storage Device (Device Name   Points)	Safety Authentication Code
1	Local Network	1	1	192.168.3.1	Remote Station	MR-J5-G-RJ			<input checked="" type="checkbox"/>	35.0	60.0	SA#X   92 000000 00001F SA#Y	SA#X   16 000040 00004F	FFFFFFFF
2	Local Network	1	2	192.168.3.2	Remote Station	NZ2GNSS2-16DTE			<input checked="" type="checkbox"/>	35.0	60.0	SA#X   16 000040 00004F SA#Y	SA#Y   16 000040 00004F	FFFFFFFF

Item	Setting	
	No.1	No.2
Sending Interval Monitoring Time [ms] <sup>*1</sup>	35.0	35.0
Safety Refresh Monitoring Time [ms] <sup>*1</sup>	60.0	60.0
Receive Data Storage Device	Device Name	SA#X
	Start	000000
	End	00001F
Send Data Storage Device	Device Name	SA#Y
	Start	000000
	End	00001F

\*1 For [Sending Interval Monitoring Time] and [Safety Refresh Monitoring Time], refer to “Page 46 Monitoring time for safety communication.”

## 7. Click [Check].

Safety Communication Setting

Cyclic Transmission Time(Minimum value) 25.00 MS      Communication Period Interval(Minimum value) 125.00 MS      Setting Method Start/End

No.	Communication Destination	Network Configuration			Configured Module			Open System	Sending Interval Monitoring Time (ms)	Safety Refresh Monitoring Time (ms)	Safety Data Transfer Device Setting						Safety Authentication Code				
		Network No.	Station No.	IP Address	Station Type	Model Name	Communication Destination				PLC No.	Receive Data Storage Device	Send Data Storage Device	Device Name	Points	Start		End	Device Name	Points	Start
1	Local Network	1	1	192.168.3.1	Remote Station	MR-J5-G-RJ		Active	35.0	60.0	Destination Station->	SAWX	32	000000	00001F	SAFY	32	000000	00001F	->Destination Station	FFFFFFFF
2	Local Network	1	2	192.168.3.2	Remote Station	NZ2GNSS2-1NOTE		Active	35.0	60.0	Destination Station->	SAWX	16	000040	00004F	SAFY	16	000040	00004F	->Destination Station	FFFFFFFF
3											Destination Station->									->Destination Station	
4											Destination Station->									->Destination Station	
5											Destination Station->									->Destination Station	
6											Destination Station->									->Destination Station	
7											Destination Station->									->Destination Station	
8											Destination Station->									->Destination Station	
9											Destination Station->									->Destination Station	
10											Destination Station->									->Destination Station	

Buttons: Check, Restore the Default Settings, Output to File (for Setting Confirmation), OK, Cancel

## 8. Click [OK].

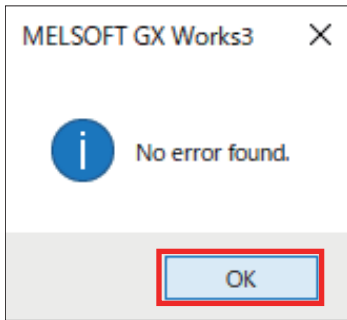

## 9. Click [OK].

Safety Communication Setting

Cyclic Transmission Time(Minimum value) 25.00 MS      Communication Period Interval(Minimum value) 125.00 MS      Setting Method Start/End

No.	Communication Destination	Network Configuration			Configured Module			Open System	Sending Interval Monitoring Time (ms)	Safety Refresh Monitoring Time (ms)	Safety Data Transfer Device Setting						Safety Authentication Code				
		Network No.	Station No.	IP Address	Station Type	Model Name	Communication Destination				PLC No.	Receive Data Storage Device	Send Data Storage Device	Device Name	Points	Start		End	Device Name	Points	Start
1	Local Network	1	1	192.168.3.1	Remote Station	MR-J5-G-RJ		Active	35.0	60.0	Destination Station->	SAWX	32	000000	00001F	SAFY	32	000000	00001F	->Destination Station	FFFFFFFF
2	Local Network	1	2	192.168.3.2	Remote Station	NZ2GNSS2-1NOTE		Active	35.0	60.0	Destination Station->	SAWX	16	000040	00004F	SAFY	16	000040	00004F	->Destination Station	FFFFFFFF
3											Destination Station->									->Destination Station	
4											Destination Station->									->Destination Station	
5											Destination Station->									->Destination Station	
6											Destination Station->									->Destination Station	
7											Destination Station->									->Destination Station	
8											Destination Station->									->Destination Station	
9											Destination Station->									->Destination Station	
10											Destination Station->									->Destination Station	

Buttons: Check, Restore the Default Settings, Output to File (for Setting Confirmation), OK, Cancel

## 10. Click [Check].

0010:RD78G4 Module Parameter

Setting Item List

Input the Setting Item to Search

- Required Settings
- Basic Settings
  - Network Configuration Settings
  - Refresh Setting
  - Network Topology
  - Communication Period Setting
  - Connection Device Information
  - Device Station Setting
  - Safety Communication Setting
- Application Settings

Setting Item

Item	Setting
Network Configuration Settings	
Refresh Settings	
Network Topology	
Communication Period Setting	
Connection Device Information	
Device Station Setting	
Safety Communication Setting	
To Use or Not to Use the Safety Communication Setting	Use
Safety Communication Setting	<Detailed Setting>

Explanation

Set the connection to execute safety communication and the transfer range of safety device.

Buttons: Check, Restore the Default Settings, Apply

11. Click [OK].

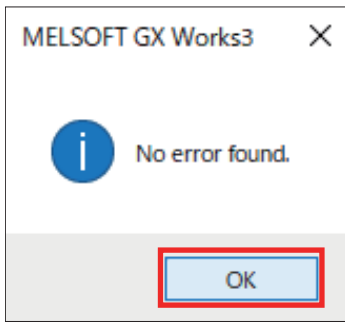

12. Click [Apply]. Check that  disappears.

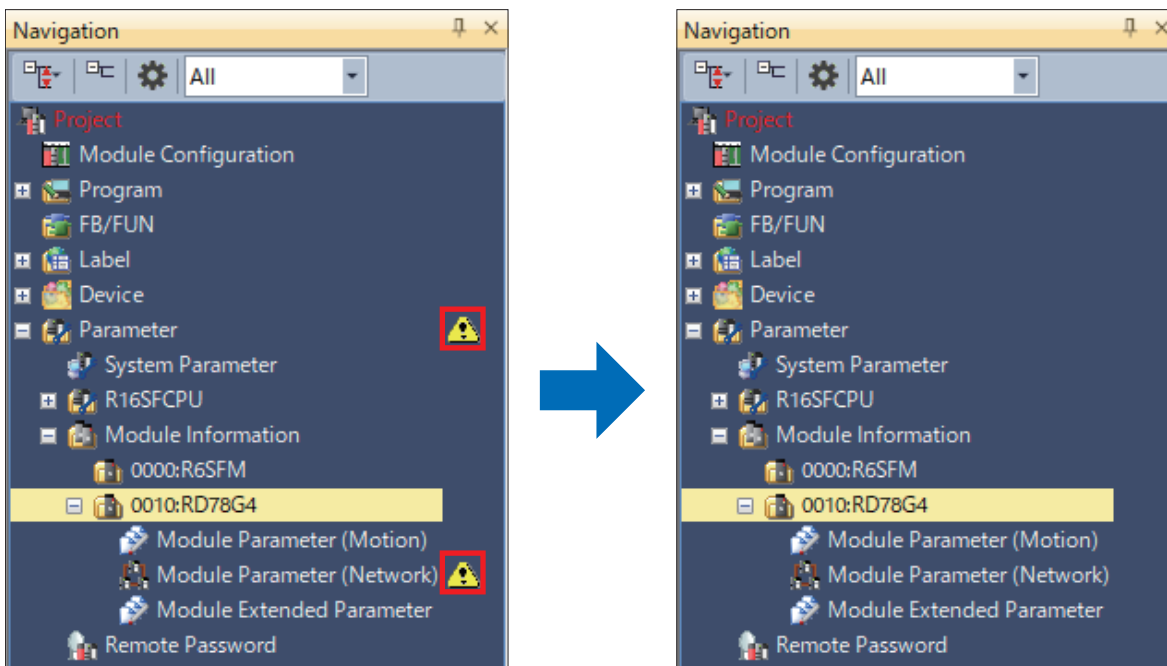

## Precautions

The safety communication settings are deleted under the following conditions.

- Module information delete
- Station type change
- Parameter setting method change
- [To Use or Not to Use the Safety Communication Setting] is changed to [Not to Use].

## Safety data transfer device setting

There is no setting on the servo amplifier side for selecting the device, such as selecting a B device or Y device. STO and other bits are allocated to the selected device.

The set safety data transfer device is assigned to the following servo amplifier signals.

- Master station → Servo amplifier

Servo amplifier input signals			Master station safety device
Bit	Input command	Description	
0	STO command	When the STO command is OFF, the servo amplifier STO function activates and the supply of energy is shut off.	SA#Y0
1	SS1 command	When the SS1 command is OFF, the SS1 function activates.	SA#Y1
2	SS2 command	When the SS2 command is OFF, the SS2 function activates.	SA#Y2
3 to 4	Cannot be used		SA#Y3 to SA#Y4
5	SDIP command	When the SDIP command is OFF, the SDIP function activates.	SA#Y5
6	SDIN command	When the SDIN command is OFF, the SDIN function activates.	SA#Y6
7	Cannot be used		SA#Y7
8	SLS1 command	When the SLS1 command is OFF, the SLS1 function activates.	SA#Y8
9	SLS2 command	When the SLS2 command is OFF, the SLS2 function activates.	SA#Y9
10	SLS3 command	When the SLS3 command is OFF, the SLS3 function activates.	SA#YA
11	SLS4 command	When the SLS4 command is OFF, the SLS4 function activates.	SA#YB
12 to 13	Cannot be used		SA#YC to SA#YD
14	SLI command	When the SLI command is OFF, the SLI function activates.	SA#YE
15 to 23	Cannot be used		SA#YF to SA#Y17
24	SLT1 command	When the SLT1 command is OFF, the SLT1 function activates.	SA#Y18
25	SLT2 command	When the SLT2 command is OFF, the SLT2 function activates.	SA#Y19
26	SLT3 command	When the SLT3 command is OFF, the SLT3 function activates.	SA#Y1A
27	SLT4 command	When the SLT4 command is OFF, the SLT4 function activates.	SA#Y1B
28 to 31	Cannot be used		SA#Y1C to SA#Y1F

• Servo amplifier → Master station

Servo amplifier output signals			Master station safety device
Bit	Function output	Description	
0	STO output	Turns ON when the STO function activates and the energy supply is shut off.	SA#X0
1	SSM output	Turns ON when the servo motor speed is at or below the set SSM speed.	SA#X1
2	Cannot be used		SA#X2
3	SOS output	Turns ON when the SS2 function activates the SOS function.	SA#X3
4	Cannot be used		SA#X4
5	SDIP output	Turns ON when the SDIP function activates.	SA#X5
6	SDIN output	Turns ON when the SDIN function activates.	SA#X6
7	Safety communication error 1	Turns ON when an error related to safety communication occurs.	SA#X7
8	SLS1 output	Turns ON when the SLS1 function activates.	SA#X8
9	SLS2 output	Turns ON when the SLS2 function activates.	SA#X9
10	SLS3 output	Turns ON when the SLS3 function activates.	SA#XA
11	SLS4 output	Turns ON when the SLS4 function activates.	SA#XB
12	SS1 output	Turns ON when the SS1 function activates.	SA#XC
13	SS2 output	Turns ON when the SS2 function activates.	SA#XD
14	SLI output	Turns ON when the SLI function activates.	SA#XE
15 to 16	Cannot be used		SA#XF to SA#X10
17	Safety communication error 2	Turns ON when a command signal for a safety sub-function that cannot be used is input.	SA#X11
18	SBC output	Turns ON when the STO function activates and the supply of energy to the electromagnetic brake is shut off.	SA#X12
19 to 23	Cannot be used		SA#X13 to SA#X17
24	SLT1 output	Turns ON when the SLT1 function activates.	SA#X18
25	SLT2 output	Turns ON when the SLT2 function activates.	SA#X19
26	SLT3 output	Turns ON when the SLT3 function activates.	SA#X1A
27	SLT4 output	Turns ON when the SLT4 function activates.	SA#X1B
28 to 31	Cannot be used		SA#X1C to SA#X1F

## Monitoring time for safety communication

This section explains the monitoring time for safety communication.

Monitoring times are set for each safety connection. When each time exceeds the monitoring time, safety communication timeout is detected and safety communication stops.

Station where set	Item	Description	Station using the set time
Master station	Transmission interval monitoring time	<ul style="list-style-type: none"> <li>The device station monitors the interval ❶ at which safety data is sent by the master station.</li> <li>The master station sends this to the device station when safety communication starts.</li> <li>Monitoring is performed by comparing the sending time information that is added to the safety data received by the device station with the previous value.</li> </ul>	Device station
	Safety refresh monitoring time*1	<p>The master station monitors the interval ❷ at which safety data is received from the device station.</p> <ul style="list-style-type: none"> <li>The device station monitors the interval ❸ at which safety data is received from the master station.</li> <li>The master station sends this to the device station when safety communication starts.</li> </ul>	Master station
Device station	Transmission interval monitoring time	<ul style="list-style-type: none"> <li>The master station monitors the interval ❹ at which safety data is sent by the device station.</li> <li>The device station sends this to the master station when safety communication starts.</li> <li>Monitoring is performed by comparing the sending time information that is added to the safety data received by the master station with the previous value.</li> </ul>	Master station

\*1 Safety refresh monitoring time uses a common value at the master station and device station.

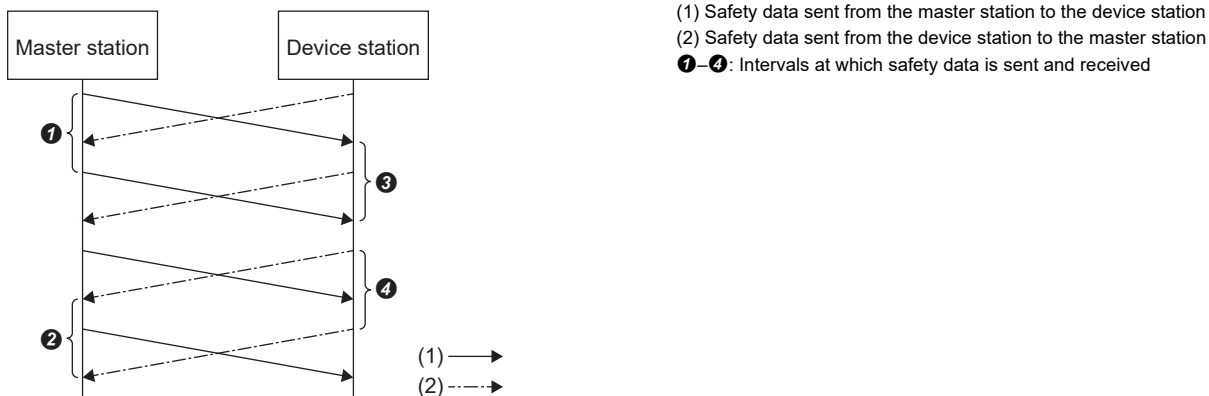

### Transmission interval monitoring time

Refer to below for the method of calculating the transmission interval monitoring time that is set at the master station.

📖 MELSEC iQ-R CC-Link IE TSN User's Manual (Application)

Refer to below for the method of calculating the transmission interval monitoring time that is set at the servo amplifier.

📖 MR-J5 User's Manual (Function)

Refer to below for the method of calculating the transmission interval monitoring time that is set at the safety remote I/O module.

📖 CC-Link IE TSN Remote I/O Module (With Safety Functions) User's Manual

### Safety refresh monitoring time

Safety refresh monitoring time is set at the active-side station.

Refer to below for the method of calculating the safety refresh monitoring time.

📖 MELSEC iQ-R CC-Link IE TSN User's Manual (Application)

## 2.7 Extended Parameter Settings

Configure the settings related to axis operation other than the network settings, and perform label registration for the I/O data that is used in motion control.

Navigation window ⇒ [Parameter] ⇒ [Module Information] ⇒ [RD78G4] ⇒ Double-click [Module Extended Parameter] ⇒ [Motion Control Setting Function] window

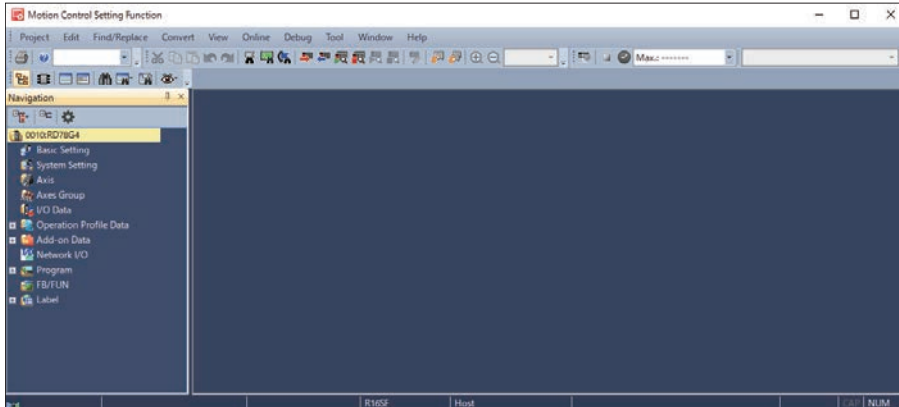

For details of the settings, refer to the following manual.

 Motion Control Setting Function

### Point

If motion control settings are not installed, download and install the motion control software from the Mitsubishi Electric FA Global Website.

### Precautions

The settings introduced in this section are an example. When using with an actual system, give sufficient consideration to ensure that there are no problems with control in that system.

For details of the parameters, refer to the following manuals.

 MELSEC iQ-R Motion Module User's Manual (Application)

 MELSEC iQ-R Motion Module User's Manual (Network)

 MR-J5-G/MR-J5W-G User's Manual (Parameters)

# Servo Amplifier

Set the MR-J5-G-RJ parameters.

## Operating procedure

### 1. Create a new axis setting.

Navigation window ⇒ Right-click on [Axis]. ⇒ [New Data]

Basic Setting	
Data Type	Axis
(Data Name)	Axis0001

Detailed Setting	
Axis Information	
Axis No.	1
Axis Parameter Constant	
Station Address Setting	...
Axis Type Setting	Real Drive Axis
Control Cycle Setting	Operate in the First Operation Cycle

### 2. Click [...] for Station Address Setting.

Basic Setting	
Data Type	Axis
(Data Name)	Axis0001

Detailed Setting	
Axis Information	
Axis No.	1
Axis Parameter Constant	
Station Address Setting	...
Axis Type Setting	Real Drive Axis
Control Cycle Setting	Operate in the First Operation Cycle

3. Select [192.168.3.1] and click [OK].

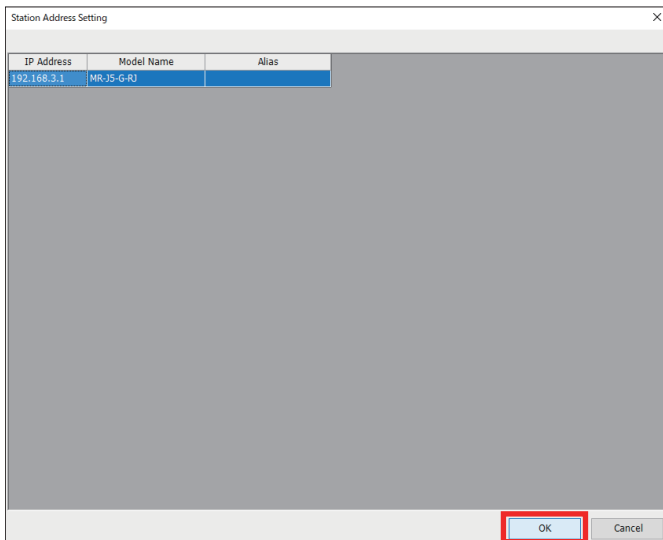

The image shows a dialog box titled "Station Address Setting". It contains a table with three columns: "IP Address", "Model Name", and "Alias". The first row of the table has the values "192.168.3.1", "MR-J5-G-RJ", and an empty cell. The "OK" button at the bottom right is highlighted with a red box.

IP Address	Model Name	Alias
192.168.3.1	MR-J5-G-RJ	

4. Check the contents of the Axis No. and Station Address, then click [OK].

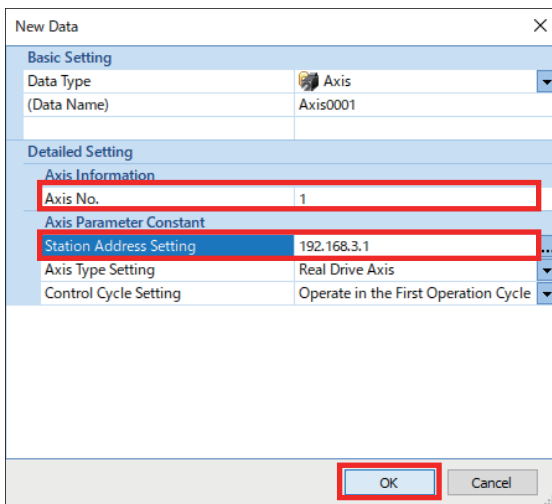

The image shows a dialog box titled "New Data". It has two main sections: "Basic Setting" and "Detailed Setting". In the "Basic Setting" section, "Data Type" is set to "Axis" and "(Data Name)" is "Axis0001". In the "Detailed Setting" section, "Axis No." is set to "1" and "Station Address Setting" is set to "192.168.3.1". The "OK" button at the bottom right is highlighted with a red box.

Basic Setting	
Data Type	Axis
(Data Name)	Axis0001
Detailed Setting	
Axis Information	
Axis No.	1
Axis Parameter Constant	
Station Address Setting	192.168.3.1
Axis Type Setting	Real Drive Axis
Control Cycle Setting	Operate in the First Operation Cycle

Item	Setting
Axis No.	1
Station Address Setting	192.168.3.1

## 5. Set the Electronic Gear.

[Real Drive Axis] ⇒ [Axis Parameters] ⇒ [Driver Unit Conversion Numerator] ⇒ [...]

Electronic Gear Setting Axis0001

**Entry**

Select the machine components, and enter the machine data to automatically set the axis parameters (position command unit, driver unit conversion numerator and driver unit conversion denominator).

Machine Components : Rotary Table

Position Command Unit : Revolution

One Revolution : 1.0000 [Revolution]

Reduction Ratio (NL/NM) = 1 / 1

Calculate reduction ratio by teeth or diameters Reduction Ratio Setting

Encoder Resolution : 67108864 [pulse/rev]

Setting Range : 1[pulse/rev] to 2147483647[pulse/rev]

Calculate Axis Parameters

**Calculation Result**

Axis Parameters	Value
Position Command Unit	Revolution
Driver Unit Conversion Numerator	
Driver Unit Conversion Denominator	

Movement Amount per Driver Unit Command

\* The electronic gear on driver side is calculated as 1:1.

As a result of calculation, no error occurs in the movement amount.

Applying the calculation result above,

the error for every 0.0 [mm] (movement amount) you perform is about: 0.0 [mm]

OK Cancel

Item	Setting
Machine Components	Rotary Table
Position Command Unit	Revolution
Encoder Resolution	67108864

## 6. Click [Calculate Axis Parameters] to calculate the Electronic Gear numerator and denominator. Click [OK].

Electronic Gear Setting Axis0001

**Entry**

Select the machine components, and enter the machine data to automatically set the axis parameters (position command unit, driver unit conversion numerator and driver unit conversion denominator).

Machine Components : Rotary Table

Position Command Unit : Revolution

One Revolution : 1.0000 [Revolution]

Reduction Ratio (NL/NM) = 1 / 1

Calculate reduction ratio by teeth or diameters Reduction Ratio Setting

Encoder Resolution : 67108864 [pulse/rev]

Setting Range : 1[pulse/rev] to 2147483647[pulse/rev]

Calculate Axis Parameters

**Calculation Result**

Axis Parameters	Value
Position Command Unit	Revolution
Driver Unit Conversion Numerator	67108864
Driver Unit Conversion Denominator	1

Movement Amount per Driver Unit Command

\* The electronic gear on driver side is calculated as 1:1.

As a result of calculation, no error occurs in the movement amount.

Applying the calculation result above,

the error for every 0.0 [Revolution] (movement amount) you perform is about: 0.0 [Revolution]

Click OK to reflect to the axis parameters.

OK Cancel

7. Click [Yes].

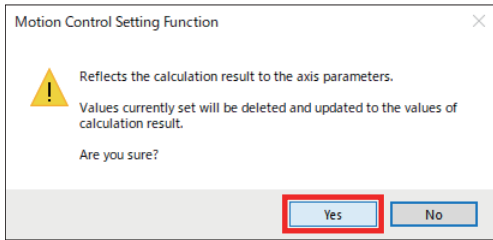

8. In this manual, because home position return is not used, it is set as shown below.

[Real Drive Axis] ⇒ [Axis Parameter] ⇒ [Homing Required or Not]

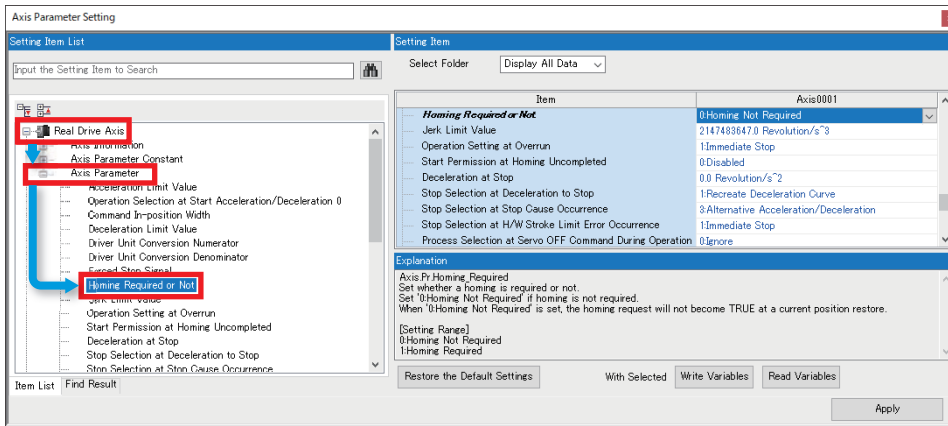

Item	Setting
Homing Required or Not	0: Homing Not Required

9. Set the following contents for [Position Command Unit] and [Velocity Command Unit], then click [Apply].

 [Real Drive Axis] ⇒ [Axis Parameter] ⇒ [Position Command Unit] and [Velocity Command Unit]

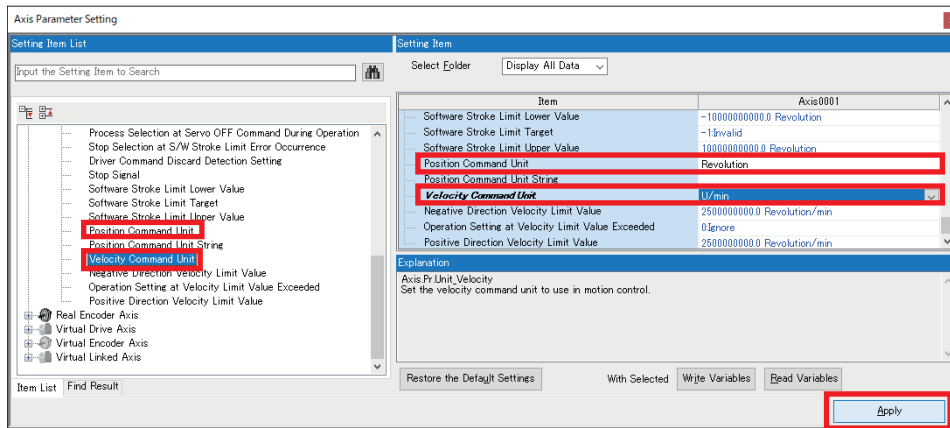

Item	Setting
Position Command Unit	Revolution
Velocity Command Unit	U/min

# Safety remote I/O module

Set the parameters for the safety remote I/O module.

## Operating procedure

### 1. Set network I/O.

Navigation window ⇒ Double-click [Network I/O] ⇒ [Network I/O] window

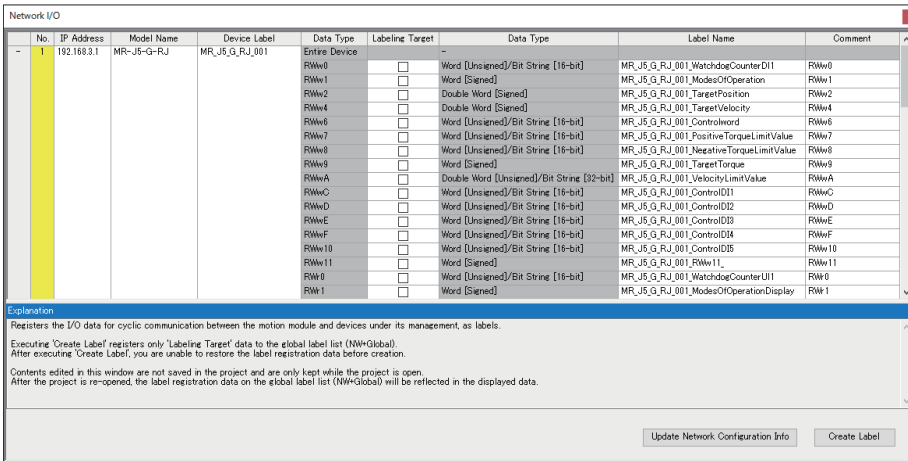

### 2. Check the checkboxes of RX2 to RX5 for NZ2GNSS2-16DTE, then click [Create Label].

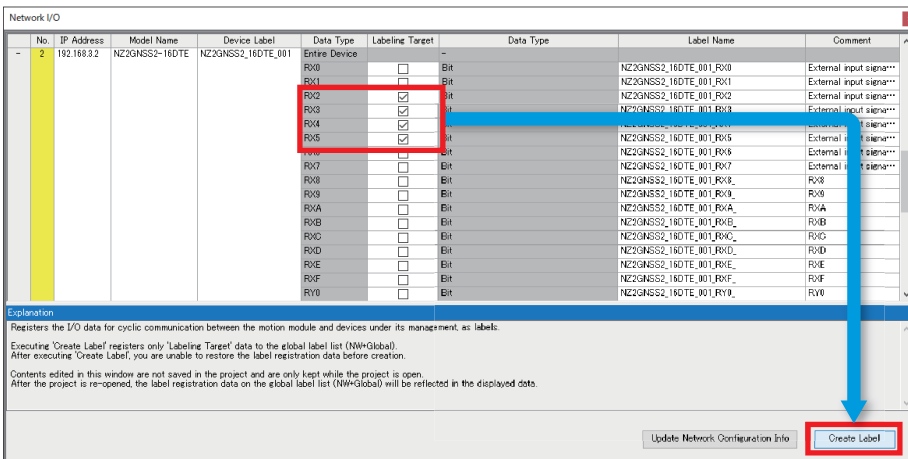

### 3. In the confirmation window, click [Yes].

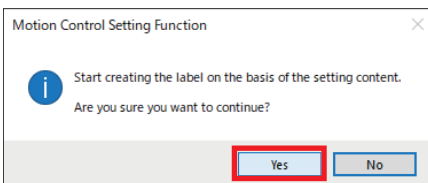

4. Set [Public Label] to [Enabled] in order to use the registered global labels in the sequence program.

Navigation window ⇒ [Label] ⇒ [Global Label] ⇒ Double-click [NW+Global1]

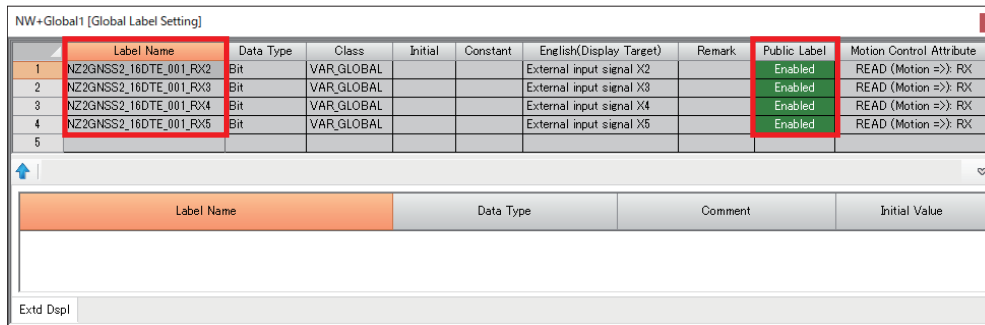

No.	Label Name	Public Label
1	NZ2GNSS2_16DTE_001_RX2	Enabled
2	NZ2GNSS2_16DTE_001_RX3	Enabled
3	NZ2GNSS2_16DTE_001_RX4	Enabled
4	NZ2GNSS2_16DTE_001_RX5	Enabled

5. Perform conversion.

[Convert] ⇒ [Rebuild All]

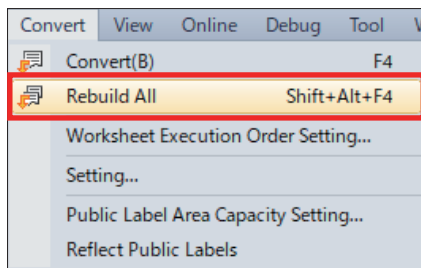

6. Click [OK].

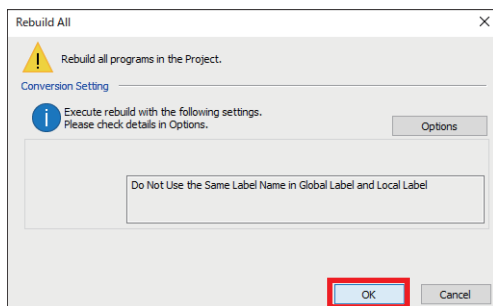

7. The generated public label information is applied to the project on the CPU module side.

 [Convert] ⇒ [Reflect Public Labels]

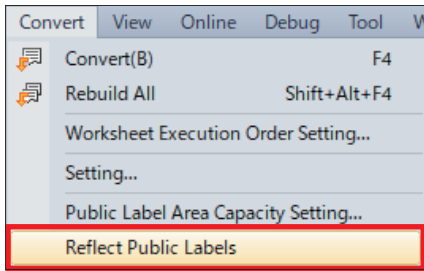

8. Click [Yes].

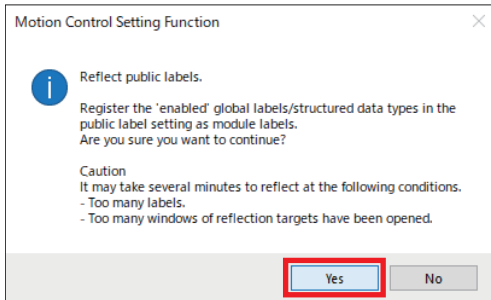

9. Click [OK].

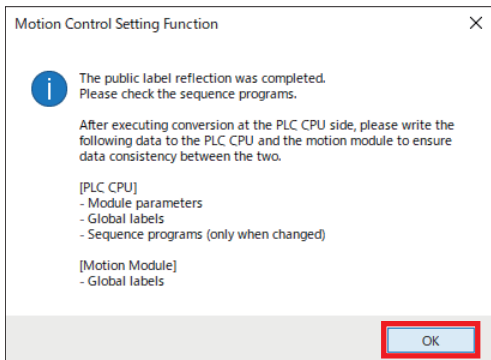

10. Perform [Rebuild All] with GX Works3.

 [Convert] ⇒ [Rebuild All]

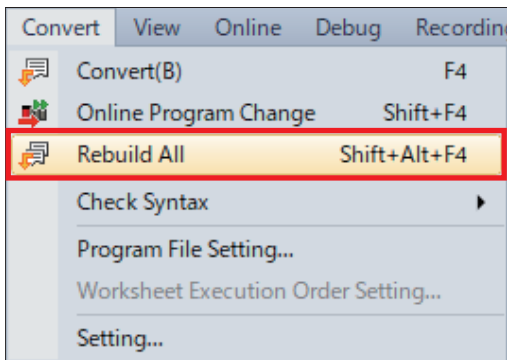

11. Check that Label Assignment is [Reassignment], then click [OK].

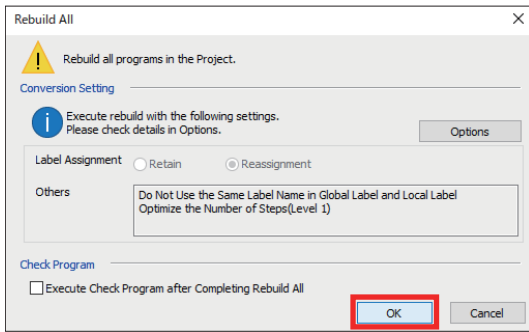

If Label Assignment is [Retain], click [Options] and select [Yes] for [Reassign Labels in Executing Rebuild All].

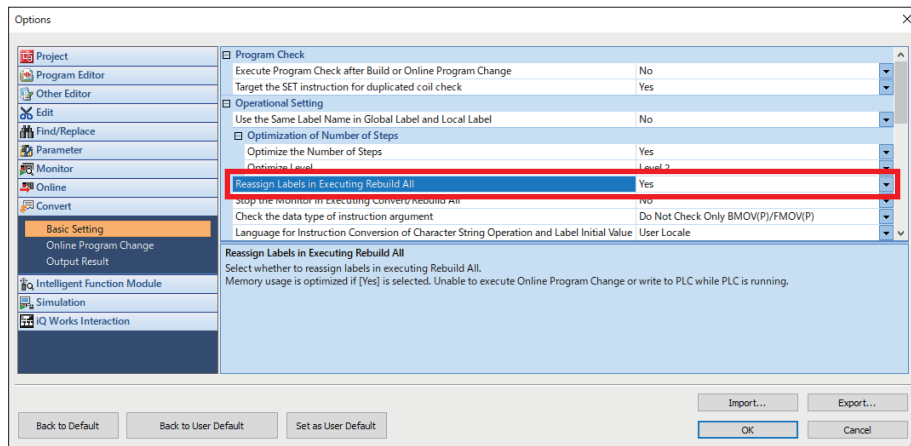

# Writing extended parameters

Write the contents which were set in the [Motion Control Setting Function] window to the RD78G4.

## Operating procedure

1. Perform the following operations on the [Motion Control Setting Function] window.

 [Online] ⇒ [Write to PLC] ⇒ [Online Data Operation] window

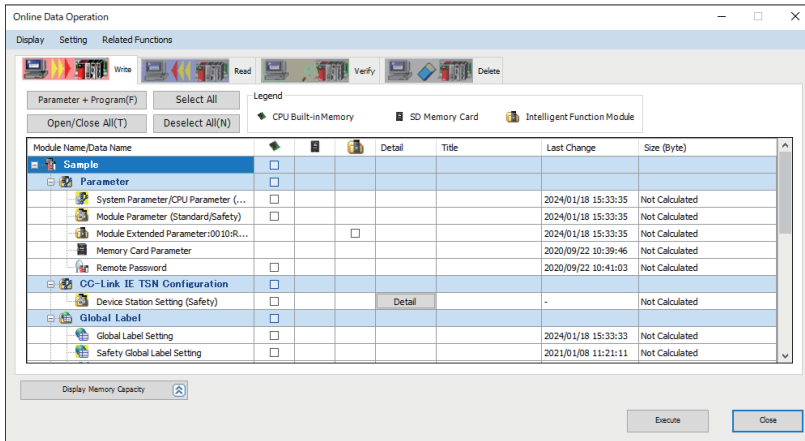

2. Select the file to write and click [Execute]. Here, click [Select All].

 [Select All] ⇒ [Execute]

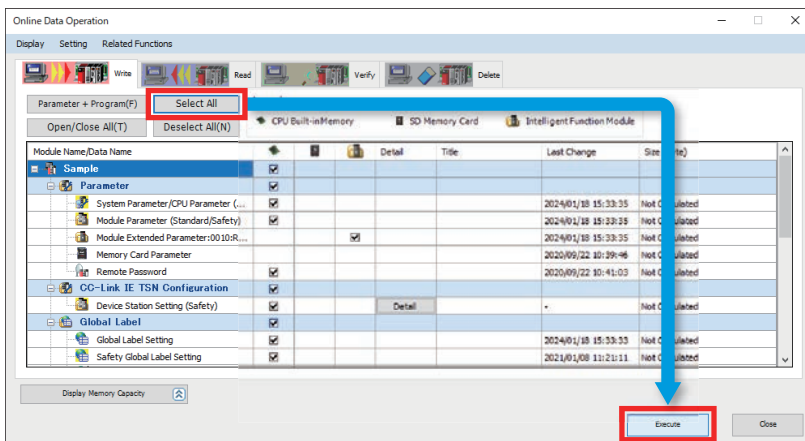

3. After writing is completed, click [Close].

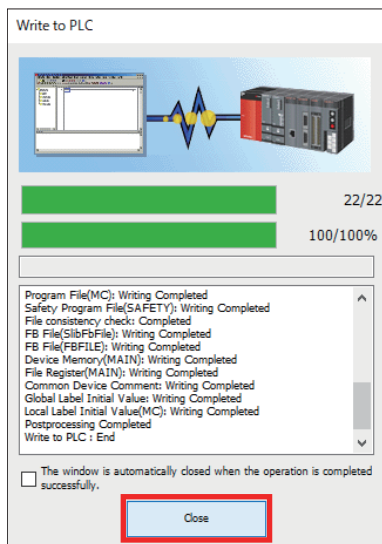

4. Click [Close].

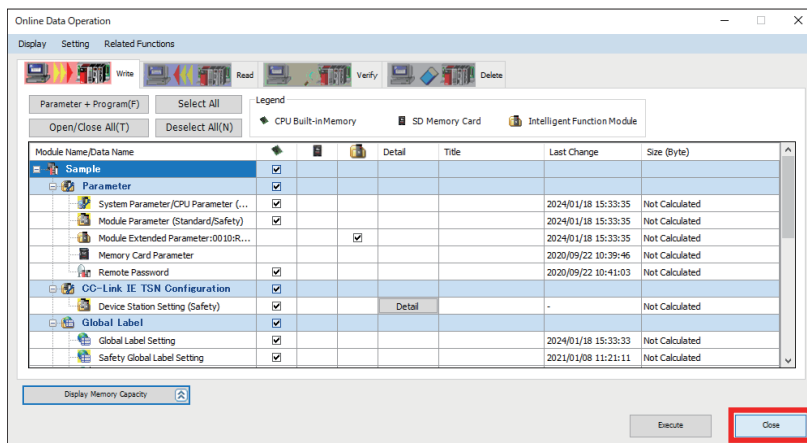

## 2.8 Safety Function Cancel Program

When performing safety sub-function control using a network, it is necessary to create a program that cancels the safety functions in advance.

The safety function can be canceled by turning the corresponding assigned bit ON.

Bit assignments are the contents set in “ Page 39 Safety Communication Settings.”

Create an operation program such as the following.

For program details, refer to “ Page 95 Sample Program.”

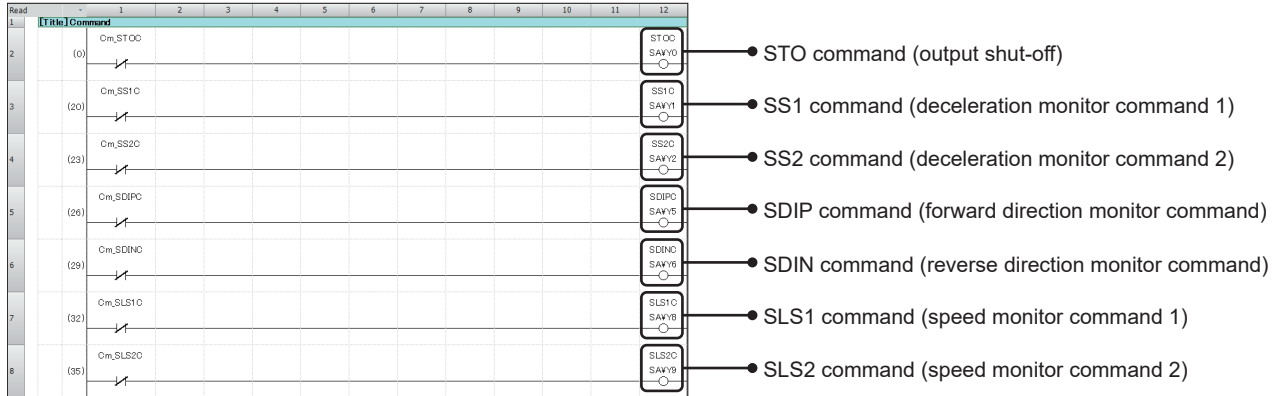

**Point**

In this program, the safety functions are enabled/disabled by turning the assigned label device ON/OFF.

### Canceling the safety functions

The conditions when each safety function has been canceled are shown below.

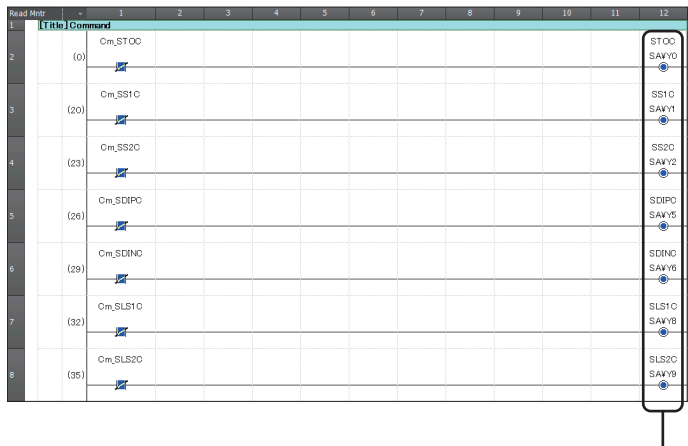

Because each bit is ON, the safety functions are not activated.

## Enabling safety functions

The conditions when the safety functions are enabled are shown below.

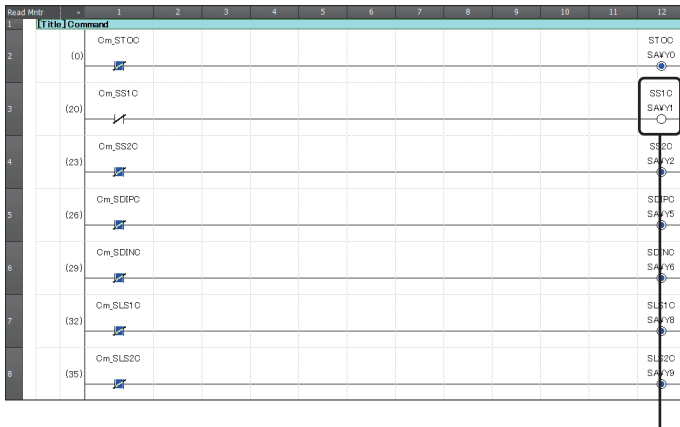

When Cm\_SS1C is turned ON, SA¥Y1 turns OFF and the SS1 function is activated.

## 2.9 Program Writing

Write the settings that have been made using GX Works3 so far to the CPU module.

### Point

- Stop the CPU module.
- Connect the CPU module and PC using the USB cable.
- Set the GX Works3 connection destination setting to USB.

### Operating procedure

1. Perform [Rebuild All].

[Convert] ⇄ [Rebuild All]

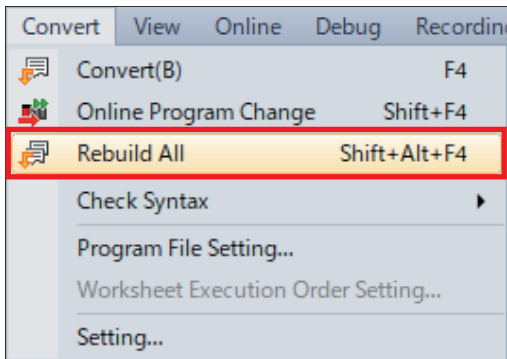

2. Check that Label Assignment is [Reassignment], then click [OK].

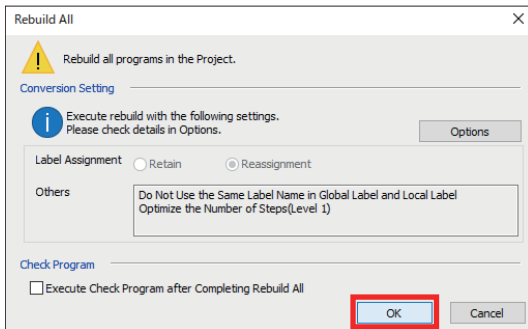

Point

If Label Assignment is [Retain], click [Options] and select [Yes] for [Reassign Labels in Executing Rebuild All].

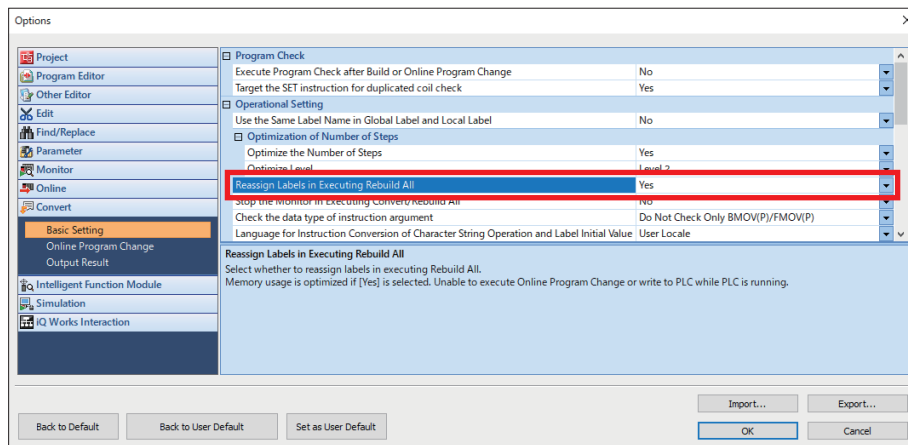

3. Display the [Online Data Operation] window.

🖱️ [Online] ⇒ [Write to PLC] ⇒ [Online Data Operation] window

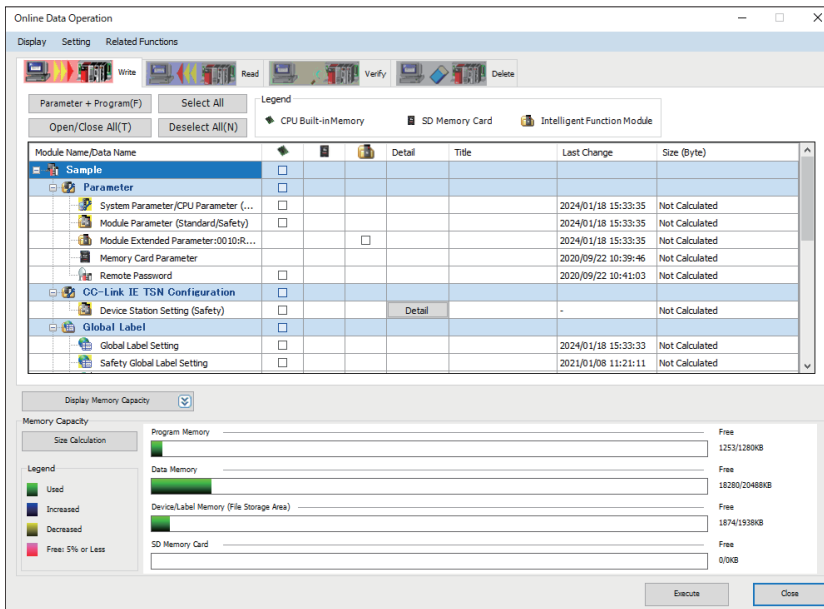

#### 4. Execute writing to the programmable controller.

 [Select All] ⇒ [Execute]

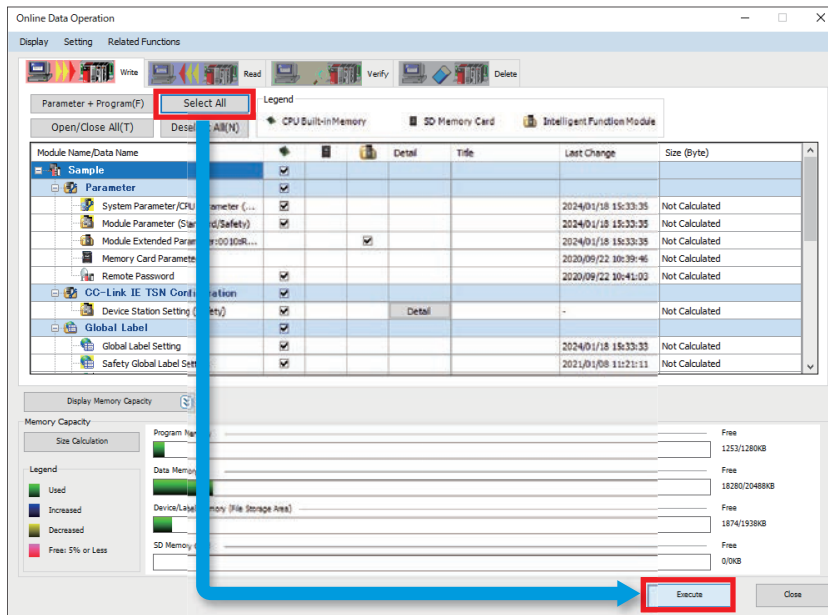

#### Point

If a user authentication message is displayed, follow the instructions on the screen.

#### 5. When writing to the programmable controller is completed, click [Close].

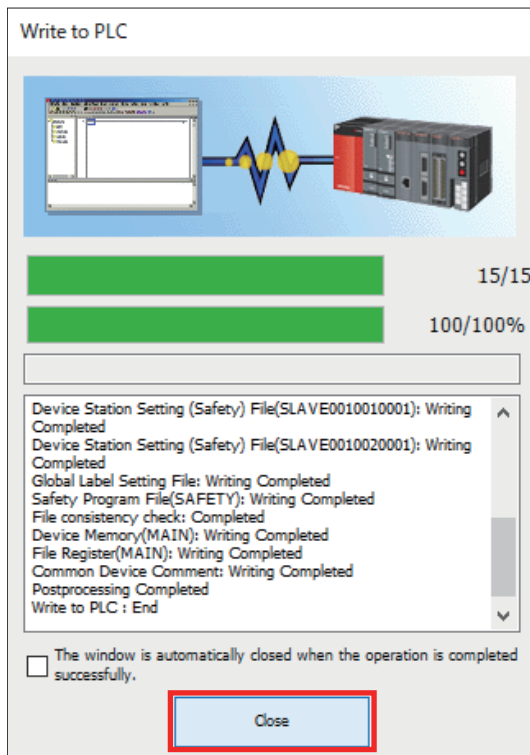

6. A writing completed window appears. Check the checkboxes of [Confirmation 1] and [Confirmation 2], then click [Close].

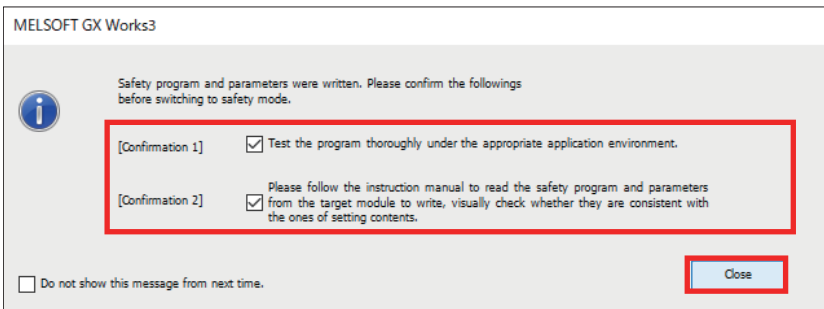

2

7. Each time that writing to the safety programmable controller is performed, the e-Manual Viewer launches and an explanation about switching safety operation mode is displayed. Select whether to operate normally as a safety system (SAFETY MODE) or whether to change the safety program, safety parameters, or other elements (TEST MODE). This function was installed based on instructions from the certification agency. Here you can leave it in TEST MODE. Close the e-Manual Viewer window.

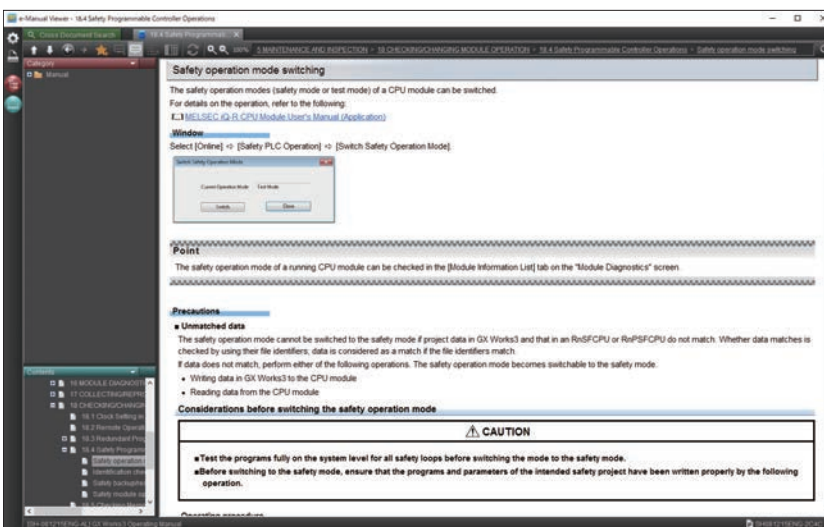

8. Click [Close].

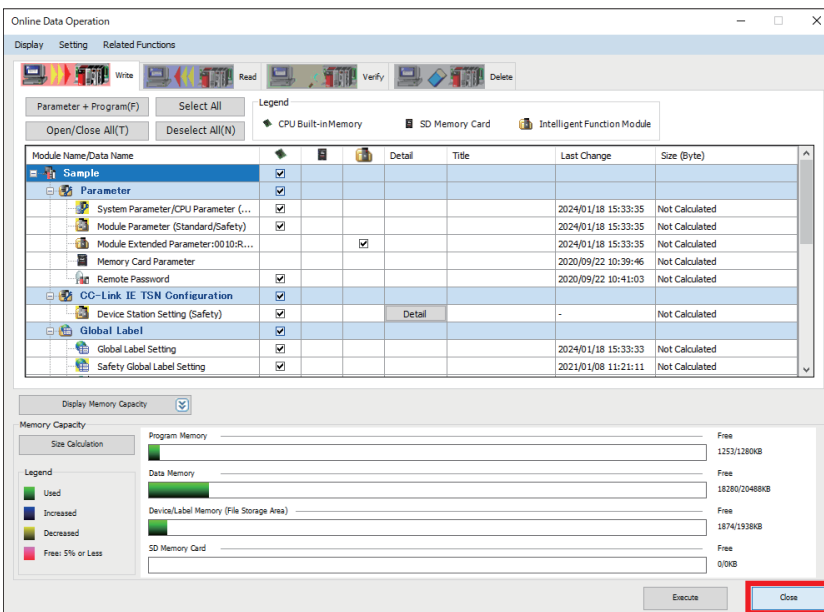

After writing is completed, turn the power to the overall system OFF and back ON.

# 2.10 Safety Parameter Settings Using MR Configurator2

## Setting the servo amplifier safety parameters

Use MR Configurator2 and set the servo amplifier safety parameters.

Here, set the following items. The setting contents are explained beginning from step 7.

### Precautions

The settings introduced in this section are an example. When using with an actual system, give sufficient consideration to ensure that there are no problems with control in that system.

For details of the parameters, refer to the following manuals.

MELSEC iQ-R Motion Module User's Manual (Application)

MELSEC iQ-R Motion Module User's Manual (Network)

MR-J5-G/MR-J5W-G User's Manual (Parameters)

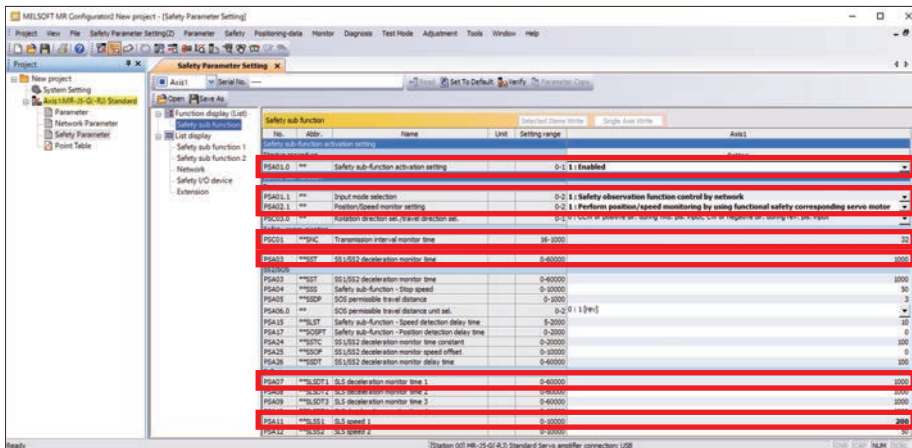

Parameter No.	Name
PSA01.0	Safety sub-function activation setting
PSA01.1	Input mode selection
PSA02.1	Position/Speed monitor setting
PSC01	Transmission interval monitor time
PSA03	SS1/SS2 deceleration monitor time
PSA07	SLS deceleration monitor time 1
PSA11	SLS speed 1

## Operating procedure

1. Connect the servo amplifier and PC by USB.
2. Start MR Configurator2.
3. Create a project.  
↔ [Project] ⇒ [New Project]
4. If a project close confirmation window appears, click [Yes].

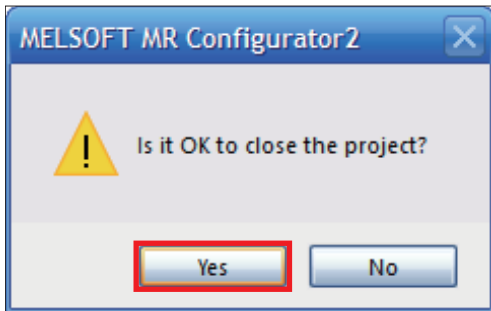

5. In the [New Project] window, set the model of the servo amplifier and click [OK].

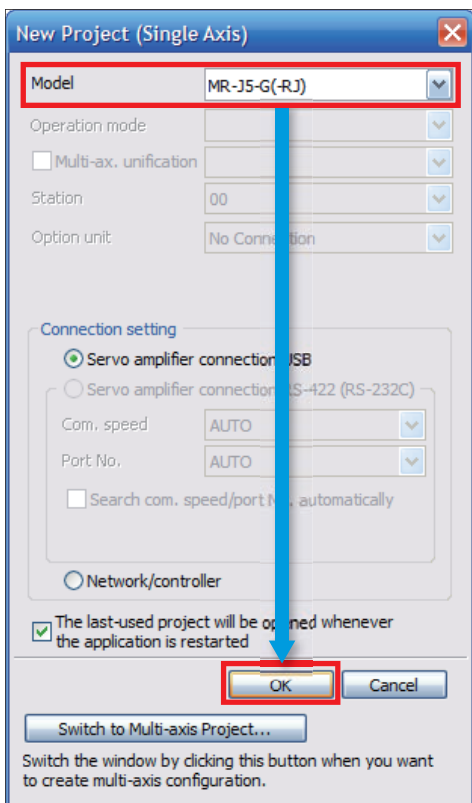

Item	Setting
Model	MR-J5-G(-RJ)

6. A window confirming reading of parameters from the servo amplifier appears. Click [No].

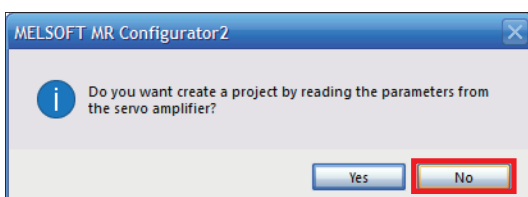

## 7. Enable [Safety sub-function].

[Safety] ⇒ [Safety Parameter Setting] ⇒ [Function display (List)] ⇒ [Safety sub-function]

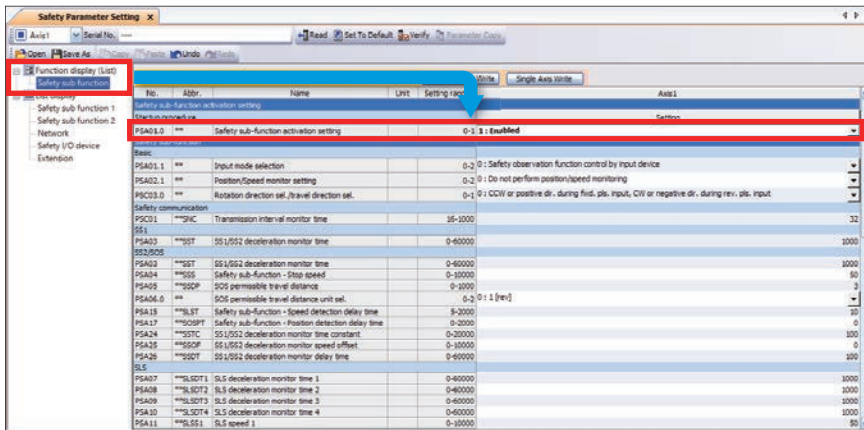

Item	Setting
Safety sub-function activation setting	1: Enabled

## 8. Configure the settings related to the safety sub-function.

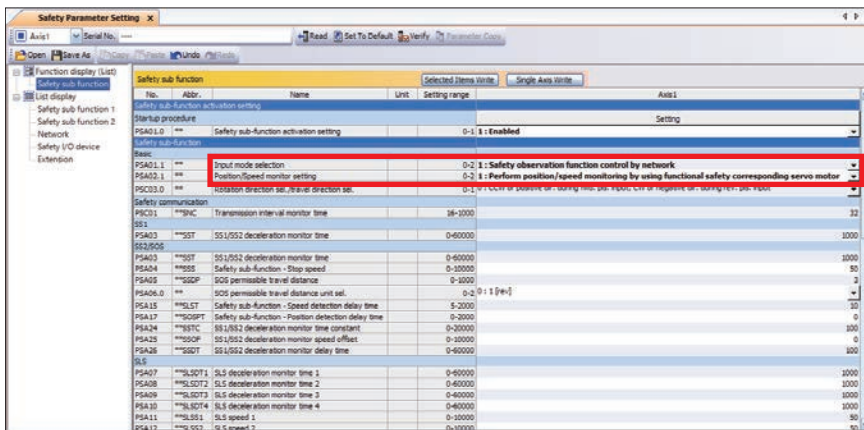

Item	Setting
Input mode selection	1: Safety observation function control by network
Position/Speed monitor setting	1: Perform position/speed monitoring by using functional safety corresponding servo motor

### Point

In the safety sub-function settings, the recommended parameter settings and achievable safety level vary depending on the system configuration.

## 9. Set the transmission interval monitor time.

For information about the transmission interval monitor time, refer to “ Page 46 Monitoring time for safety communication.”

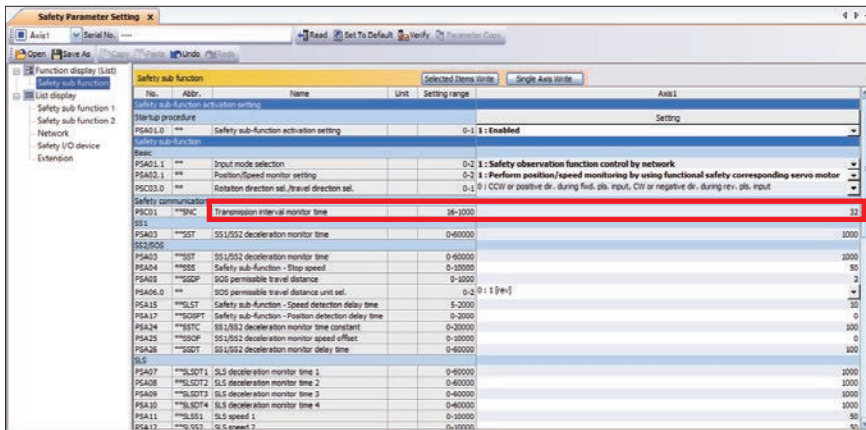

Item	Setting
Transmission interval monitor time	32 (default)

## 10. In this manual, because the SS1 function is used, set the deceleration monitor time for the SS1 function.

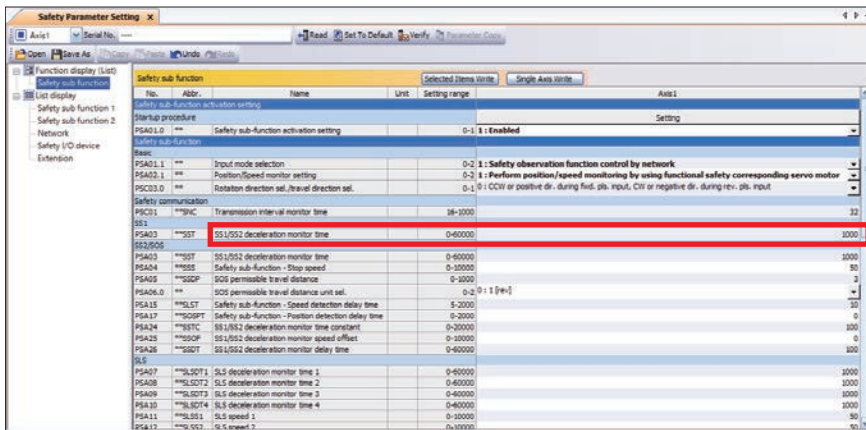

Item	Setting
SS1/SS2 deceleration monitor time	1000 (default)

### Point

Because the SS1 function is used when an error was found as a result of self-diagnosis, be sure to set the SS1 function parameters.

11. In this manual, because the SLS function is used, configure the settings for the SLS function.

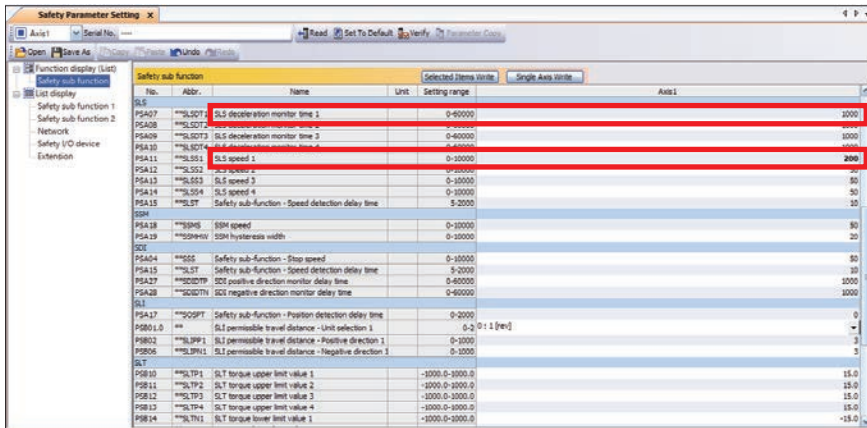

Item	Setting
SLS deceleration monitor time 1	1000 (default)
SLS speed 1	200

# Writing the safety parameter settings

Write the parameters that have been set using MR Configurator2 so far to the servo amplifier.

There are two writing methods: [Single Axis Write] and [Selected Items Write].

- Single Axis Write: All parameters are written for the selected axis.
- Selected Items Write: Parameters are written only for the selected items.

Here we explain the procedure for [Selected Items Write].

## Operating procedure

Repeatedly execute steps 1 to 5 and write the next parameters to the servo amplifier. However perform writing of the safety sub-function activation setting last.

Parameter No.	Name
PSA01.0	Safety sub-function activation setting
PSA01.1	Input mode selection
PSA02.1	Position/Speed monitor setting
PSC01	Transmission interval monitor time
PSA03	SS1/SS2 deceleration monitor time
PSA07	SLS deceleration monitor time 1
PSA11	SLS speed 1

### 1. Select the parameter to write.

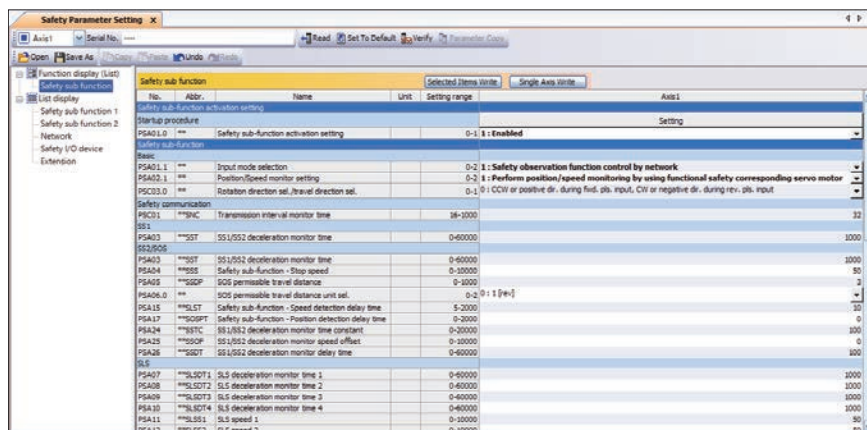

### 2. Click [Selected Items Write].

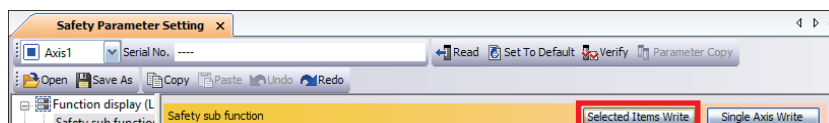

### 3. A confirmation window appears. Click [Yes]. (The window below is an example.)

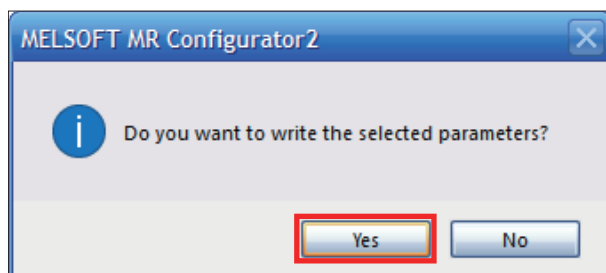

4. A password authentication window appears. Enter the password and click [OK].



**Point** 

---

The password "000000" is set on the hardware side (MR-J5-10G-RJ) at the time of factory shipment. The password authentication window appears at first start, or when password authentication has not yet been completed.

---

5. A write completion window appears. Click [OK].

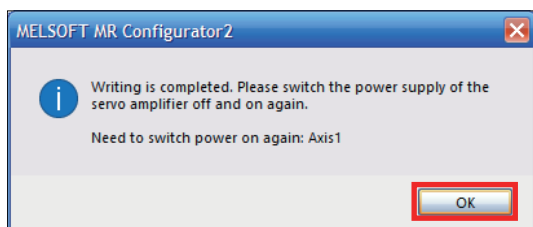

**Point** 

---

After writing of all parameters is completed, turn the power to the overall system OFF and back ON.

---

# 2.11 Enabling the Safety Settings (Safety Remote I/O Module)

Perform the safety module enable process with GX Works3.

Execute the process in the order shown below.

[Start of checking the module position]

↓

[Stop of checking the module position]

↓

[Error history clear request]

↓

[Safety module validation]

## Start of checking the module position

### Operating procedure

1. Display the [Module Parameter] window.

Navigation window ⇒ [Parameter] ⇒ [Module Information] ⇒ [RD78G4] ⇒ Double-click [Module Parameter (Network)]

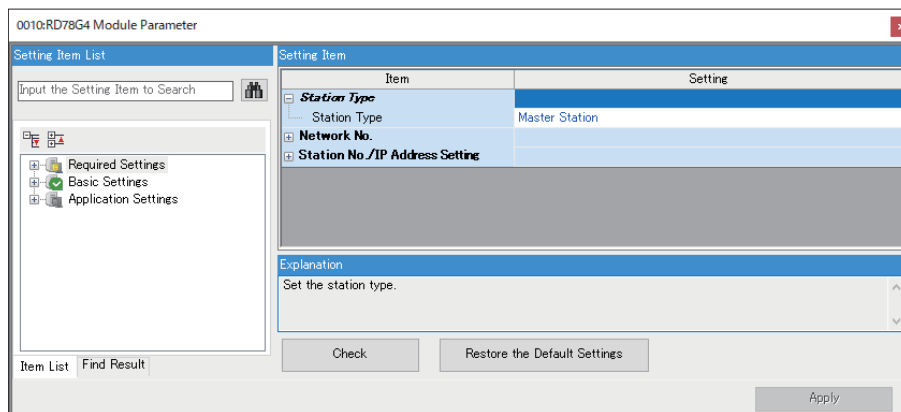

2. Display the CC-Link IE TSN configuration window.

[Basic Settings] ⇒ [Network Configuration Settings] ⇒ Double-click [Detailed Setting]

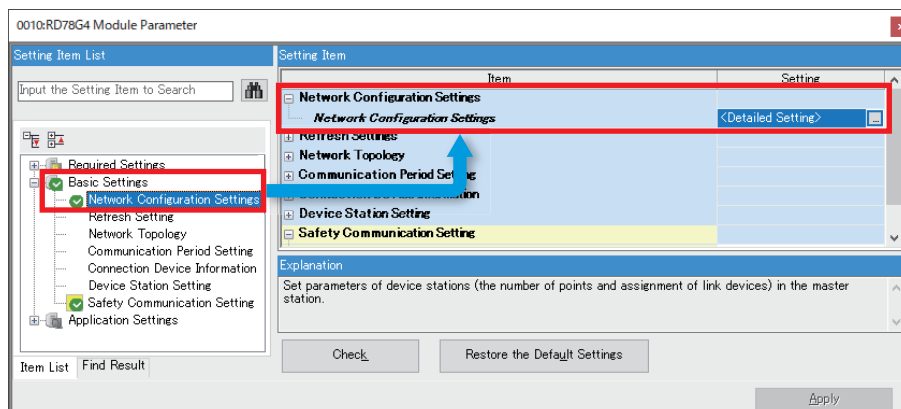

**3.** Display the [Command Execution of Device Station] window.

Right-click on [NZ2GNSS2-16DTE]. ⇒ [Online] ⇒ [Command Execution of Device Station]

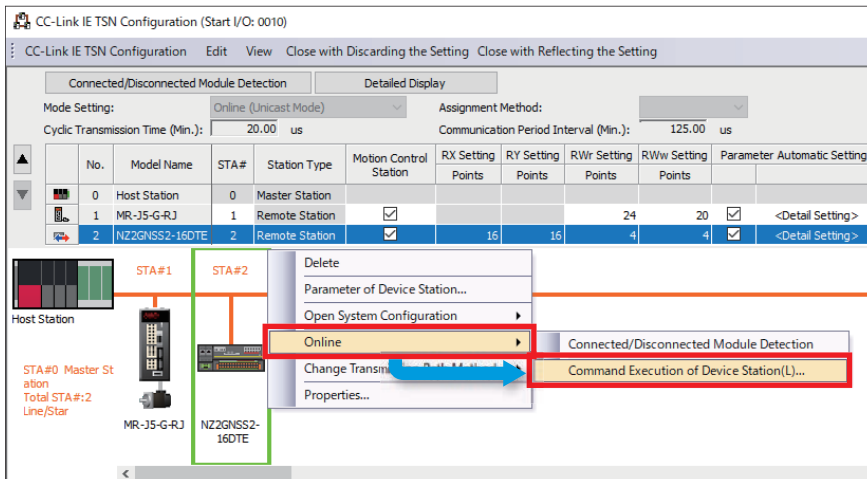

**4.** Select [Start of checking the module position] for [Method selection], then click [Execute].

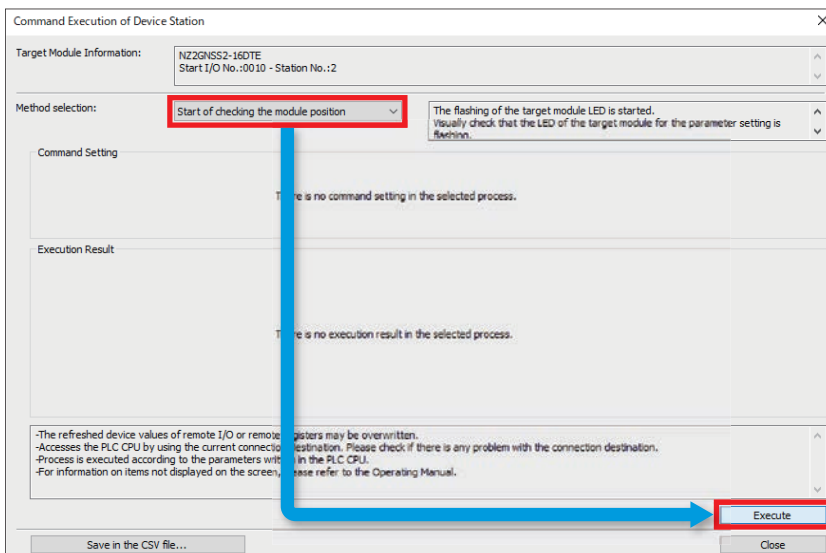

**5.** An execution confirmation window for the selected process appears. Click [Yes].

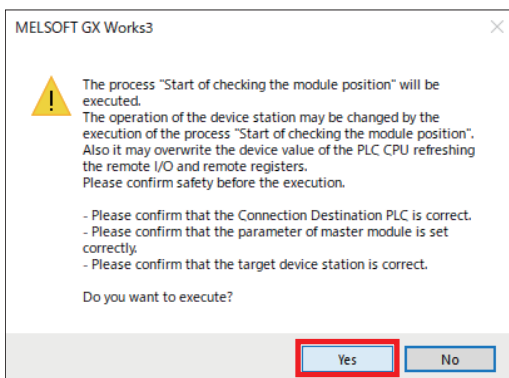

6. A user authentication window appears. Enter the password and click [OK].

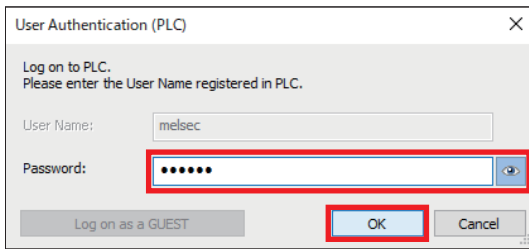

7. A process execution completion window appears. Click [OK].

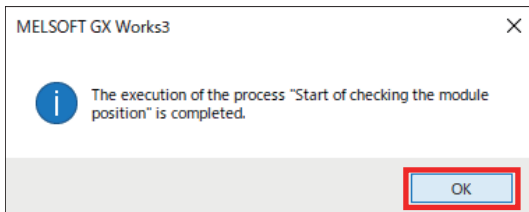

8. Check that SAFETY.LED on the main unit is flashing.

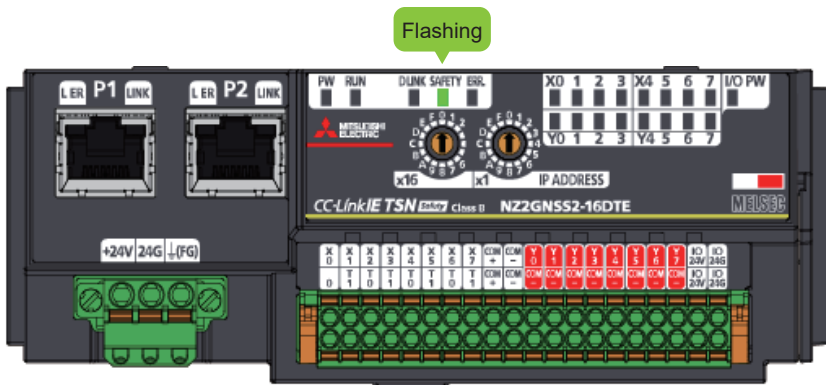

#### Point

If the NZ2GNSS2-16DTE SAFETY.LED is not flashing, check the following.

- Is the module power ON?
- Is the module IP address setting (rotary switch) correct?
- Is the Ethernet cable connected correctly?

## Stop of checking the module position

### Operating procedure

1. Select [Stop of checking the module position] for [Method selection], then click [Execute].

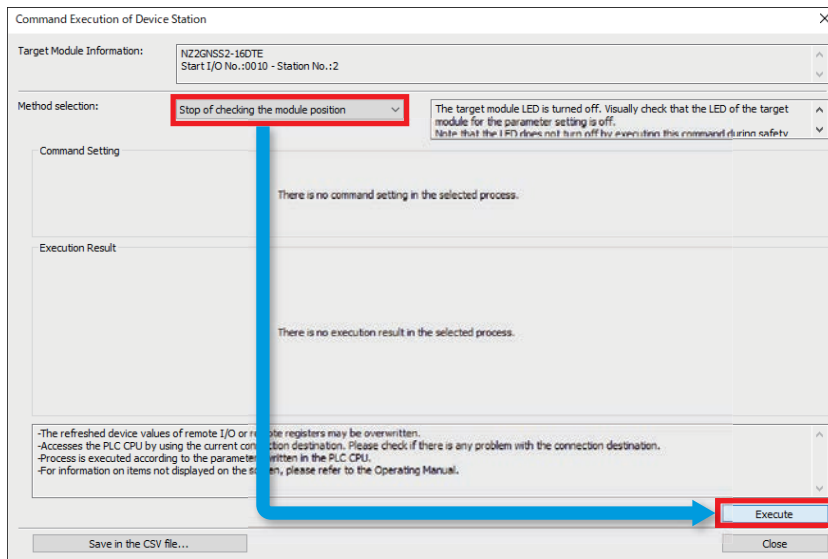

2. An execution confirmation window for the selected process appears. Click [Yes].

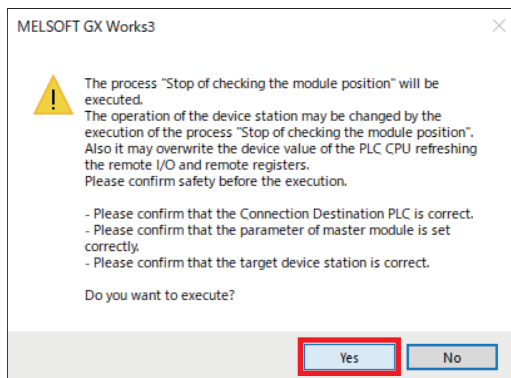

3. A process execution completion window appears. Click [OK].

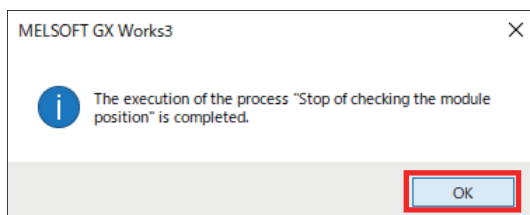

# Error history clear request

## Operating procedure

1. Select [Error history clear request] for [Method selection], then click [Execute].

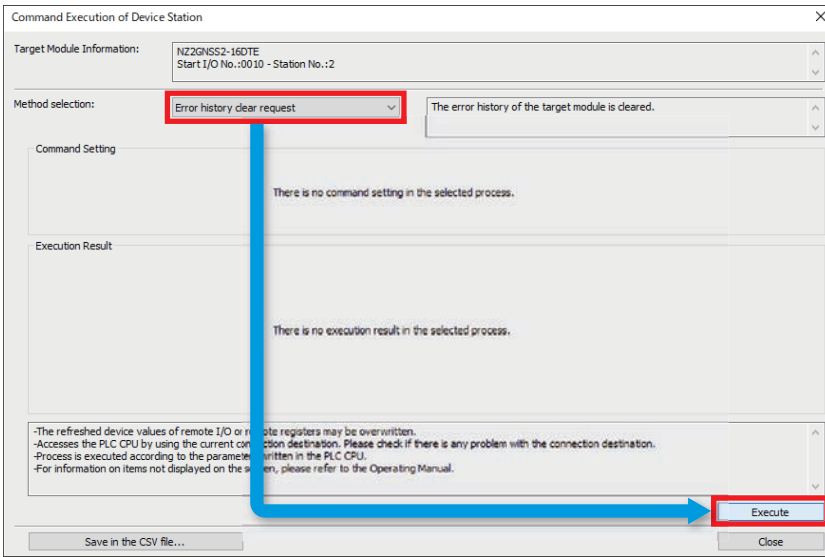

2. An execution confirmation window for the selected process appears. Click [Yes].

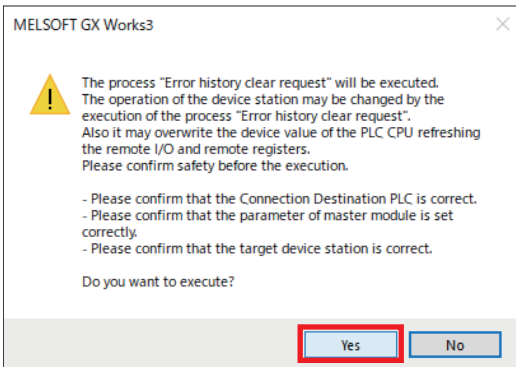

3. A process execution completion window appears. Click [OK].

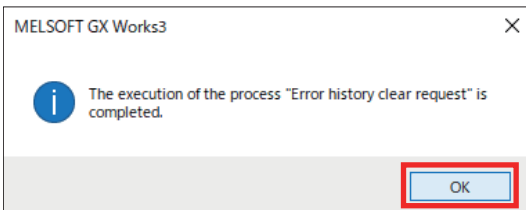

# Safety module validation

## Operating procedure

1. Select [Safety module validation] for [Method selection], then click [Execute].

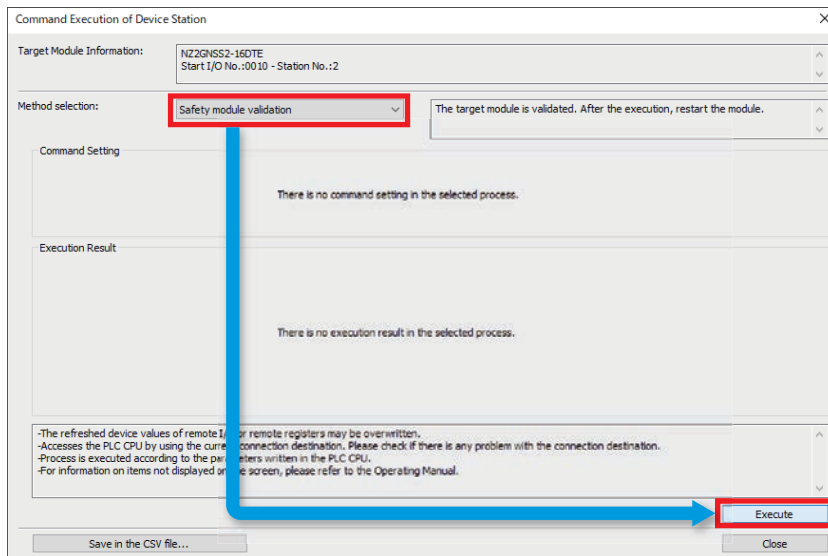

2. A confirmation window appears. Click [Yes].

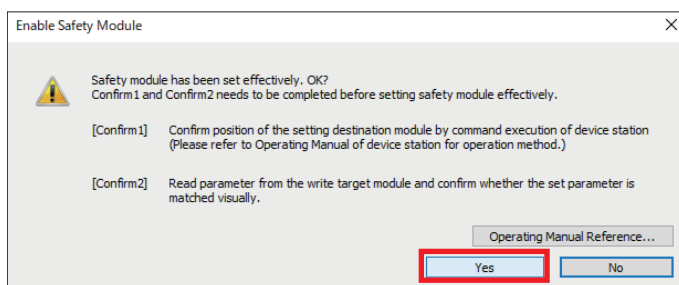

3. An execution confirmation window for the selected process appears. Click [Yes].

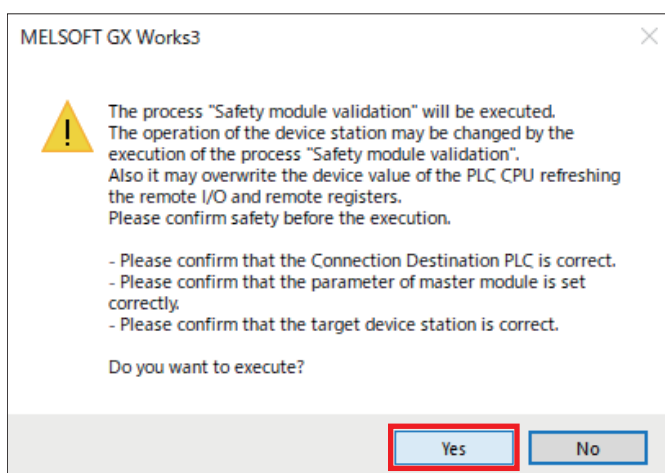

4. A process execution completion window appears. Click [OK].

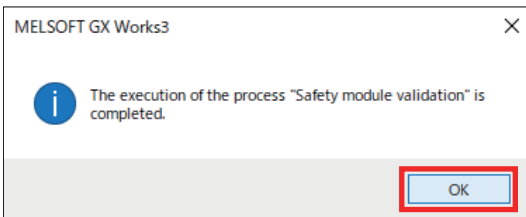

5. Click [Close].

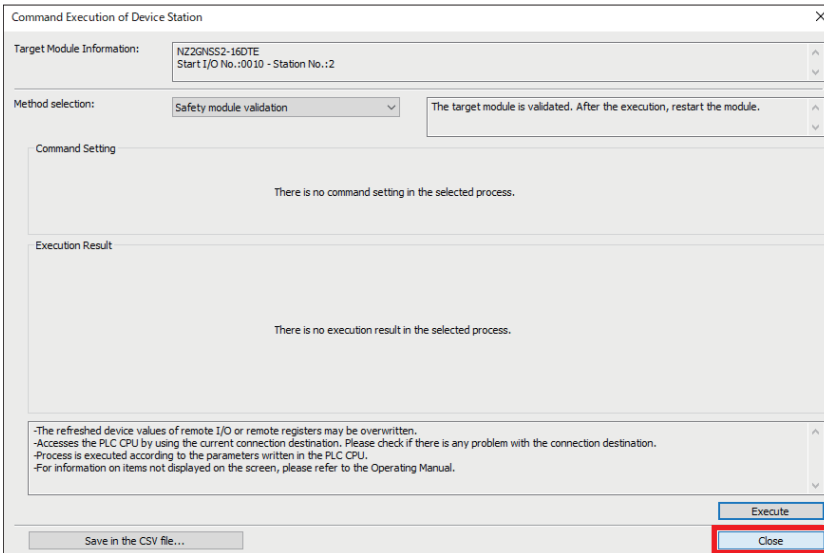

6. Click [Close with Reflecting the Setting] on the [CC-Link IE TSN Configuration] window to apply the configuration.

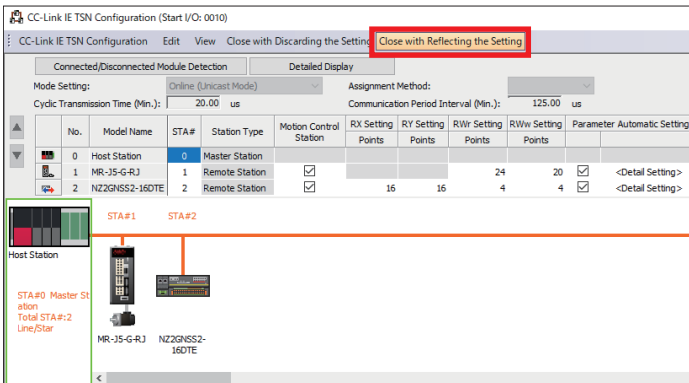

7. If the window shown below appears, click [Yes].

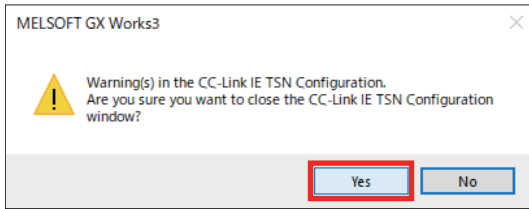

**Point** 

---

After the [Safety module validation] process is completed, turn the power to the overall system OFF and back ON.

---

# 3 Operation Check

## 3.1 Communication with the Safety Remote I/O Module

Check the status of communication with the safety remote I/O module.

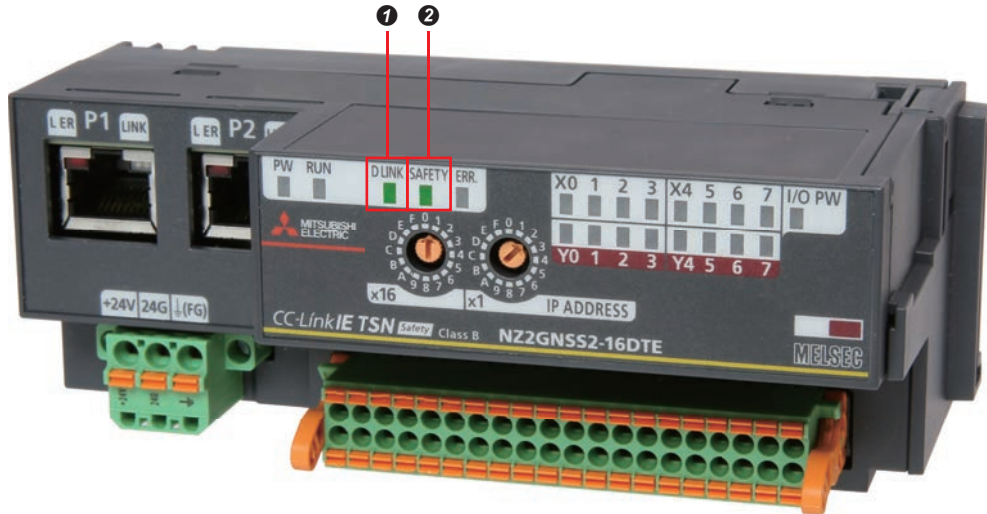

- ❶ "D LINK" illuminates when the network configuration is written.
- ❷ "SAFETY" illuminates when safety systems are enabled.

## 3.2 Checking that Safety Communication Settings were Completed Correctly

When the safety communication settings are written correctly, the servo amplifier display (3-digit, 7-segment LED) shows the normal display.

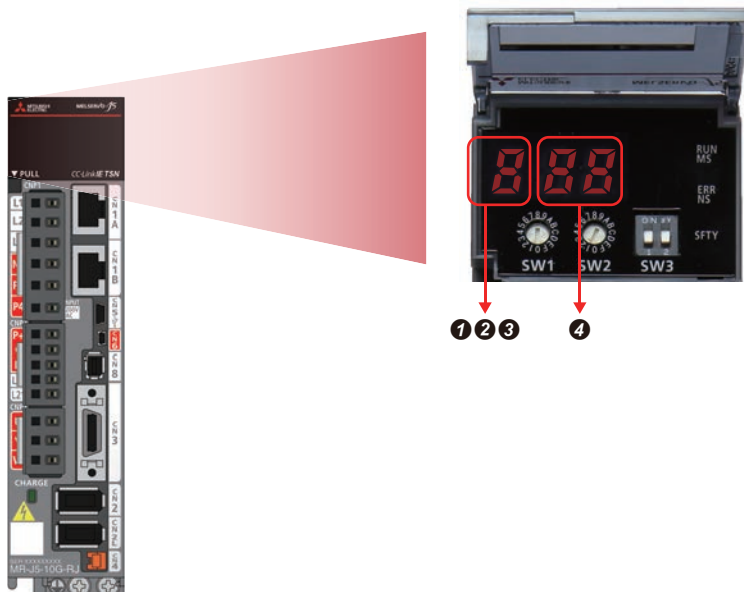

- ❶ "b": Indicates ready-off, servo-off status.
- ❷ "c": Indicates ready-on, servo-off status.
- ❸ "d": Indicates ready-on, servo-on status.
- ❹ The segments of the last two digits indicate the station number.

## 3.3 Safety Monitoring Operation Check

Check the operating status of safety speed monitoring (SLS1), safety rotation direction monitoring (SDI), and safety torque cut-off (STO).

### Preparation for operation check

#### ■Creating a program

The explanation here uses an example of a sample program.

For information about the sample example, refer to “[Page 95 Sample Program.](#)”

Open the sample program with GX Works3 and write it to the programmable controller. User authentication is required when launching the sample program. Enter the user name and password listed below. For details of the writing procedure, refer to “[Page 60 Program Writing.](#)”

#### User authentication

User name: melsec

Password: melsec



When a user creates a program, it is necessary to register an FB library in advance. For information about library registration, refer to “[Page 93 Library Registration.](#)”

#### ■Checking the switch wiring

Check whether wiring has been connected to the switches on the safety remote I/O module.

#### ■Checking the USB connection

Check whether the R16SFCPU and MR-J5-G-RJ have been connected to the PC by USB.

### Monitor start

Monitoring is performed by both GX Works3 and MR Configurator2.



Check that the CPU module is running.

#### ■GX Works3 monitor start

[Online] ⇒ [Monitor] ⇒ [Start Monitoring (All Windows)]

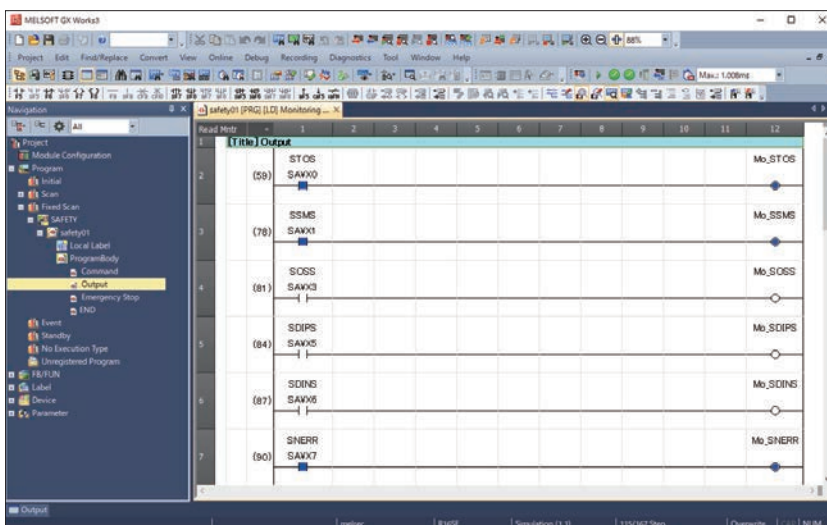

## MR Configurator2 monitor start

[Monitor] ⇨ [Display All]

No.	Item	Unit	Axis1
1	Cumulative feedback pulses	pulse	124443
2	Servo motor speed	r/min mm/s	0
3	Droop pulse	pulse	8
4	Cumulative cmd. pulses	pulse	-3187
5	Command pulse frequency	kpulse/s	0
6	Regenerative load ratio	%	0
7	Effective load ratio	%	0
8	Peak load ratio	%	0
9	Torque/Instantaneous torque	%	0
10	Within one-revolution position	pulse	3012173
11	ABS counter	rev	-26023
12	Load inertia moment ratio	times	3.34
13	Bus voltage	V	275
14	Load side encoder cumulative F/B pulses	pulse	0
15	Load side droop pulses	pulse	0
16	Load side encoder information 1		3012173
17	Load side encoder information 2		-26023
18	Servo motor thermistor temperature	°C	9999
19	Cumulative feedback pulses (Motor unit)	pulse	124443
20	Electrical angle	pulse	3012158
21	Servo motor/load side position difference	pulse	0
22	Servo motor/load side speed difference	r/min	0
23	Internal temperature of encoder	°C	49

[Diagnosis] ⇨ [Alarm Display]

Axis1

No. Name Occurrence time  
 ---- Not generated ----

Additional information:(Alarm reset disable)

Alarm history

	Number	Name	Power-on time [h]	Time
New	582.2	Safety communication error 2 (safety sub-function)	23	12/23/2023 4:26:25 PM
1				
2				
3				
4				
5				
6				

Alarm Occurrence Data    Display Causes Again    Occurred Alarm Reset

Alarm/Warning List    Clear

## Safety speed monitoring (SLS1) operation check

If the servo motor speed reaches 200 or higher while the SLS1 function is operating, the STO function activates and stops the motor.

### Operating procedure

#### 1. Press the forward switch (X2).

When the forward switch (X2) turns ON, safety speed monitoring (SLS1) and safety rotation direction monitoring (SDI) are enabled.

The servo motor rotates in the forward direction.

- Checking the SLS1 command (GX Works3)

Navigation window ⇒ [Program] ⇒ [Fixed Scan] ⇒ [SAFETY] ⇒ [safety01] ⇒ [ProgramBody] ⇒ [Command]

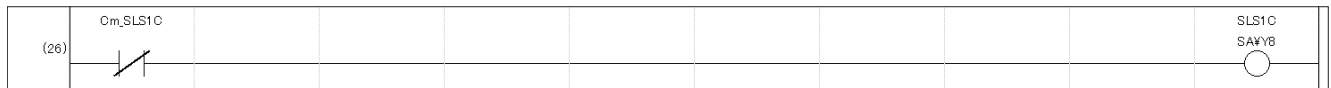

- Checking the operation status of the SOS function (GX Works3)

Navigation window ⇒ [Program] ⇒ [Fixed Scan] ⇒ [SAFETY] ⇒ [safety01] ⇒ [ProgramBody] ⇒ [Output]

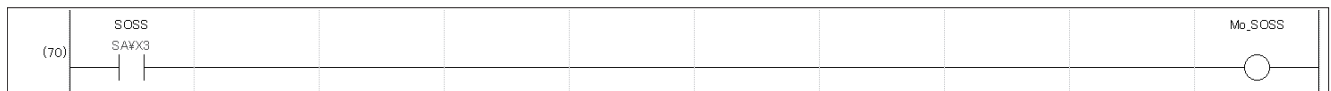

- Checking the servo motor speed (MR Configurator2)

Check that the servo motor speed is "100."

No.	Item	Unit	Axis1
1	Cumulative feedback pulses	pulse	937300945
2	Servo motor speed	r/min mm/s	100
3	Droop pulse	pulse	0
4	Cumulative cmd. pulses	pulse	5873
5	Command pulse frequency	kpulse/s	0

#### 2. Press the accelerate switch (X4).

The motor speed increases by 40 each time the accelerate switch (X4) is pressed.

- Checking the servo motor speed (MR Configurator2)

Check that the servo motor speed increases.

No.	Item	Unit	Axis1
1	Cumulative feedback pulses	pulse	51063061
2	Servo motor speed	r/min mm/s	140
3	Droop pulse	pulse	0
4	Cumulative cmd. pulses	pulse	5873
5	Command pulse frequency	kpulse/s	0



No.	Item	Unit	Axis1
1	Cumulative feedback pulses	pulse	208153847
2	Servo motor speed	r/min mm/s	180
3	Droop pulse	pulse	0
4	Cumulative cmd. pulses	pulse	5873
5	Command pulse frequency	kpulse/s	0

### 3. Activation of the STO function

If the servo motor speed reaches 200 or higher, the STO function activates due to excessive SLS1 speed.

In the program, the STO status (SA#X0) contact is ON, so the STO function is activated\*1.

\*1 SSM (within SSM speed) and SNERR (safety communication error) also occur.

- SSM: Output that turns ON when within the specified speed
- SNERR: Output that turns ON when a communication error occurs (It may also turn ON when a servo amplifier alarm occurs.)
- Checking the operation status of the STO function (GX Works3)

Navigation window ⇒ [Program] ⇒ [Fixed Scan] ⇒ [SAFETY] ⇒ [safety1] ⇒ [ProgramBody] ⇒ [Output]

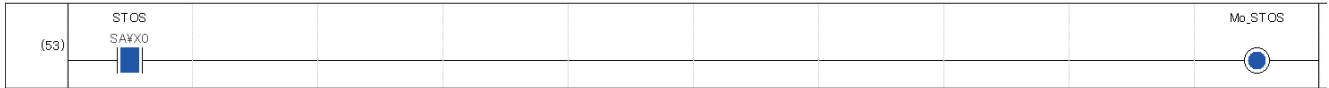

### 4. An alarm (AL.561.2) occurs at the servo amplifier.

The LEDs are indicated as shown below.

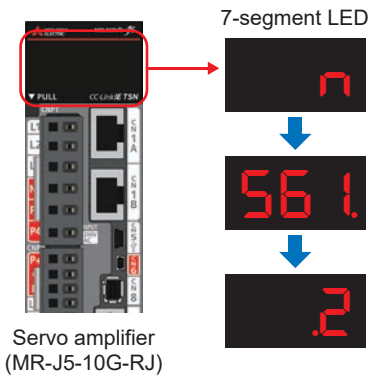

Servo amplifier (MR-J5-10G-RJ)

### 5. Checking the alarm details (MR Configurator2)

[Diagnosis] ⇒ [Alarm Display]

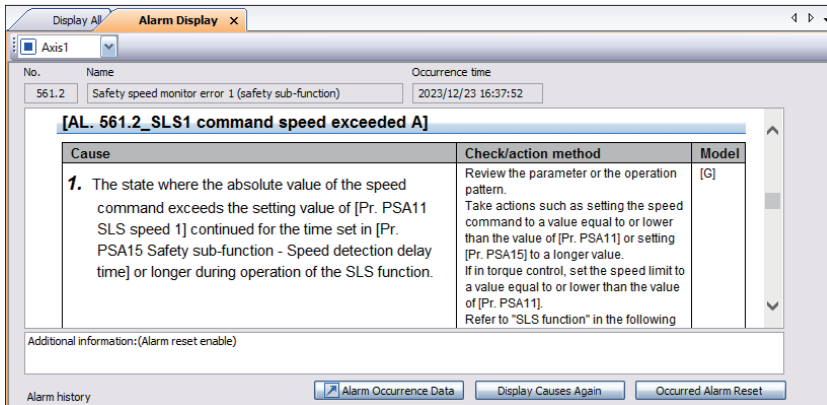

### 6. Press the reset switch (X5) to cancel the alarm.

## Safety direction monitoring (SDI) operation check

If the servo motor rotates in the reverse direction for a certain period of time\*<sup>1</sup> while the SDI function is operating, the STO function activates and stops the motor.

\*<sup>1</sup> This is determined by Pr. PSA28, the SDI reverse direction monitoring delay time. Here it is set to 1000 ms (default).

### Operating procedure

#### 1. Press the reverse switch (X3).

When the reverse switch (X3) is ON, safety direction monitoring (SDI) is enabled.

The servo motor rotates in the reverse direction.

#### Point

With the current parameter settings, the servo motor rotates in the reverse direction for approximately 1 second.

- Checking the SDIN command (GX Works3)

Navigation window ⇒ [Program] ⇒ [Fixed Scan] ⇒ [SAFETY] ⇒ [safety01] ⇒ [ProgramBody] ⇒ [Command]

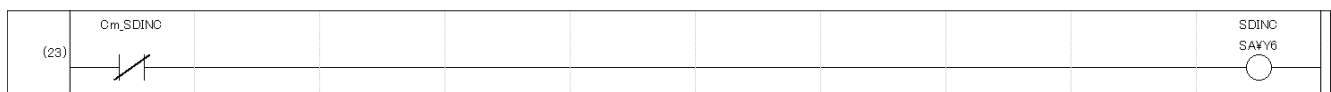

- Checking the SDIN output (GX Works3)

Navigation window ⇒ [Program] ⇒ [Fixed Scan] ⇒ [SAFETY] ⇒ [safety01] ⇒ [ProgramBody] ⇒ [Output]

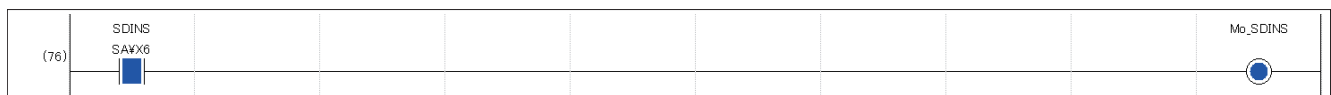

- Checking the servo motor speed (MR Configurator2)

Check that the servo motor speed is “-100.”

No.	Item	Unit	Axis1
1	Cumulative feedback pulses	pulse	197992965
2	Servo motor speed	r/min mm/s	-100
3	Droop pulse	pulse	0
4	Cumulative cmd. pulses	pulse	6512
5	Command pulse frequency	kpulse/s	0

#### 2. Activation of the STO function

When the motor rotates in the reverse direction for 1 second or longer, safety direction monitoring activates the STO function.

In the program, the STO status (SA#X0) contact is ON, so the STO function is activated\*<sup>1</sup>.

\*<sup>1</sup> SSMS (SSM output) and SNERR (safety communication error) also occur.

- SSMS: Output that turns ON when within the specified speed
- SNERR: Output that turns ON when a communication error occurs (It may also turn ON when a servo amplifier alarm occurs.)

- Checking the operation status of the STO function (GX Works3)

Navigation window ⇒ [Program] ⇒ [Fixed Scan] ⇒ [SAFETY] ⇒ [safety1] ⇒ [ProgramBody] ⇒ [Output]

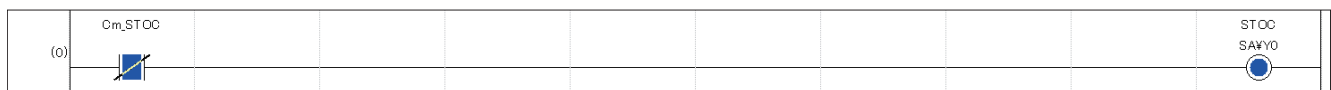

**3.** An alarm (AL.565.3) occurs at the servo amplifier.

The LEDs are indicated as shown below.

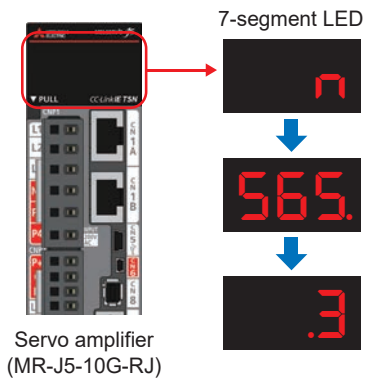

**4.** Checking the alarm details (MR Configurator2)

[Diagnosis] ⇄ [Alarm Display]

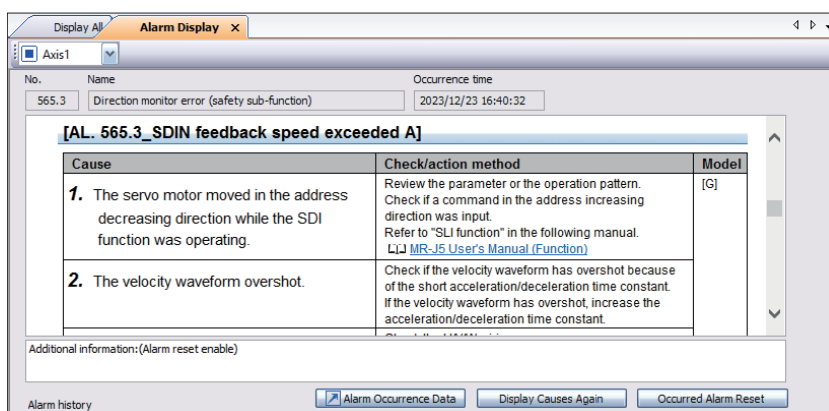

**5.** Press the reset switch to cancel the alarm.

## Safety deceleration monitor (SS1)

If the servo motor speed drops below the stop speed<sup>\*1</sup> while the SS1 function is operating, the STO function activates and stops the motor.

\*1 This is determined by the setting of Pr. PSA04, safety sub-function stop speed. Here it is set to 50 (default).

### Operating procedure

#### 1. Press the forward switch (X2).

When the forward switch (X2) is ON, safety deceleration monitoring (SS1) is enabled.

The servo motor rotates in the forward direction.

- Checking the SS1 command (GX Works3)

Navigation window ⇒ [Program] ⇒ [Fixed Scan] ⇒ [SAFETY] ⇒ [safety01] ⇒ [ProgramBody] ⇒ [Command]

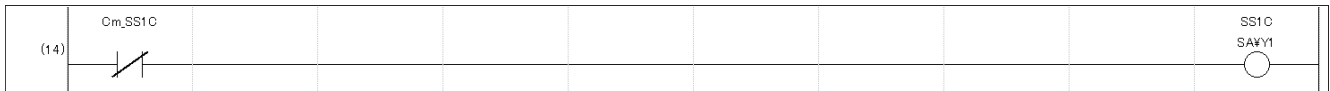

- Checking the operation status of the SS1 function (GX Works3)

Navigation window ⇒ [Program] ⇒ [Fixed Scan] ⇒ [SAFETY] ⇒ [safety01] ⇒ [ProgramBody] ⇒ [Output]

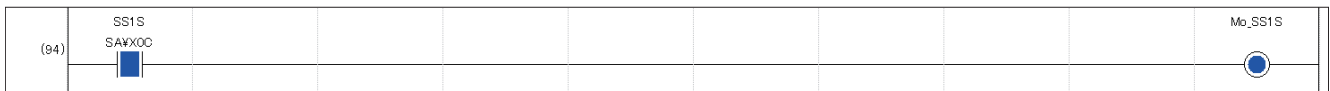

- Checking the servo motor speed (MR Configurator2)

Check that the servo motor speed is "100."

No.	Item	Unit	Axis1
1	Cumulative feedback pulses	pulse	937300945
2	Servo motor speed	r/min mm/s	100
3	Droop pulse	pulse	0
4	Cumulative cmd. pulses	pulse	5873
5	Command pulse frequency	kpulse/s	0

#### 2. Press the emergency stop switch.

#### 3. Activation of the STO function

When the emergency stop switch is pressed and the servo motor speed drops to 50 or less, the safety deceleration monitor activates the STO function. In the program, the STO status (SA#X0) contact is ON, so the STO function is activated<sup>\*1</sup>.

\*1 SSMS (SSM output) also occurs.

- SSMS: Output that turns ON when within the specified speed

- Checking the operation status of the STO function (GX Works3)

Navigation window ⇒ [Program] ⇒ [Fixed Scan] ⇒ [SAFETY] ⇒ [safety1] ⇒ [ProgramBody] ⇒ [Output]

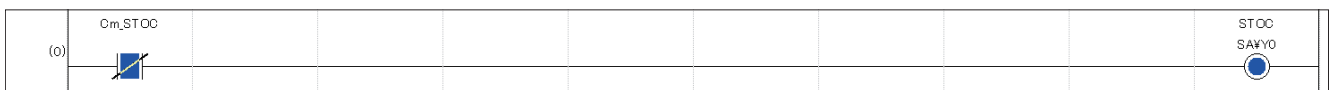

**4.** An alarm (AL.596.1) occurs at the servo amplifier.

The LEDs are indicated as shown below.

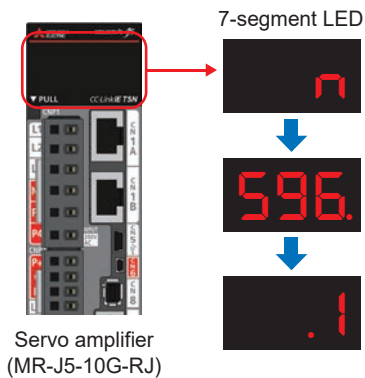

**5.** Checking the alarm details (MR Configurator2)

[Diagnosis] ⇄ [Alarm Display]

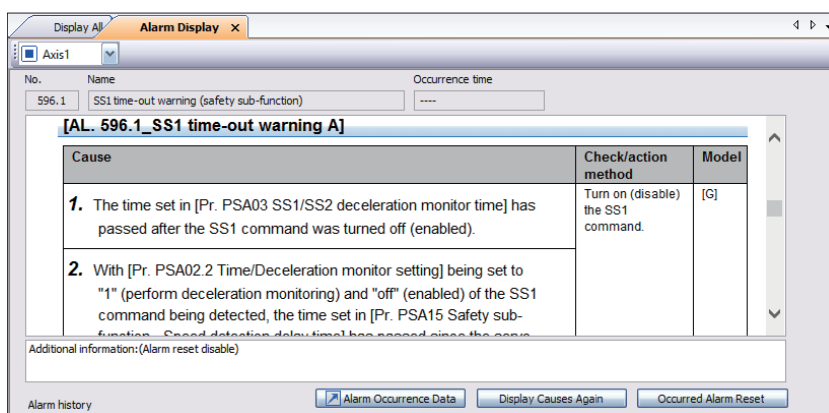

**6.** Press the reset switch (X5) to cancel the alarm.

# 4 Troubleshooting

## 4.1 Segment LED Displays and Contents

The servo amplifier communication status, IP address, and errors can be checked on the servo amplifier display (3-digit, 7-segment LED).

### Display flow

The following explains the flow from after the servo amplifier power supply is turned ON until the 7-segment LED is displayed. After systems check is completed and the servo amplifier starts, the network connection status is displayed.

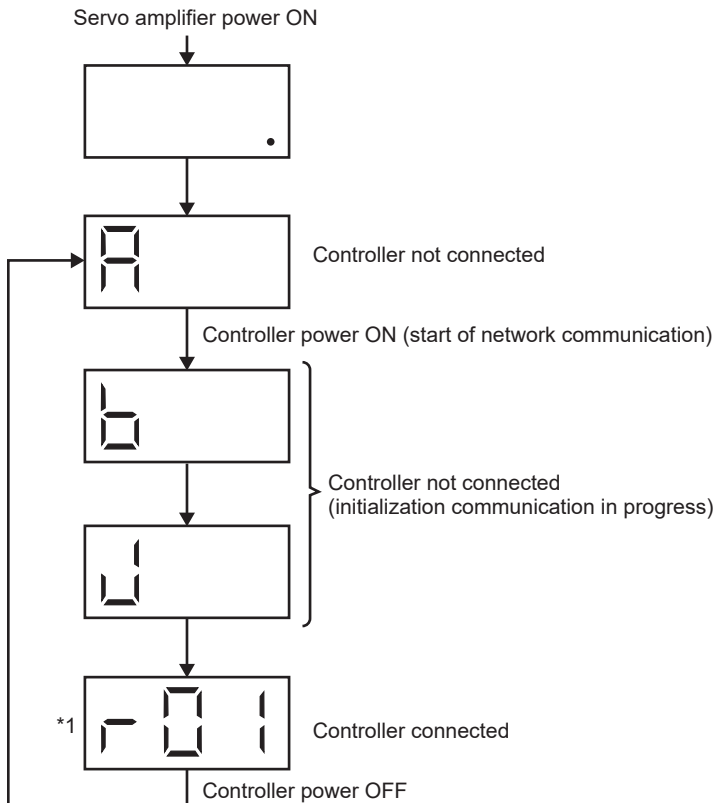

\*1 The segments of the last two digits indicate the IP address.  
For details of the connection status display, refer to "Page 89 When connected to a network."

### Alarm display

When an alarm or warning occurs, the network connection status is displayed, followed by the status of alarm occurrence. The following is an example when [AL.032.2 Overcurrent] occurred.

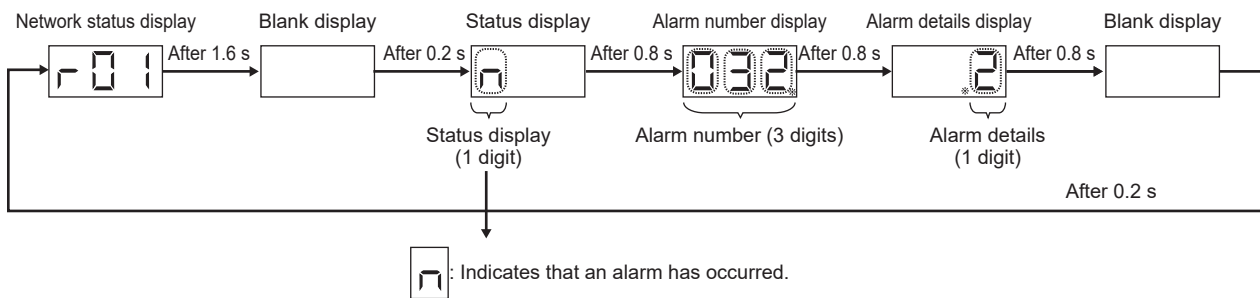

## When connected to a network

The network connection status is displayed as shown below. The decimal point indicates the servo amplifier status.

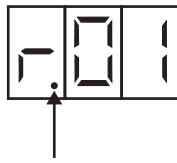

Servo amplifier status

OFF: Indicates ready-off, servo-off status.  
 Flashing: Indicates ready-on, servo-off status.  
 Lit: Indicates ready-on, servo-on status.

The last two digits indicate the address for that network.

Network	Address
CC-Link IE TSN	The IP address is indicated in hexadecimal notation.

## Display contents

The display contents are shown below.

LED display	Status	Description
A	Initializing	Controller not connected
b c d E F	Initializing	Data link not performed: Performing initial CC-Link IE TSN communication
H	Initializing	Cyclic communication in progress: Pre-Operational status in the NMT state machine status transition diagram
U	Initializing	Cyclic communication in progress: Safe-Operational status in the NMT state machine status transition diagram
Y	Initializing	Cyclic communication stopped: Reserved station status
r.01 <sup>*1</sup>	Servo-off, ready-off	Controller connecting
r*.01 <sup>*1</sup>	Servo-off, ready-on	The servo-off command was received from the controller.
r.01 <sup>*1</sup>	Servo-on	The servo-on command was received from the controller.
n	Alarm occurring	An alarm or warning has occurred at the servo amplifier.
n 888. 8	Alarm and warning	The occurred alarm number and warning number are displayed.
888	CPU error	A CPU module watchdog error has occurred.
r5r	Test operation mode <sup>*2</sup>	This is set for jog operation, positioning operation, program operation, output signal (DO) forced output, or operation without motor.

\*1 The "01" following the r is the last two digits of the IP address.



\*2 MR Configurator2 is required.

## 4.2 Errors and Corrective Actions

The causes and corrective actions for alarms that occurred at the servo amplifier are shown below.

For alarms other than those listed below, refer to the following.

 MR-J5 User's Manual (Troubleshooting)

No.	Name	Cause	Corrective action
AL. 537.1	Parameter setting range error A (safety sub-function)	There is a functional safety parameter that was set outside the setting range.	Check the parameter error number on the MR Configurator2 alarm display window or elsewhere, and review the setting of the functional safety parameter.
AL. 537.2	Parameter combination error A (safety sub-function)	A servo parameter or functional safety parameter is not set correctly.	Check the parameter error number on the MR Configurator2 alarm display window or elsewhere, and review the setting of the servo parameter or functional safety parameter. Refer to "Parameter combinations that trigger [AL. 537.2 Parameter combination error A (safety sub-function)]" in the following manual.  MR-J5 User's Manual (Function)
AL. 537.3	Parameter setting error A (safety sub-function)	A functional safety parameter could not be set correctly.	Check the parameter error number on the MR Configurator2 alarm display window or elsewhere, and review the setting of the functional safety parameter.
AL. 537.A	Parameter combination error B (safety sub-function)	There is an error in the functional safety parameter setting.	Check the parameter where there is an error on MR Configurator2, and set the parameter correctly.
AL. 581.1	Safety communication error 1 Received data error A1 (safety sub-function)	The safety communication settings of the safety master station are not set correctly. There is an error on the safety master station side.	Review the safety communication settings. Refer to "Safety sub-function control by network" in the following manual.  MR-J5 User's Manual (Function) Check whether an alarm has occurred at the safety master station.
AL. 5E2.1	Safety communication not connected warning A (safety sub-function)	Not connected to the controller. The safety communication settings are not set correctly. The IP address was changed after the controller was connected.	Check the cable connections. Review the GX Works3 and MR Configurator2 safety communication settings. Turn the power to the overall system OFF and back ON.
AL. 0E6.1	Forced stop warning	EM2/EM1 turned OFF.	Review the setting of PA04.2, servo forced stop selection.  Page 32 Servo Amplifier

# 5 Switching Safety Operation Mode

## 5.1 Safety operation mode

The Safety CPU has two main operation modes: SAFETY MODE and TEST MODE.  
Change the mode for operation during debugging work and for actual operation.

Safety operation mode	Description
SAFETY MODE	<ul style="list-style-type: none"><li>This is a mode for operating the safety system controlled by the Safety CPU.</li><li>In this mode, Safety CPU safety programs and safety parameters cannot be changed. Only device data values in safety programs can be changed.</li></ul>
TEST MODE	<ul style="list-style-type: none"><li>This is a mode for performing maintenance (such as setting changes and tests) of the safety system controlled by the Safety CPU.</li><li>In this mode, Safety CPU safety programs and safety parameters can be changed. Device data can be changed by performing a device test.</li></ul>

Refer to the following for details.

📖 MELSEC iQ-R Programmable Controller CPU Module User's Manual

## 5.2 How to switch safety operation mode

The safety programmable controller has two control modes: TEST MODE and SAFETY MODE.  
Select TEST MODE when making adjustments to enable editing of the safety program and safety parameters, device tests, and other changes.

### Precautions

Be sure to change to SAFETY MODE for actual operation.

#### Point

Stop the CPU module in advance.

### Operating procedure

1. Use GX Works3 to switch safety operation mode.  
🔗 [Online] ⇒ [Safety PLC Operation] ⇒ [Switch Safety Operation Mode]
2. The [Switch Safety Operation Mode] window appears. Click [Switch].

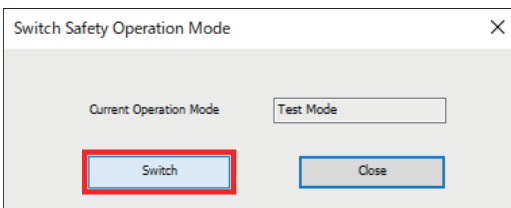

3. A window appears to confirm the change to SAFETY MODE. Check the checkboxes of [Confirmation 1] and [Confirmation 2], then click [Yes].

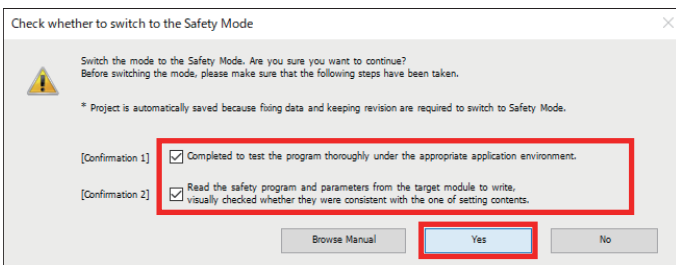

#### Point

If a user authentication message is displayed, follow the instructions on the screen.

4. A SAFETY MODE change completion window appears. Click [OK].

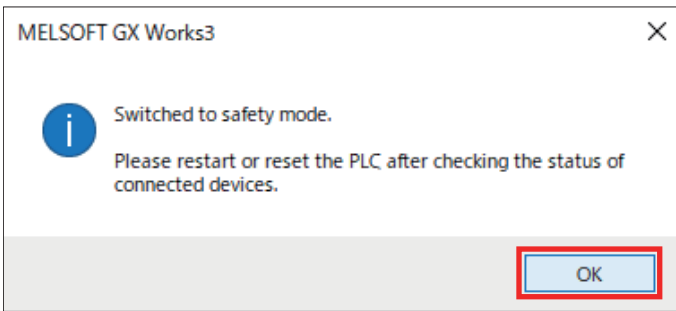

**Point**

If the operation mode cannot be changed, perform the following.

- Change the operating status of the CPU module to STOP.
- Execute again after completing file writing to the CPU module.
- Disable automatic restore.

## 5.3 Checking After Switching Safety Operation Mode

Check with the R6SFM LED TEST.

Immediately after changing, LED TEST flashes (SAFETY MODE (wait-for-restart)).

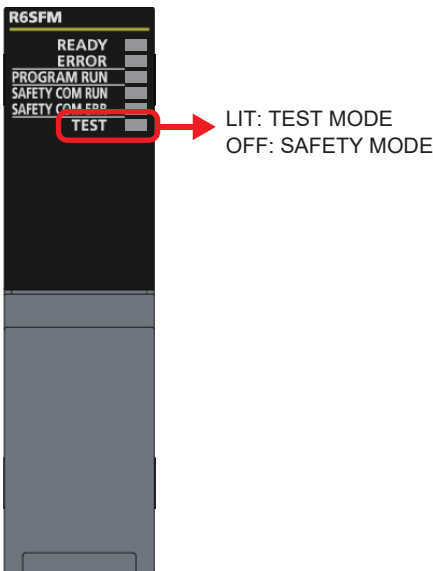

**Point**

After the operation mode was changed at the CPU module, turn the CPU module power supply OFF to ON or else reset the CPU module.

# Appendix

## Appendix 1 Library Registration

This explains the procedure for registering an FB library. This operation is not required when downloading a sample program.

1. Please obtain the motion control FB library (PLCopen Motion Control FB) from Mitsubishi Electric.
2. Uncompress the downloaded archive file (.zip).
3. The element selection is displayed in GX Works3.

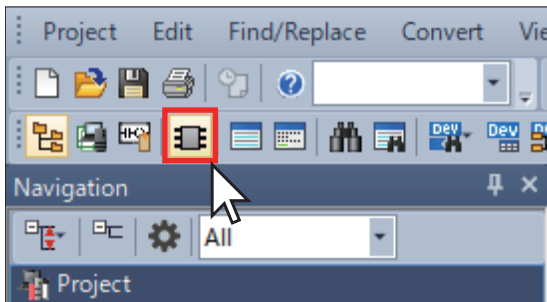

4. From the [Library] tab in the [Element Selection] window, click [Register Library].

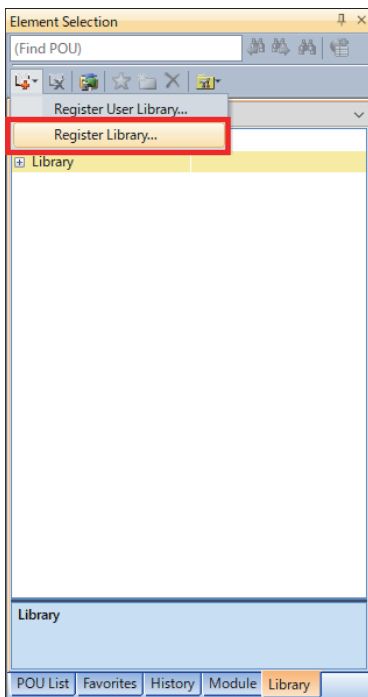

5. Click [OK].

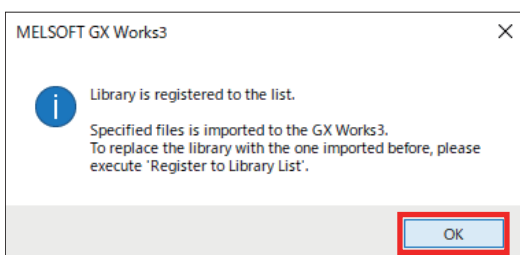

6. Select the uncompressed file "MotionControl\_\*\*\*\*.mslm" and click [Open].

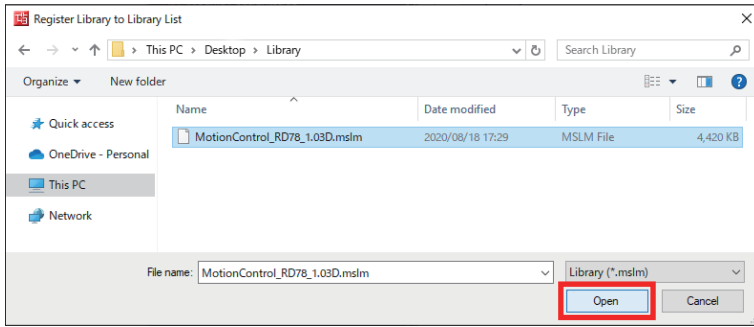

7. The loaded FB is displayed in the [Element Selection] window.



Refer to the following in order to upgrade the version of the FB library.

MELSEC iQ-R Motion Module User's Manual (Application)

# Appendix 2 Sample Program

This explains the sample program ladder and label contents.

## Creating data

### ■Creating a program

Navigation window ⇒ Right-click on [Program]. ⇒ Click [New Data] and create the following program data.

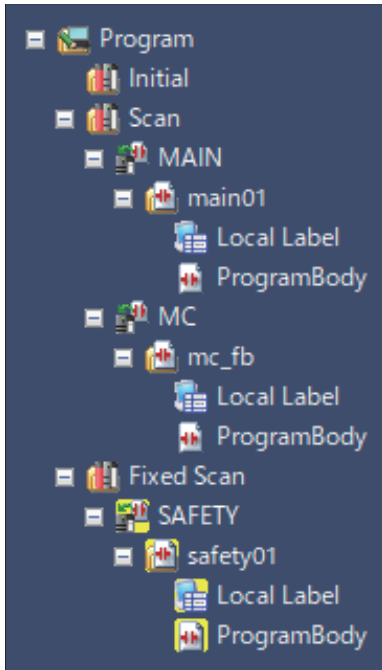

main01 (ladder for drive control)

Item	Setting
Category	General
Data type	Program block
Data name	main01
Program language	Ladder
Execution type	Scan
Add destination program file	MAIN

mc\_fb (FB used for drive control)

Item	Setting
Category	General
Data type	Program block
Data name	mc_fb
Program language	Ladder
Execution type	Scan
Add destination program file	MC

safety01 (ladder for safety control)

Item	Setting
Category	Safety
Data type	Program block
Data name	safety01
Program language	Ladder
Execution type	Fixed Scan
Add destination program file	SAFETY

A

## ■ Global label

Navigation window ⇒ [Label] ⇒ Right-click on [Global Label]. ⇒ Click [New Data] and create the following label.

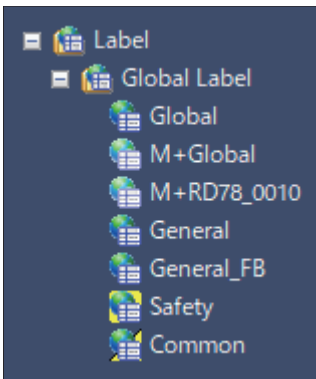

General (label used for drive control)

Item	Setting
Category	General
Data type	Global label
Data name	General

General\_FB (label used for FB)

Item	Setting
Category	General
Data type	Global label
Data name	General_FB

Safety (label used for safety control)

Item	Setting
Category	Safety
Data type	Global label
Data name	Safety

Common (label used for drive control and safety control)

Item	Setting
Category	Common for General/Safety
Data type	Global label
Data name	Common

# Ladder for drive control

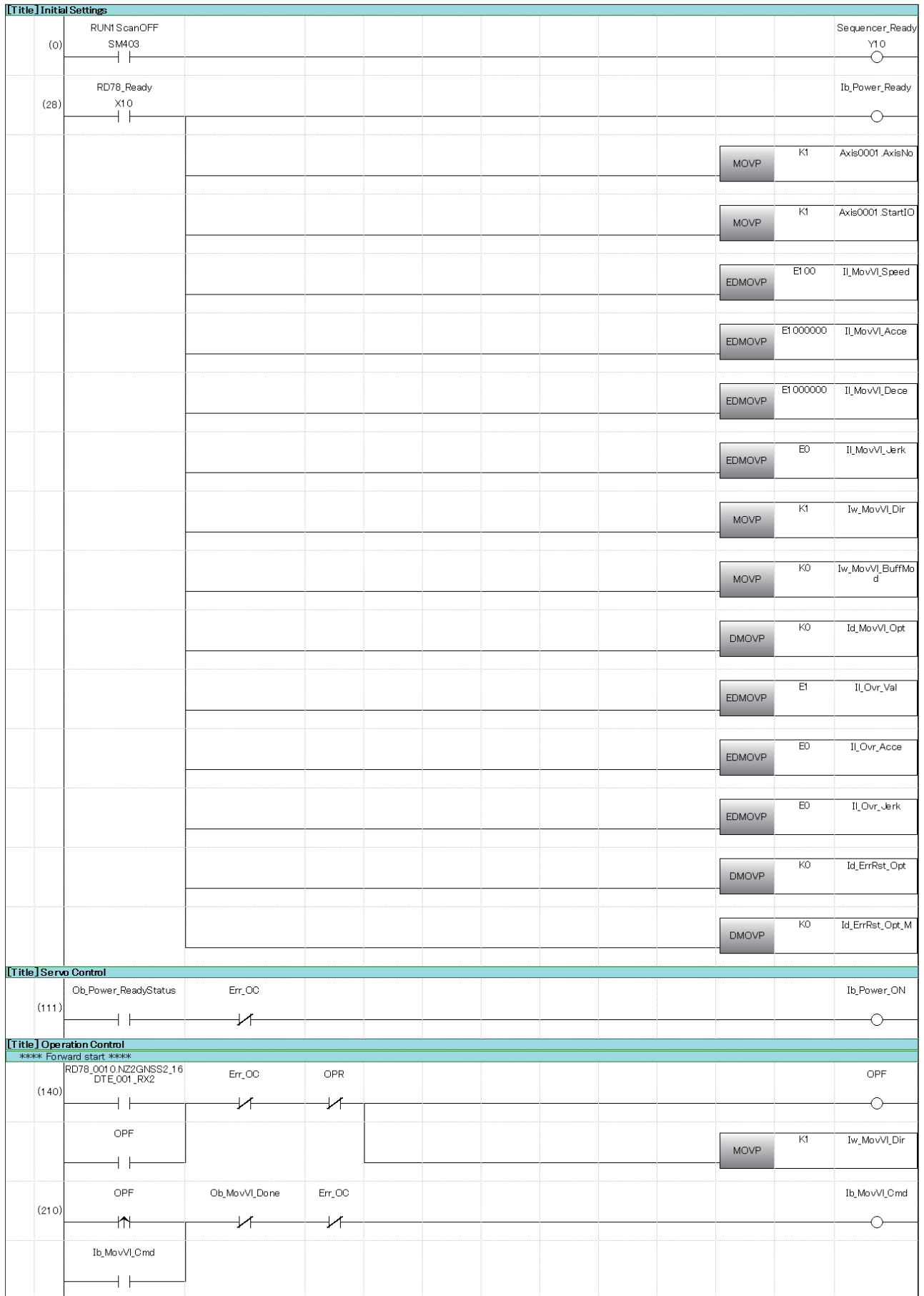

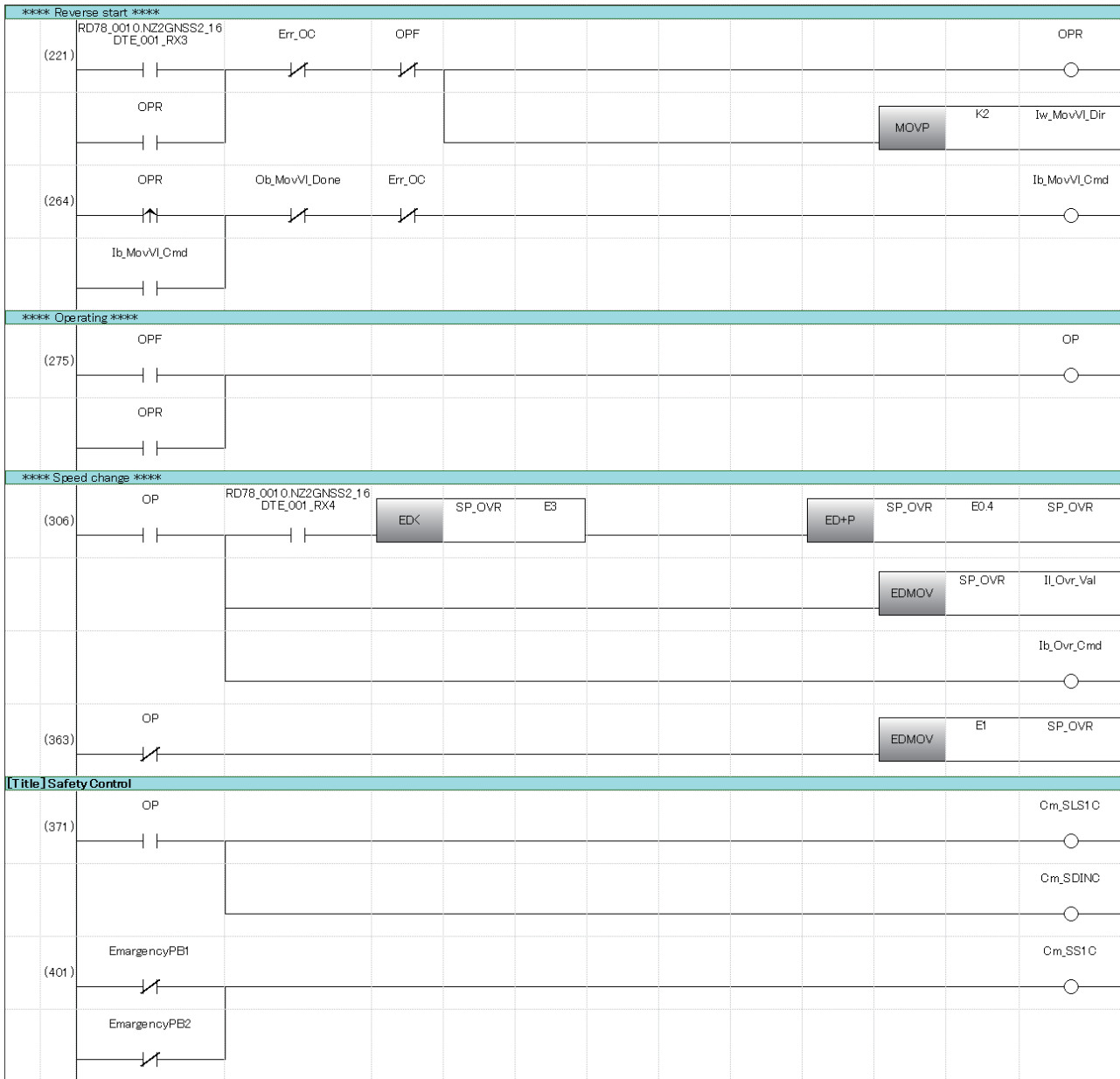



## FB used for drive control

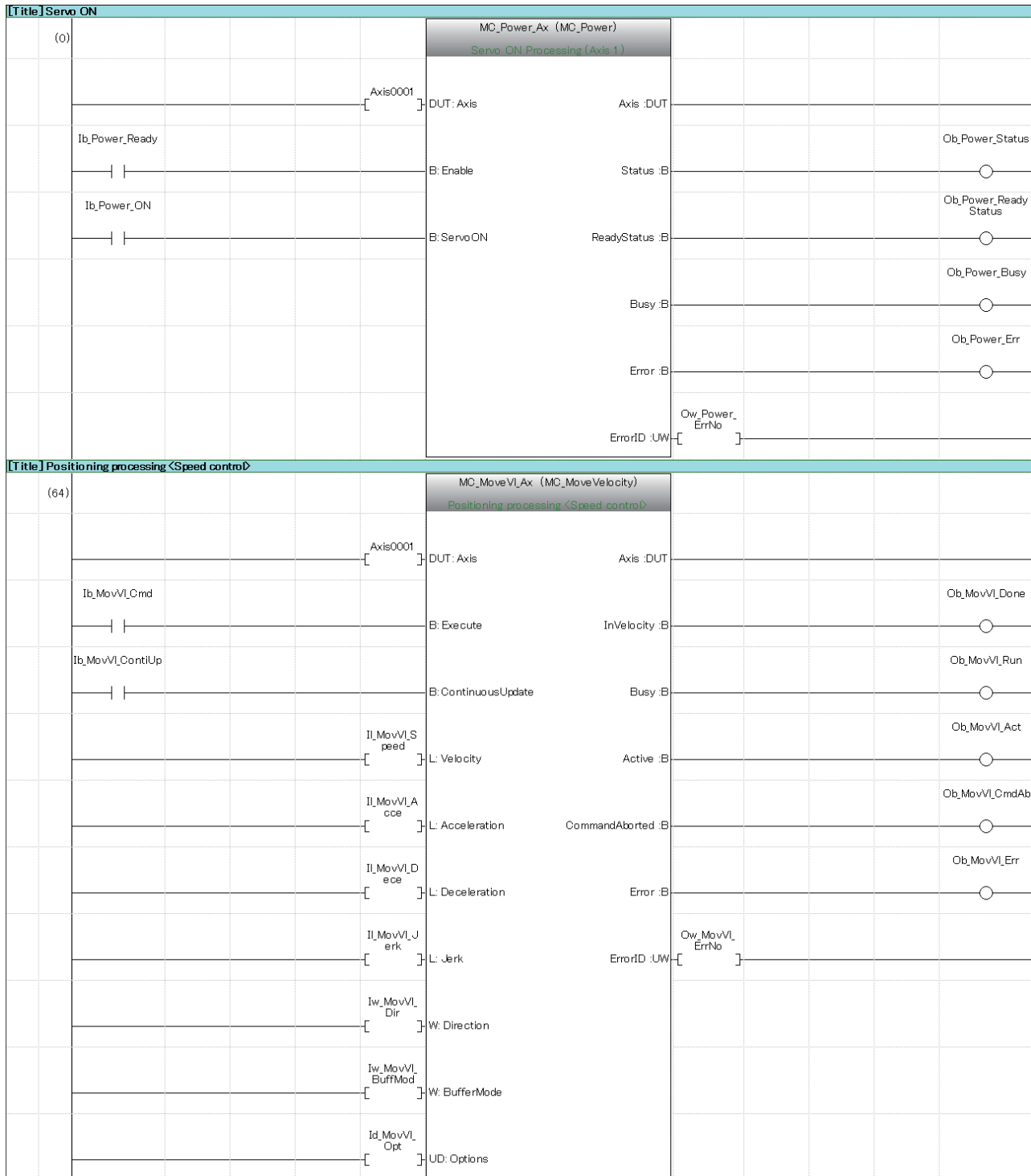

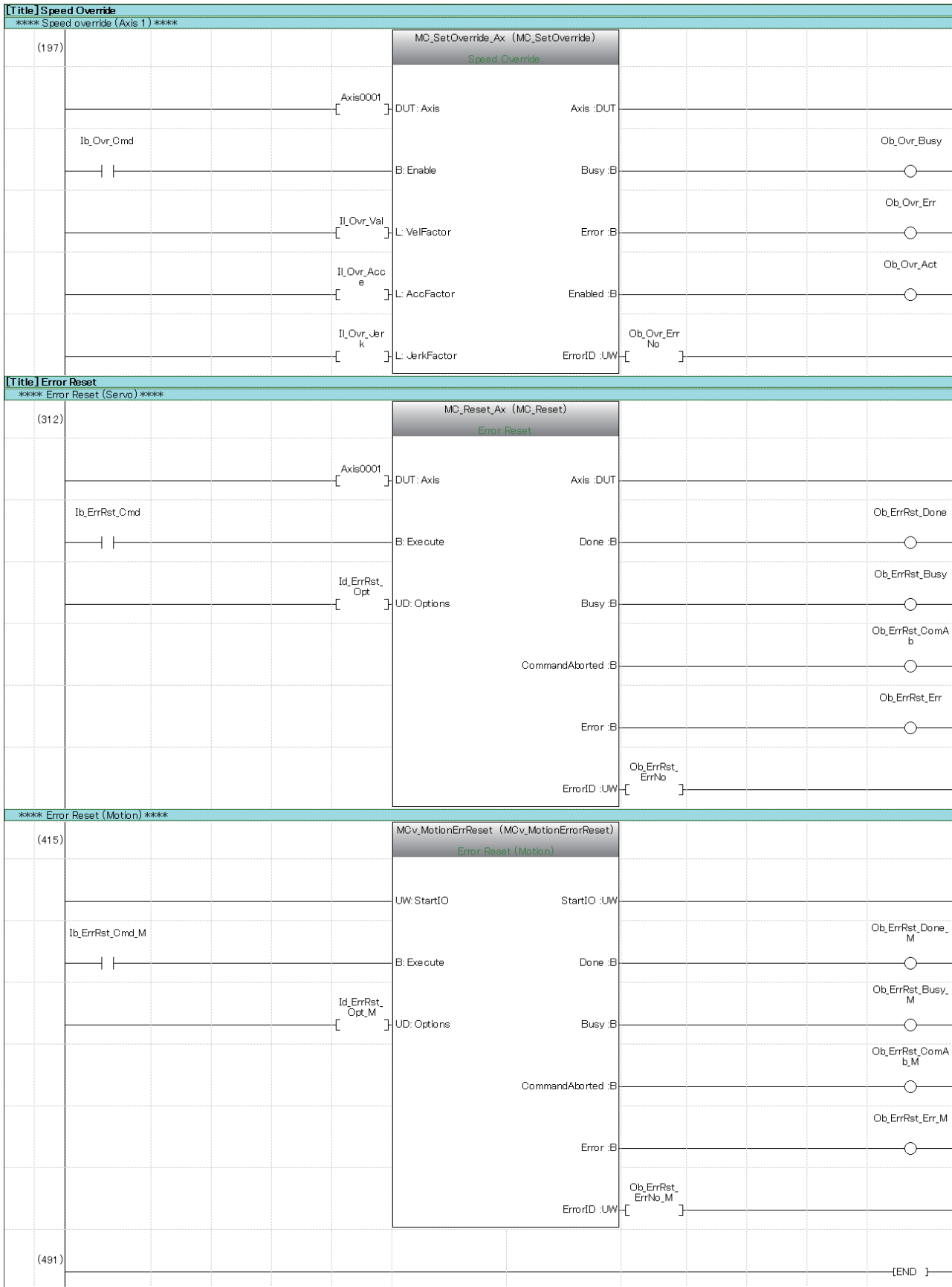

## Ladder for safety control

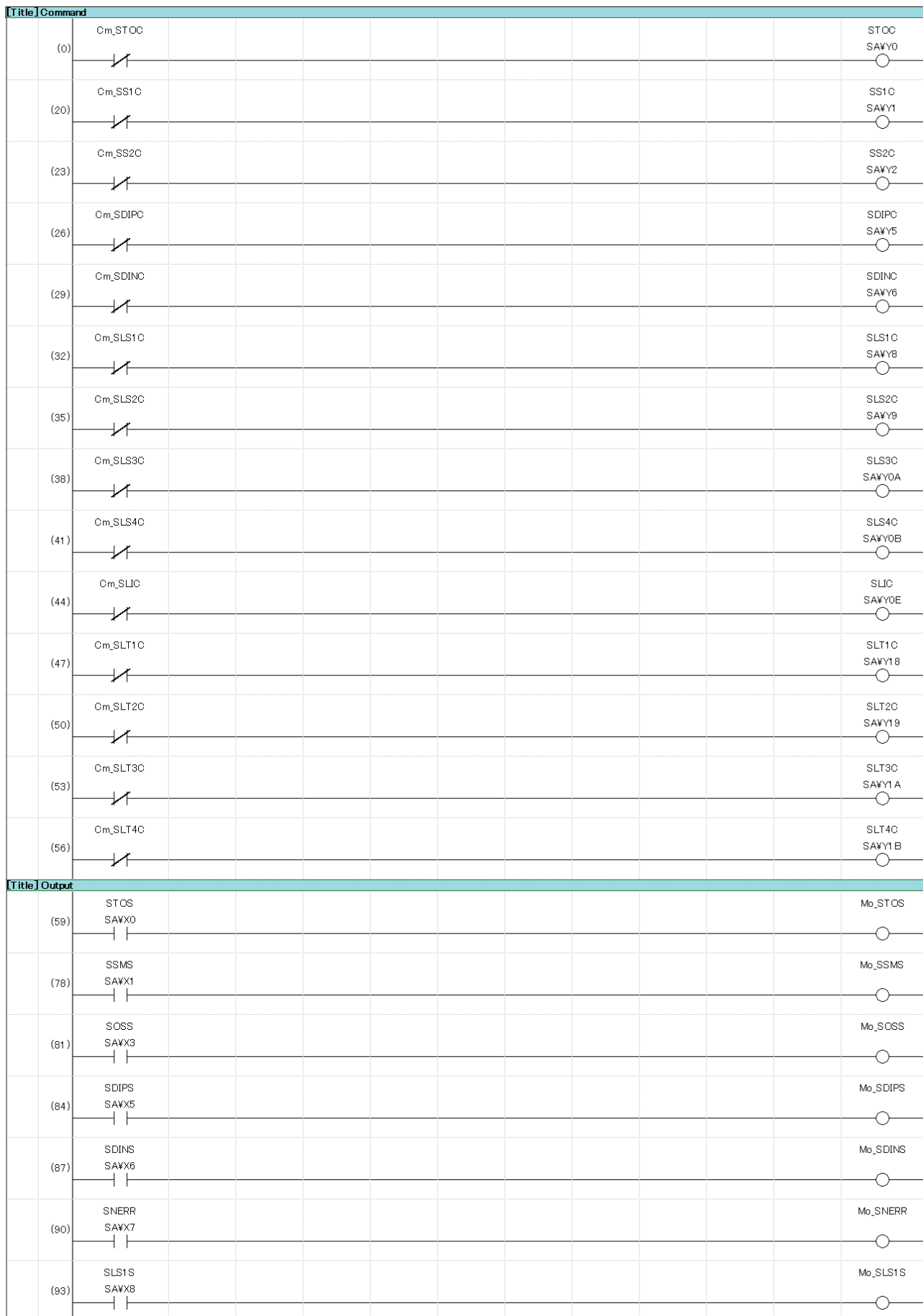



## Label used for drive control

	Label name	Data type	Class	Allocation (device/label)
1	AlwaysON	Bit	VAR_GLOBAL	SM400
2	RUN1ScanON	Bit	VAR_GLOBAL	SM402
3	RUN1ScanOFF	Bit	VAR_GLOBAL	SM403
4	Sequencer_Ready	Bit	VAR_GLOBAL	Y10
5	RD78_Ready	Bit	VAR_GLOBAL	X10
6	OP	Bit	VAR_GLOBAL	
7	OPF	Bit	VAR_GLOBAL	
8	OPR	Bit	VAR_GLOBAL	
9	SP_OVR	Double-precision real number	VAR_GLOBAL	
10	Err_OC	Bit	VAR_GLOBAL	

## Label used for FB

	Label name	Data type	Class	Allocation (device/label)
1	Axis0001	AXIS_REF	VAR_GLOBAL	<Detailed setting>
2	MC_Power_Ax	MC_Power	VAR_GLOBAL	
3	MC_MoveVl_Ax	MC_MoveVelocity	VAR_GLOBAL	
4	MC_SetOverride_Ax	MC_SetOverride	VAR_GLOBAL	
5	MC_Reset_Ax	MC_Reset	VAR_GLOBAL	
6	MCv_MotionErrReset	MCv_MotionErrorReset	VAR_GLOBAL	
7	Ib_Power_Ready	Bit	VAR_GLOBAL	
8	Ib_Power_ON	Bit	VAR_GLOBAL	
9	Ob_Power_Status	Bit	VAR_GLOBAL	
10	Ob_Power_ReadyStatus	Bit	VAR_GLOBAL	
11	Ob_Power_Busy	Bit	VAR_GLOBAL	
12	Ob_Power_Err	Bit	VAR_GLOBAL	
13	Ow_Power_ErrNo	Word [Unsigned]/Bit string [16-bit]	VAR_GLOBAL	
14	Ib_MovVl_Cmd	Bit	VAR_GLOBAL	
15	Ob_MovVl_Run	Bit	VAR_GLOBAL	
16	Ob_MovVl_Act	Bit	VAR_GLOBAL	
17	Ob_MovVl_CmdAb	Bit	VAR_GLOBAL	
18	Ob_MovVl_Done	Bit	VAR_GLOBAL	
19	Ob_MovVl_Err	Bit	VAR_GLOBAL	
20	Ow_MovVl_ErrNo	Word [Unsigned]/Bit string [16-bit]	VAR_GLOBAL	
21	Il_MovVl_Speed	Double-precision real number	VAR_GLOBAL	
22	Iw_MovVl_Dir	Word [Unsigned]/Bit string [16-bit] (0..15)	VAR_GLOBAL	
23	Ib_MovVl_ContiUp	Bit	VAR_GLOBAL	
24	Il_MovVl_Acce	Double-precision real number	VAR_GLOBAL	
25	Il_MovVl_Dece	Double-precision real number	VAR_GLOBAL	
26	Il_MovVl_Jerk	Double-precision real number	VAR_GLOBAL	
27	Iw_MovVl_BuffMod	Word [Signed]	VAR_GLOBAL	
28	Id_MovVl_Opt	Double word [Signed]	VAR_GLOBAL	
29	Ib_Ovr_Cmd	Bit	VAR_GLOBAL	
30	Il_Ovr_Val	Double-precision real number	VAR_GLOBAL	
31	Il_Ovr_Acce	Double-precision real number	VAR_GLOBAL	
32	Il_Ovr_Jerk	Double-precision real number	VAR_GLOBAL	
33	Ob_Ovr_Busy	Bit	VAR_GLOBAL	
34	Ob_Ovr_Act	Bit	VAR_GLOBAL	
35	Ob_Ovr_Err	Bit	VAR_GLOBAL	
36	Ob_Ovr_ErrNo	Word [Unsigned]/Bit string [16-bit]	VAR_GLOBAL	
37	Ib_ErrRst_Cmd	Bit	VAR_GLOBAL	

	Label name	Data type	Class	Allocation (device/label)
38	Id_ErrRst_Opt	Double word [Signed]	VAR_GLOBAL	
39	Ob_ErrRst_Done	Bit	VAR_GLOBAL	
40	Ob_ErrRst_Busy	Bit	VAR_GLOBAL	
41	Ob_ErrRst_ComAb	Bit	VAR_GLOBAL	
42	Ob_ErrRst_Err	Bit	VAR_GLOBAL	
43	Ob_ErrRst_ErrNo	Word [Unsigned]/Bit string [16-bit]	VAR_GLOBAL	
44	lb_ErrRst_Cmd_M	Bit	VAR_GLOBAL	
45	Id_ErrRst_Opt_M	Double word [Signed]	VAR_GLOBAL	
46	Ob_ErrRst_Done_M	Bit	VAR_GLOBAL	
47	Ob_ErrRst_Busy_M	Bit	VAR_GLOBAL	
48	Ob_ErrRst_ComAb_M	Bit	VAR_GLOBAL	
49	Ob_ErrRst_Err_M	Bit	VAR_GLOBAL	
50	Ob_ErrRst_ErrNo_M	Word [Unsigned]/Bit string [16-bit]	VAR_GLOBAL	

### Label used for safety control

	Label name	Data type	Class	Allocation (device/label)
1	STOC	Bit	VAR_GLOBAL	SA#Y0
2	SS1C	Bit	VAR_GLOBAL	SA#Y1
3	SS2C	Bit	VAR_GLOBAL	SA#Y2
4	SDIPC	Bit	VAR_GLOBAL	SA#Y5
5	SDINC	Bit	VAR_GLOBAL	SA#Y6
6	SLS1C	Bit	VAR_GLOBAL	SA#Y8
7	SLS2C	Bit	VAR_GLOBAL	SA#Y9
8	SLS3C	Bit	VAR_GLOBAL	SA#Y0A
9	SLS4C	Bit	VAR_GLOBAL	SA#Y0B
10	SLIC	Bit	VAR_GLOBAL	SA#Y0E
11	SLT1C	Bit	VAR_GLOBAL	SA#Y18
12	SLT2C	Bit	VAR_GLOBAL	SA#Y19
13	SLT3C	Bit	VAR_GLOBAL	SA#Y1A
14	SLT4C	Bit	VAR_GLOBAL	SA#Y1B
15	STOS	Bit	VAR_GLOBAL	SA#X0
16	SSMS	Bit	VAR_GLOBAL	SA#X1
17	SOSS	Bit	VAR_GLOBAL	SA#X3
18	SDIPS	Bit	VAR_GLOBAL	SA#X5
19	SDINS	Bit	VAR_GLOBAL	SA#X6
20	SNERR	Bit	VAR_GLOBAL	SA#X7
21	SLS1S	Bit	VAR_GLOBAL	SA#X8
22	SLS2S	Bit	VAR_GLOBAL	SA#X9
23	SLS3S	Bit	VAR_GLOBAL	SA#X0A
24	SLS4S	Bit	VAR_GLOBAL	SA#X0B
25	SS1S	Bit	VAR_GLOBAL	SA#X0C
26	SS2S	Bit	VAR_GLOBAL	SA#X0D
27	SLIS	Bit	VAR_GLOBAL	SA#X0E
28	SNERR2	Bit	VAR_GLOBAL	SA#X11
29	SBCS	Bit	VAR_GLOBAL	SA#X12
30	SLT1S	Bit	VAR_GLOBAL	SA#X18
31	SLT2S	Bit	VAR_GLOBAL	SA#X19
32	SLT3S	Bit	VAR_GLOBAL	SA#X1A
33	SLT4S	Bit	VAR_GLOBAL	SA#X1B
34	Emergency1	Bit	VAR_GLOBAL	SA#X40
35	Emergency2	Bit	VAR_GLOBAL	SA#X41

A

## Label used for drive control and safety control

	Label name	Data type	Class	Allocation (device/label)
1	Cm_STOC	Bit	VAR_GLOBAL	
2	Cm_SS1C	Bit	VAR_GLOBAL	
3	Cm_SS2C	Bit	VAR_GLOBAL	
4	Cm_SDIPC	Bit	VAR_GLOBAL	
5	Cm_SDINC	Bit	VAR_GLOBAL	
6	Cm_SLS1C	Bit	VAR_GLOBAL	
7	Cm_SLS2C	Bit	VAR_GLOBAL	
8	Cm_SLS3C	Bit	VAR_GLOBAL	
9	Cm_SLS4C	Bit	VAR_GLOBAL	
10	Cm_SLIC	Bit	VAR_GLOBAL	
11	Cm_SLT1C	Bit	VAR_GLOBAL	
12	Cm_SLT2C	Bit	VAR_GLOBAL	
13	Cm_SLT3C	Bit	VAR_GLOBAL	
14	Cm_SLT4C	Bit	VAR_GLOBAL	
15	Mo_STOS	Bit	VAR_GLOBAL	
16	Mo_SSMS	Bit	VAR_GLOBAL	
17	Mo_SOSS	Bit	VAR_GLOBAL	
18	Mo_SDIPS	Bit	VAR_GLOBAL	
19	Mo_SDINS	Bit	VAR_GLOBAL	
20	Mo_SNERR	Bit	VAR_GLOBAL	
21	Mo_SLS1S	Bit	VAR_GLOBAL	
22	Mo_SLS2S	Bit	VAR_GLOBAL	
23	Mo_SLS3S	Bit	VAR_GLOBAL	
24	Mo_SLS4S	Bit	VAR_GLOBAL	
25	Mo_SS1S	Bit	VAR_GLOBAL	
26	Mo_SS2S	Bit	VAR_GLOBAL	
27	Mo_SLIS	Bit	VAR_GLOBAL	
28	Mo_SNERR2	Bit	VAR_GLOBAL	
29	Mo_SBCS	Bit	VAR_GLOBAL	
30	Mo_SLT1S	Bit	VAR_GLOBAL	
31	Mo_SLT2S	Bit	VAR_GLOBAL	
32	Mo_SLT3S	Bit	VAR_GLOBAL	
33	Mo_SLT4S	Bit	VAR_GLOBAL	
34	EmergencyPB1	Bit	VAR_GLOBAL	
35	EmergencyPB2	Bit	VAR_GLOBAL	

# Appendix 3 Safety Remote Reset

Use SLMP to remotely reset the safety remote I/O module to clear the error and return to safety communication.

Remote resetting is effective:

- When resetting only the safety remote I/O module without turning off the entire system.
- As a countermeasure when an Ethernet cable or other such cable is disconnected.
- Recovering from safety communication failure caused by noise, etc.

**Point** 

Remote reset and safety communication recovery can be performed by simply using SLMP.

## Safety communication recovery procedure

This explains the procedure for recovering the safety communication of a safety remote I/O module.

A program is required for recovering safety communication.

For an example program, refer to “ Page 109 Program Example”.

The D LINK.LED and SAFETY.LED of the safety remote I/O module can be used to check whether safety communication is in progress.

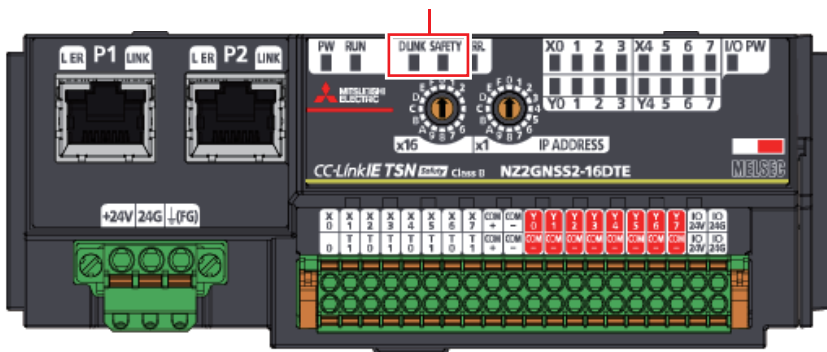

A

### 1. Safety communication error

When a safety communication error occurs, the D LINK.LED and SAFETY.LED of the safety remote I/O module turn off.



### 2. Determine the cause of the error.

Check the details, cause, and countermeasures for the error code (such as 1A40H), and then eliminate the primary cause of the error.

When the data link is restarted, the D LINK.LED of the safety remote I/O module lights. (The SAFETY.LED remains off.)



### 3. Check the interlock status of the safety station.

When the interlock is engaged, the bit (safety remote I/O module: station number 2) corresponding to the applicable safety connection for the safety interlock status of each safety connection turns on. (SA#SD1232.1 turns on.)

Device Name	F	E	D	C	B	A	9	8	7	6	5	4	3	2	1	0
SA#SD1230	0	0	0	0	0	0	0	0	0	0	0	0	0	0	0	0
SA#SD1231	0	0	0	0	0	0	0	0	0	0	0	0	0	0	0	0
SA#SD1232	0	0	0	0	0	0	0	0	0	0	0	0	0	0	1	0
SA#SD1233	0	0	0	0	0	0	0	0	0	0	0	0	0	0	0	0

**4.** Turn on device M1 to start the remote reset.

Use the JP.SLMPSND instruction to perform the remote reset.

Reset the safety remote I/O module (IP address: 192.168.3.2).

(Use devices D3 and D4 to set the IP address of the safety remote I/O module to reset.)

**5.** Disengage the safety station interlock.

To request the disengaging of the interlock, switch from off to on the applicable safety connection (safety remote I/O module: station number 2) for the safety interlock disengage request of each safety connection. (Switch SA#SD1240.1 from off to on.)

The safety station interlock is disengaged, recovering safety communication. (Switch SA#SD1232.1 from on to off.)

Device Name	F	E	D	C	B	A	9	8	7	6	5	4	3	2	1	0
SA#SD1230	0	0	0	0	0	0	0	0	0	0	0	0	0	0	0	0
SA#SD1231	0	0	0	0	0	0	0	0	0	0	0	0	0	0	0	0
SA#SD1232	0	0	0	0	0	0	0	0	0	0	0	0	0	0	0	0
SA#SD1233	0	0	0	0	0	0	0	0	0	0	0	0	0	0	0	0
SA#SD1234	0	0	0	0	0	0	0	0	0	0	0	0	0	0	0	0
SA#SD1235	0	0	0	0	0	0	0	0	0	0	0	0	0	0	0	0
SA#SD1236	0	0	0	0	0	0	0	0	0	0	0	0	0	0	0	0
SA#SD1237	0	0	0	0	0	0	0	0	0	0	0	0	0	0	0	0
SA#SD1238	0	0	0	0	0	0	0	0	0	0	0	0	0	0	0	0
SA#SD1239	0	0	0	0	0	0	0	0	0	0	0	0	0	0	0	0
SA#SD1240	0	0	0	0	0	0	0	0	0	0	0	0	0	0	1	0
SA#SD1241	0	0	0	0	0	0	0	0	0	0	0	0	0	0	0	0

The SAFETY.LED of the safety remote I/O module lights. (The D LINK.LED remains lit.)



**6.** Turn on device M2000 to clear the safety CPU module errors. The buffer memory of the safety module and the special registers for diagnostic information are cleared.

## Program Example

The following program performs a remote reset via SLMP.

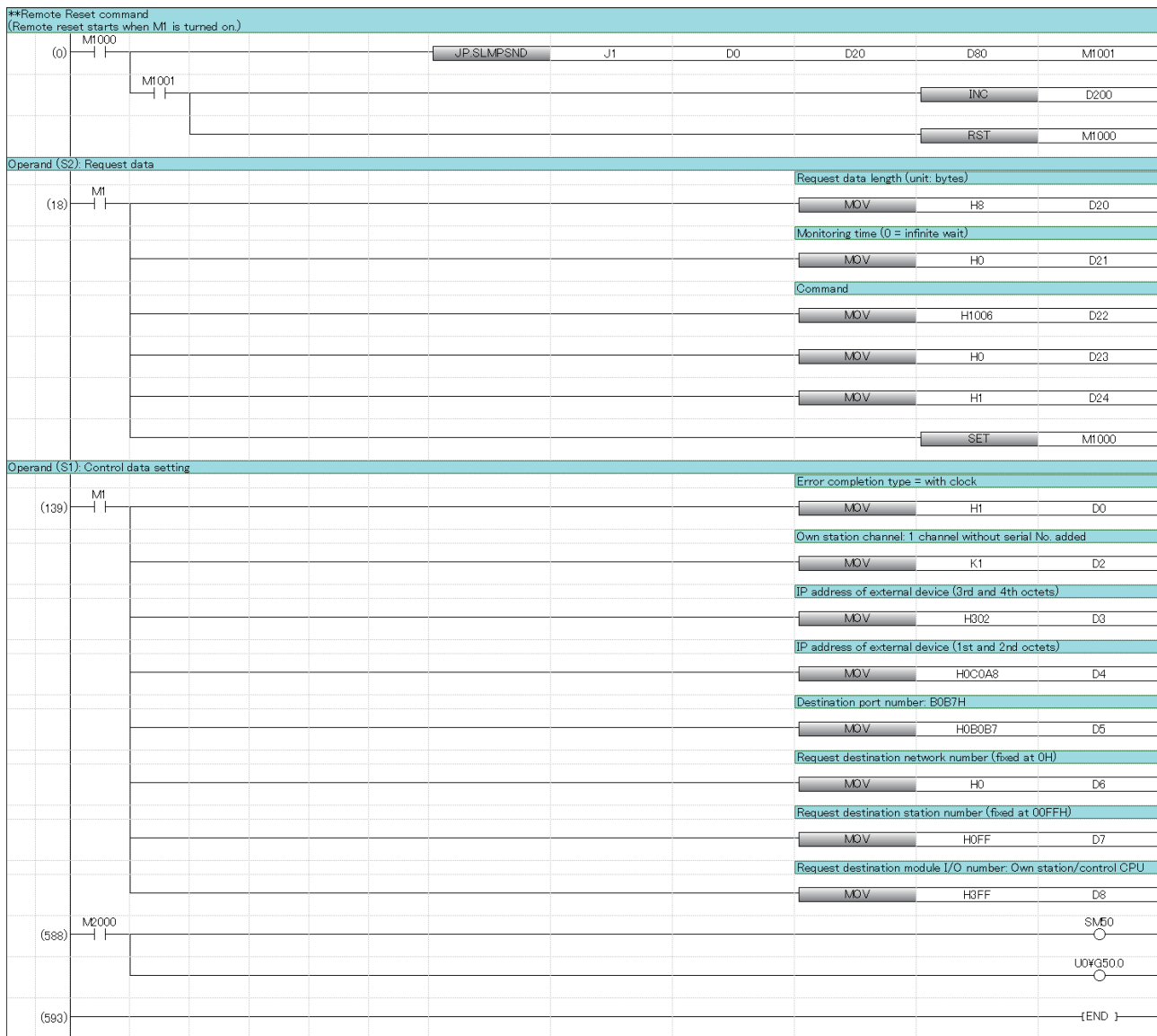

For details, refer to "5.12 Sending an SLMP Message" in the MELSEC iQ-R Programming Manual (Module Dedicated Instructions).

### Point

- Set the IP address of the device to be reset on devices D3 and D4.
- The above program can also be used with remote communication modules.

# MEMO

---

# REVISIONS

---

Revision date	Version	Description
April 2024	A	First edition
March 2025	B	■Additions and corrections PRODUCT APPLICATIONS, RELEVANT MANUALS, sections 2.6, 5.1, and Appendix 3

---

This document confers no industrial property rights or any rights of any other kind, nor does it confer any patent licenses. Mitsubishi Electric Corporation cannot be held responsible for any problems involving industrial property rights which may occur as a result of using the contents noted in this document.

---

© 2024 MITSUBISHI ELECTRIC CORPORATION

# TRADEMARKS

---

The company names, system names and product names mentioned in this document are either registered trademarks or trademarks of their respective companies.

In some cases, trademark symbols such as '™' or '®' are not specified in this document.



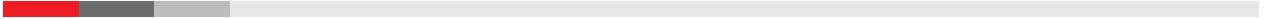

# **MITSUBISHI ELECTRIC CORPORATION**

HEAD OFFICE: TOKYO BLDG., 2-7-3, MARUNOUCHI, CHIYODA-KU, TOKYO 100-8310, JAPAN

[www.MitsubishiElectric.com](http://www.MitsubishiElectric.com)