



TECHNICAL BULLETIN

[1 / 42]

[Issue No.] GOT-A-0148-B

[Title] Precautions when Replacing GT11 Model with GT27 and GT25 Models for Overseas

[Date of Issue] First Edition: November 2019 (Ver. B: July 2021)

[Relevant Models] GOT1000 Series (GT11 Model) → GOT2000 Series (GT2705-VTBD, GT2505-VTBD, and GT2505HS-VTBD)

Thank you for your continued support of Mitsubishi Electric Graphic Operation Terminal (GOT). We released the GOT2000 series GT2705-VTBD in March 2015, GT2505-VTBD in August 2017, and GT2505HS-VTBD in March 2018 with high functions and performance as alternatives of the GT11 model. We highly recommend that you replace the GT11 model with GT2705-VTBD, GT2505-VTBD, or GT2505HS-VTBD for using new sophisticated features.

Contents

1. Recommended models for replacement.....	2
1.1 GOT.....	2
1.2 Communication unit.....	2
1.3 Option.....	3
1.4 Cable.....	3
1.4.1 RS-232 cable.....	3
1.4.2 RS-422 cable.....	3
1.4.3 External connection cable for Handy GOT.....	4
1.4.4 Q bus connection cable.....	4
1.4.5 Other cables.....	4
1.5 Software.....	5
1.6 Changing the connection type from the bus connection.....	5
1.6.1 Changing the connection type from the A bus connection.....	5
1.6.2 Changing the connection type from the Q bus connection.....	13
2. Comparison in specifications.....	19
2.1 Comparison in hardware specifications.....	19
2.1.1 Comparison in performance specifications between GT115□-Q□BD(□) and GT2705-VTBD, GT2505-VTBD.....	19
2.1.2 Comparison in power supply section specifications between GT115□-Q□BD(□) and GT2705-VTBD, GT2505-VTBD.....	23
2.1.3 Comparison in performance specifications between GT115□HS-Q□BD and GT2505HS-VTBD.....	24
2.1.4 Comparison in power supply section specifications between GT115□HS-Q□BD and GT2505HS-VTBD.....	25
2.2 Comparison in external dimensions.....	26
2.3 Comparison in panel cutting dimensions.....	29
2.4 Mounting intervals.....	30
2.4.1 When replacing GT11 models with GT2705-VTBD.....	30
2.4.2 When replacing GT11 models with GT2505-VTBD.....	31
2.5 Function specifications.....	32
2.5.1 Comparison in function specifications.....	32
2.5.2 Detailed comparison in function specifications.....	33
2.6 Screen design software specifications.....	37
2.6.1 Preparation before converting the project data.....	37
2.6.2 Procedure for converting the project data.....	37
2.6.3 Unsupported screen design function.....	39
2.6.4 Other major changes.....	39
REVISIONS.....	42

MITSUBISHI ELECTRIC CORPORATION

HEAD OFFICE : TOKYO BUILDING, 2-7-3 MARUNOUCHI, CHIYODA-KU, TOKYO 100-8310, JAPAN
NAGOYA WORKS : 1-14, YADA-MINAMI 5-CHOME, HIGASHI-KU, NAGOYA, JAPAN

1. Recommended models for replacement

Other models*1 can be selected depending on the usage conditions in your system. Select an appropriate model after checking the specifications of the current system.

For the specifications of GT2705-VTBD, GT2505-VTBD, and GT2505HS-VTBD, refer to the following.

→ GOT2000 Series User's Manual (Hardware) (SH-081194ENG)

- *1 Replacing with GT2105 is not recommended because it has many restrictions.
For the replacement with GT2105, contact your local sales office.

1.1 GOT

Table 1-1 List of replacement models from GT115□(HS) with GT2705, GT2505(HS)

○: Compatible, ×: Not compatible

GOT1000 series in use	Recommended GOT2000 series for replacement	Panel cut compatibility	Attachment necessity	Cable compatibility
GT1155-QTBD	GT2505-VTBD	○	Not necessary	○
GT1155-QSBD				
GT1155-QSBD-C				
GT1150-QLBD				
GT1150-QBBD-C				
GT1155-QTBDA	GT2505-VTBD *1*2			× *3
GT1155-QSBDA				
GT1150-QLBDA				
GT1155-QTBDQ	GT2705-VTBD *4			○
GT1155-QSBDQ	GT2505-VTBD *1*2			× *3
	GT2705-VTBD *4			○
GT1150-QLBDQ	GT2505-VTBD *1*2			× *3
	GT2705-VTBD *4			○
GT1155HS-QSBD	GT2505HS-VTBD *5	-	Not necessary	○
GT1150HS-QLBD				

- *1 Consider replacing with the communication type other than the bus connection.
→ 1.6 Changing the connection type from the bus connection
- *2 For GT2505-VTBD, a communication unit or option unit is not available.
To use a communication unit or option unit, consider replacing the GOT with the GT2705-VTBD.
- *3 The cable to be used depends on the communication type to be used.
→ 1.6 Changing the connection type from the bus connection
- *4 For the replacement with GT2705-VTBD, a Q bus connection communication unit (any one of GT15-QBUS, GT15-QBUS2, GT15-75QBUSL, or GT15-75QBUS2L) is necessary.
- *5 The cable connector for PLC communication of GT2505HS-VTBD is set to the "Ethernet" connection at factory default.
To perform the serial connection with a peripheral such as a PLC, set the cable connector for PLC communication to "RS-232" or "RS-422".
The cable connector for PLC communication is inside of the environmental protection back cover.
→ GOT2000 Series Handy GOT Connection Manual For GT Works3 Version1 (SH-081867ENG)

1.2 Communication unit

The communication units for the GOT1000 series can be used with the GOT2000 series as-is.

Check the availability in the following table.

Table 1-2 List of replacement models for communication units

○: Available as-is, ×: Not available

Unit for GOT1000		Availability	Remarks
Product name	Model		
Serial multi-drop	GT01-RS4-M	○	For the GOT multi-drop connection
Connection conversion adapter	GT10-9PT5S	○	Conversion connector between D-sub 9-pin (male) and European terminal block 5-pin
CC-Link interface unit	GT11HS-CCL	○	CC-Link interface unit for Handy GOT
	GT11H-CCL		

1.3 Option

For options, use the products for the GOT2000 series.

Some options can be used as-is.

Check the availability in the following table.

Table 1-3 List of replacement models for options

○: Available as-is, ×: Not available

Product name	Availability	Remarks
Option function board	×	Products for the GOT1000 series cannot be used. No option function board is necessary for the GOT2000 series.
Protective sheet	×	Products for the GOT1000 series cannot be used. Use the products for the GOT2000 series. (Models of the protective sheet for GT2705-VTBD: GT25-05PSGC, GT25-05PSCC Models of the protective sheet for GT2505-VTBD: GT25-05PSGC-2, GT25-05PSCC-2) * Because the design of the front face panel and the position of the USB port differ.
Protective sheet (for Handy GOT)	×	Products for the GOT1000 series (for GT11 Handy) cannot be used. Use the products for the GOT2000 series. (Model: GT14H-50PSC)
USB environmental protection cover	×	Products for the GOT1000 series cannot be used. Use the products for the GOT2000 series. (Model of the USB environmental protection cover for GT2705-VTBD: GT25-05UCOV Model of the USB environmental protection cover for GT2505-VTBD: GT21-WUCOV)
Protective cover for oil	×	Products for the GOT1000 series cannot be used. Use the products for the GOT2000 series. (Model of the protective cover for oil for GT2705-VTBD: GT25-05PCO Model of the protective cover for oil for GT2505-VTBD: GT25-05PCO-2)
Stand	○	Products for the GOT1000 series can be used as-is.
Memory card (CF card)	×	Products for the GOT1000 series cannot be used. Use the products (SD cards) for the GOT2000 series.
Attachment	○	The attachment used in the GOT1000 series can be used as-is. * At the replacement of the GOT1000 series with the GOT2000 series, no attachment is necessary because the panel cutting dimensions are the same.
Battery (spare)	○	Products for the GOT1000 series can be used as-is. * GT2705-VTBD, GT2505-VTBD, and GT2505HS-VTBD have a built-in battery at factory default.
Emergency stop switch guard cover	×	Products for the GOT1000 series (for GT11 Handy) cannot be used. Use the products for the GOT2000 series. (Model: GT14H-50ESCOV)
Connector conversion box	○	Products for the GOT1000 series can be used as-is. (Model: GT11H-CNB-37S)

1.4 Cable

1.4.1 RS-232 cable

The currently used cable for the GOT1000 series (including the cable for Handy GOT) can be used as-is for the GOT2000 series.

For the following cable for Handy GOT, use the one with version C or later.

- GT11H-C15R2-6P

1.4.2 RS-422 cable

The currently used cable for the GOT1000 series (including the cable for Handy GOT) can be used as-is for the GOT2000 series.

For the following cable for Handy GOT, use the one with version C or later.

- GT11H-C15R4-8P
- GT11H-C15R4-25P

[Issue No.] GOT-A-0148-B

1.4.3 External connection cable for Handy GOT

For the following cables among the currently used external connection cables for Handy GOT, use the ones with version C or later.

- GT11H-C30-37P
- GT11H-C60-37P
- GT11H-C100-37P
- GT11H-C30
- GT11H-C60
- GT11H-C100

1.4.4 Q bus connection cable**(1) Utilization of currently used cables**

The currently used Q bus connection cable for the GOT1000 series can be used as-is for the GOT2000 series.

(2) Replacement of GOT when multiple units are connected by Q bus connection

When multiple GOT1000 series GOTs are connected by the Q bus connection, one or more of the units can be replaced with the GOT2000 series. In this case, the GOT1000 series and GOT2000 series can coexist.

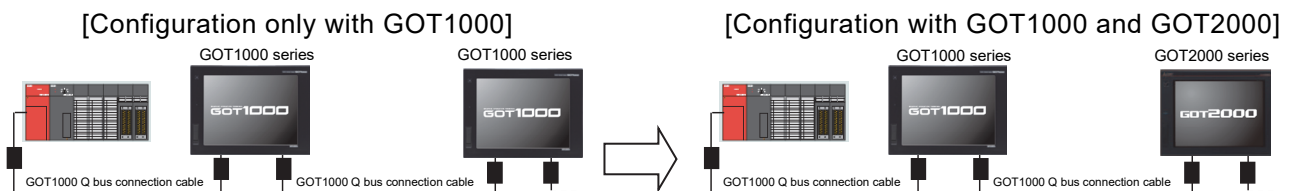

* When multiple GOTs are connected by the Q bus connection, GT11 can be used at the terminal only.

1.4.5 Other cables

The currently used cables for the GOT1000 series (including the cable for Handy GOT) other than the above can be used as-is for the GOT2000 series.

1.5 Software

To create the project data, MELSOFT GT Designer3 (GOT2000) is necessary. The supported version of MELSOFT GT Designer3 (GOT2000) differs depending on the model. For the supported version and how to obtain, refer to Table 1-5.

Table 1-5 Supported software version and how to obtain

Software	Supported version	How to obtain
GOT screen design software MELSOFT GT Works3	<ul style="list-style-type: none"> ■Japanese/English/Chinese version MELSOFT GT Designer3 (GOT2000) enclosed with MELSOFT GT Works3 Version1.130L or later for creating the project data of GT2705-VTBD. MELSOFT GT Designer3 (GOT2000) enclosed with MELSOFT GT Works3 Version1.180N or later for creating the project data of GT2505-VTBD. MELSOFT GT Designer3 (GOT2000) enclosed with MELSOFT GT Works3 Version1.195D or later for creating the project data of GT2505HS-VTBD. 	The versions shown on the left are supported. If your version is old, contact your local sales office for how to obtain the latest version.
GOT screen design software MELSOFT GT Works2 MELSOFT GT Designer2	Not supported	To create the project data for GOT2000, purchase MELSOFT GT Works3.
FA integrated engineering software MELSOFT iQ Works	<ul style="list-style-type: none"> ■Japanese/English version Ver.2.11M or later for creating the project data of GT2705-VTBD. *1 Ver.2.48Q or later for creating the project data of GT2505-VTBD. *2 Ver.2.50C or later for creating the project data of GT2505HS-VTBD. *3 	The versions shown on the left are supported. If your version is old, contact your local sales office for how to obtain the latest version.

*1 To use the interaction function of MELSOFT Navigator and MELSOFT GT Works3, update MELSOFT GT Works3 to Version1.136S or later.
 *2 To use the interaction function of MELSOFT Navigator and MELSOFT GT Works3, update MELSOFT GT Works3 to Version1.185T or later.
 *3 To use the interaction function of MELSOFT Navigator and MELSOFT GT Works3, update MELSOFT GT Works3 to Version1.197F or later.

1.6 Changing the connection type from the bus connection

1.6.1 Changing the connection type from the A bus connection

The A bus connection unit for the GOT2000 series has been discontinued since the end of January in 2015.

When the A bus connection is used with the GT11 model, change the communication type or replace the PLC.

To replace the PLC, refer to the following Technical Bulletin.

- Production discontinuation of MELSEC-AnS/QnAS (small type) series and MELSEC-I/OLINK (FA-A-0142)
- Production discontinuation of MELSEC-A/QnA (large type) series (T99-0050)

When changing the communication type from the A bus connection, refer to the following.

- ■1. Setting of PLC and GOT
- 2. Communication type

■1. Setting of PLC and GOT

When changing the communication type, check the settings of the PLC and GOT.

(1) PLC

When the GOT in the bus connection is removed or communication units are added to the PLC, the setting of the PLC may need to be changed.

Change the parameter setting (such as I/O assignment), the I/O number in the sequence program, and others according to the configuration of the PLC.

[Issue No.] GOT-A-0148-B

(2) GOT

Change the controller setting. *1

When changing to the network connection (other than the Ethernet connection), set the network number and station number to the device number of each object. *2

*1 Setting example of the controller

When connecting to the MELSEC-A series using the direct CPU connection (serial)

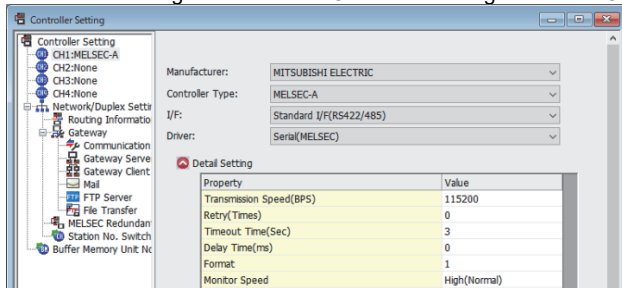

*2 Setting of the network No. and station No.

When monitoring D0 of the CPU with network No. 1 and station No. 2

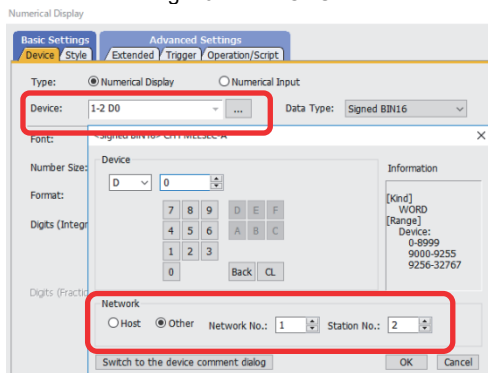

■2. Communication type

(1) Replacing with the serial connection

(a) Direct CPU connection (serial)

Configure the connection as follows.

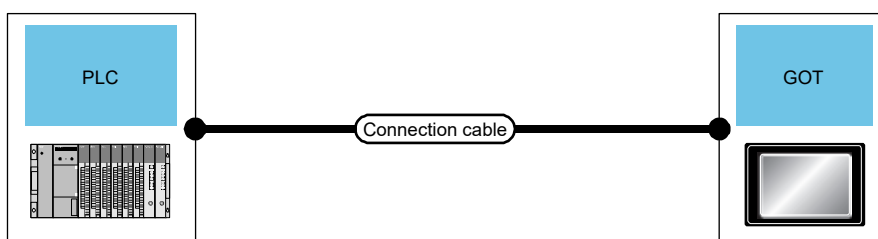

1) Connecting to MELSEC-A (ACPU, AnCPU, AnSCPU) or MELSEC-QnA (QnACPU, QnASCPU)

PLC		Connection cable *1	GOT	
CPU module	Communication type		Option	GOT
MELSEC-A (ACPU)	RS-422	GT01-C30R4-25P (3 m) GT01-C100R4-25P (10 m) GT01-C200R4-25P (20 m) GT01-C300R4-25P (30 m)	(Built in the GOT)	GT2705-VTBD GT2505-VTBD
MELSEC-A (AnCPU)			GT15-RS4-9S	GT2705-VTBD
MELSEC-A (AnSCPU)				
MELSEC-Q (QnACPU)				
MELSEC-Q (QnASCPU)				

*1 When the distance between the connected devices exceeds 30 m, consider replacing with the network connection.

[Issue No.] GOT-A-0148-B

(b) Computer link connection

Configure the connection as follows.

When replacing with the computer link connection, a computer link module is required on the PLC.

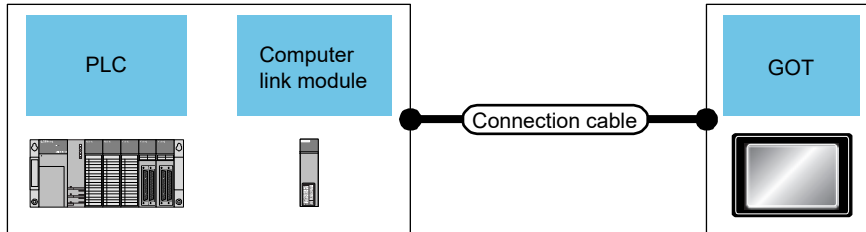

1) Connecting to MELSEC-A (ACPU, AnCPU)

PLC		Connection cable *1*2	GOT	
Computer link module	Communication type		Option	GOT
AJ71UC24 *3	RS-232	GT09-C30R2-25P (3 m) User-created cable (15 m max.)	(Built in the GOT) GT15-RS2-9P	GT2705-VTBD GT2505-VTBD GT2705-VTBD
	RS-422	GT09-C30R4-6C (3 m) GT09-C100R4-6C (10 m) GT09-C200R4-6C (20 m) GT09-C300R4-6C (30 m) User-created cable (500 m max.)	(Built in the GOT) GT15-RS4-9S	GT2705-VTBD GT2505-VTBD GT2705-VTBD

*1 For the user-created cable, refer to the following.

→ GOT2000 Series Connection Manual (Mitsubishi Electric Products) For GT Works3 Version1 (SH-081197ENG)

*2 When the distance between the connected devices exceeds 30 m, consider replacing with the connection with user-created cables or the network connection.

*3 This module has been discontinued.

2) Connecting to MELSEC-A (AnSCPU, AOJ2HCPU, A2CCPU)

PLC		Connection cable *1*2	GOT	
Computer link module	Communication type		Option	GOT
A1SJ71UC24-R2 *3 A1SJ71C24-R2 *3 A1SJ71UC24-PRF *3 A1SJ71C24-PRF *3	RS-232	GT09-C30R2-9P (3 m) User-created cable (15 m max.)	(Built in the GOT) GT15-RS2-9P	GT2705-VTBD GT2505-VTBD GT2705-VTBD
			(Built in the GOT) GT15-RS4-9S	GT2705-VTBD GT2505-VTBD GT2705-VTBD
A1SJ71UC24-R4 *3 A1SJ71C24-R4 *3	RS-422	GT09-C30R4-6C (3 m) GT09-C100R4-6C (10 m) GT09-C200R4-6C (20 m) GT09-C300R4-6C (30 m) User-created cable (500 m max.)	(Built in the GOT) GT15-RS4-9S	GT2705-VTBD GT2505-VTBD GT2705-VTBD
			(Built in the GOT)	GT2705-VTBD

*1 For the user-created cable, refer to the following.

→ GOT2000 Series Connection Manual (Mitsubishi Electric Products) For GT Works3 Version1 (SH-081197ENG)

*2 When the distance between the connected devices exceeds 30 m, consider replacing with the connection with user-created cables or the network connection.

*3 This module has been discontinued.

[Issue No.] GOT-A-0148-B

3) Connecting to MELSEC-QnA (QnACPU)

PLC		Connection cable *1*2	GOT	
Serial communication/computer link module	Communication type		Option	GOT
AJ71QC24 *4 AJ71QC24N *4 AJ71QC24-R2 *4 AJ71QC24N-R2 *4	RS-232	GT09-C30R2-25P (3 m) User-created cable (15 m max.)	(Built in the GOT)	GT2705-VTBD GT2505-VTBD
			GT15-RS2-9P	GT2705-VTBD
AJ71QC24-R4 *4 AJ71QC24N-R4 *4	RS-422	GT01-C30R4-25P (3 m) GT01-C100R4-25P (10 m) GT01-C200R4-25P (20 m) GT01-C300R4-25P (30 m)	(Built in the GOT)	GT2705-VTBD GT2505-VTBD
			GT15-RS4-9S	GT2705-VTBD
AJ71QC24 *4 AJ71QC24N *4 AJ71QC24-R4 *4 AJ71QC24N-R4 *4	RS-422	GT09-C30R4-6C (3 m) GT09-C100R4-6C (10 m) GT09-C200R4-6C (20 m) GT09-C300R4-6C (30 m) User-created cable (1200 m max.)	(Built in the GOT)	GT2705-VTBD GT2505-VTBD
			GT15-RS4-9S	GT2705-VTBD
AJ71UC24 *3*4	RS-232	GT09-C30R2-25P (3 m) User-created cable (15 m max.)	(Built in the GOT)	GT2705-VTBD GT2505-VTBD
			GT15-RS2-9P	GT2705-VTBD
AJ71UC24 *3*4	RS-422	GT09-C30R4-6C (3 m) GT09-C100R4-6C (10 m) GT09-C200R4-6C (20 m) GT09-C300R4-6C (30 m) User-created cable (500 m max.)	(Built in the GOT)	GT2705-VTBD GT2505-VTBD
			GT15-RS4-9S	GT2705-VTBD

- *1 For the user-created cable, refer to the following.
→ GOT2000 Series Connection Manual (Mitsubishi Electric Products) For GT Works3 Version1 (SH-081197ENG)
- *2 When the distance between the connected devices exceeds 30 m, consider replacing with the connection with user-created cables or the network connection.
- *3 The range of available device numbers is the device range of AnACPU.
- *4 This module has been discontinued.

4) Connecting to MELSEC-QnA (QnASCPU)

PLC		Connection cable *1*2	GOT	
Serial communication/computer link module	Communication type		Option	GOT
A1SJ71QC24 *4 A1SJ71QC24N *4 A1SJ71QC24N1 *4 A1SJ71QC24-R2 *4 A1SJ71QC24N-R2 *4 A1SJ71QC24N1-R2 *4	RS-232	GT09-C30R2-9P (3 m) User-created cable (15 m max.)	(Built in the GOT)	GT2705-VTBD GT2505-VTBD
			GT15-RS2-9P	GT2705-VTBD
A1SJ71QC24 *4 A1SJ71QC24N *4 A1SJ71QC24N1 *4	RS-422	GT09-C30R4-6C (3 m) GT09-C100R4-6C (10 m) GT09-C200R4-6C (20 m) GT09-C300R4-6C (30 m) User-created cable (1200 m max.)	(Built in the GOT)	GT2705-VTBD GT2505-VTBD
			GT15-RS4-9S	GT2705-VTBD
A1SJ71UC24-R2 *3*4 A1SJ71C24-R2 *3*4 A1SJ71UC24-PRF *3*4 A1SJ71C24-PRF *3*4	RS-232	GT09-C30R2-9P (3 m) User-created cable (15 m max.)	(Built in the GOT)	GT2705-VTBD GT2505-VTBD
			GT15-RS2-9P	GT2705-VTBD
A1SJ71UC24-R4 *3*4 A1SJ71C24-R4 *3*4	RS-422	GT09-C30R4-6C (3 m) GT09-C100R4-6C (10 m) GT09-C200R4-6C (20 m) GT09-C300R4-6C (30 m) User-created cable (15 m max.)	(Built in the GOT)	GT2705-VTBD GT2505-VTBD
			GT15-RS4-9S	GT2705-VTBD

- *1 For the user-created cable, refer to the following.
→ GOT2000 Series Connection Manual (Mitsubishi Electric Products) For GT Works3 Version1 (SH-081197ENG)
- *2 When the distance between the connected devices exceeds 30 m, consider replacing with the connection with user-created cables or the network connection.
- *3 The range of available device numbers is the device range of AnACPU.
- *4 This module has been discontinued.

(2) Replacing with the network connection

(a) Ethernet connection

Configure the connection as follows.

When replacing with the Ethernet connection, an Ethernet module is required on the PLC.

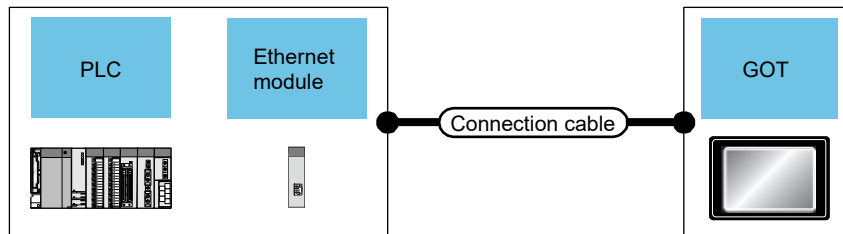

1) Connecting to MELSEC-A (AnCPU, AnSCPU)

PLC		Connection cable	GOT	
Ethernet module	Communication type		Option	GOT
AJ71E71N3-T *1*2	Ethernet	Twisted cable - 10BASE-T - 100BASE-TX	(Built in the GOT)	GT2705-VTBD GT2505-VTBD
AJ71E71N-B5 *1*2				
AJ71E71N-B2 *1*2				
AJ71E71N-T *1*2				
AJ71E71N-B5T *1*2				
AJ71E71-S3 *1*2				
A1SJ71E71N3-T *1*2				
A1SJ71E71N-B5 *1*2				
A1SJ71E71N-B2 *1*2				
A1SJ71E71N-T *1*2				
A1SJ71E71N-B5T *1*2				
A1SJ71E71-B5-S3 *1*2				
A1SJ71E71-B2-S3 *1*2				

*1 This module has been discontinued.

*2 The applicable destination to connect the twisted pair cable depends on the configuration of the Ethernet network system to be used.

Connect to the Ethernet module, hub, transceiver, wireless LAN adapter (NZ2WL-JPA or NZ2WL-JPS), or other system equipment according to the Ethernet network system to be used.

Use the cable, connector, or hub that meets the IEEE802.3 10BASE-T/100BASE-TX standards.

To connect to the Ethernet module, a cross cable can be used.

For the controller to which the wireless LAN adapter can be connected and how to configure the settings for the wireless LAN adapter, refer to the manual of the wireless LAN adapter to be used.

[Issue No.] GOT-A-0148-B

2) Connecting to MELSEC-QnA (QnACPU, QnASCPU)

PLC		Connection cable	GOT	
Ethernet module	Communication type		Option	GOT
AJ71QE71N3-T *1 AJ71QE71N-B5 *1 AJ71QE71N-B2 *1 AJ71QE71N-T *1 AJ71QE71N-B5T *1 AJ71QE71 *1 AJ71QE71-B5 *1 A1SJ71QE71N3-T *1 A1SJ71QE71N-B5 *1 A1SJ71QE71N-B2 *1 A1SJ71QE71N-T *1 A1SJ71QE71N-B5T *1 A1SJ71QE71-B5 *1 A1SJ71QE71-B2 *1	Ethernet	Twisted cable - 10BASE-T - 100BASE-TX	(Built in the GOT)	GT2705-VTBD GT2505-VTBD

*1 This module has been discontinued.

*2 The applicable destination to connect the twisted pair cable depends on the configuration of the Ethernet network system to be used.
Connect to the Ethernet module, hub, transceiver, wireless LAN adapter (NZ2WL-JPA or NZ2WL-JPS), or other system equipment according to the Ethernet network system to be used.
Use the cable, connector, or hub that meets the IEEE802.3 10BASE-T/100BASE-TX standards.
To connect to the Ethernet module, a cross cable can be used.
For the controller to which the wireless LAN adapter can be connected and how to configure the settings for the wireless LAN adapter, refer to the manual of the wireless LAN adapter to be used.

(b) CC-Link connection (Intelligent device station)

Configure the connection as follows.

When replacing with the CC-Link (intelligent device station) connection, a CC-Link module is required on the PLC.

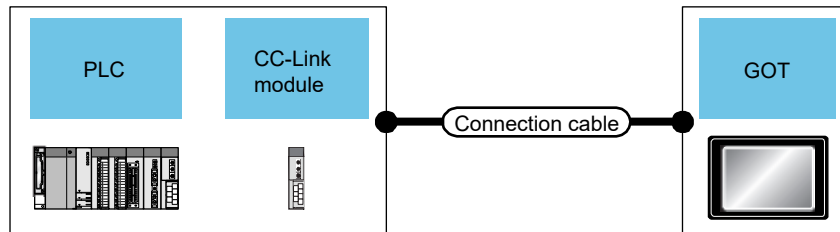

1) Connecting to MELSEC-A (ACPU *1, AnCPU, AnSCPU)

PLC		Connection cable	GOT	
CC-Link module	Communication type		Option	GOT
AJ61BT11 *3 A1SJ61BT11	CC-Link (Ver.1)	CC-Link dedicated cable	GT15-J61BT13 *2	GT2705-VTBD

*1 Only A0J2HCPU, A0J2HCPUP21, A0J2HCPUR21, and A0J2HCPU-DC24 can be connected.

*2 In the controller setting, set the mode to Ver.1.

*3 This module has been discontinued.

2) Connecting to MELSEC-QnA (QnACPU, QnASCPU)

PLC		Connection cable	GOT	
CC-Link module	Communication type		Option	GOT
AJ61QBT11 *2 A1SJ61QBT11	CC-Link (Ver.1)	CC-Link dedicated cable	GT15-J61BT13 *1	GT2705-VTBD

*1 In the controller setting, set the mode to Ver.1.

*2 This module has been discontinued.

[Issue No.] GOT-A-0148-B

(c) MELSECNET/10 connection

Configure the connection as follows.

When replacing with the MELSECNET/10 connection, a MELSECNET/10 module is required on the PLC. On the GOT, a MELSECNET/H communication module (used in the MNET/10 mode) is required.

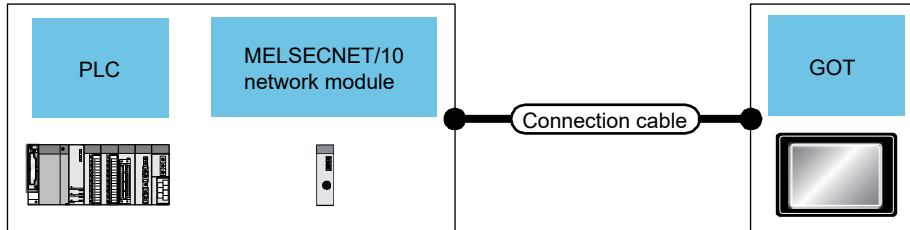

1) Connecting to MELSEC-A (AnCPU *1, AnSCPU *1) (optical loop system)

PLC		Connection cable	GOT	
MELSECNET/10 module	Communication type		Option	GOT
AJ71LP21 *3 A1SJ71LP21 *3	MELSECNET/10	Fiber-optic cable	GT15-J71LP23-25 *2	GT2705-VTBD

*1 A2UCPU, A2UCPU-S1, A3UCPU, A4UCPU, A2USCPU, A2USCPU-S1, and A2USHCPU-S1 can be connected.

*2 In the controller setting, set the MNET/10 mode.

*3 This module has been discontinued.

2) Connecting to MELSEC-QnA (QnACPU, QnASCPU) (optical loop system)

PLC		Connection cable	GOT	
MELSECNET/10 module	Communication type		Option	GOT
AJ71QLP21 *2 AJ71QLP21S *2 A1SJ71QLP21 *2 A1SJ71QLP21S *2	MELSECNET/10	Fiber-optic cable	GT15-J71LP23-25 *1	GT2705-VTBD

*1 In the controller setting, set the MNET/10 mode.

*2 This module has been discontinued.

3) Connecting to MELSEC-A (AnCPU *1, AnSCPU *1) (coaxial bus system)

PLC		Connection cable	GOT	
MELSECNET/10 module	Communication type		Option	GOT
AJ71BR11 *3 A1SJ71BR11 *3	MELSECNET/10	Coaxial cable	GT15-J71BR13 *2	GT2705-VTBD

*1 A2UCPU, A2UCPU-S1, A3UCPU, A4UCPU, A2USCPU, A2USCPU-S1, and A2USHCPU-S1 can be connected.

*2 In the controller setting, set the MNET/10 mode.

*3 This module has been discontinued.

4) Connecting to MELSEC-QnA (QnACPU, QnASCPU) (coaxial bus system)

PLC		Connection cable	GOT	
MELSECNET/10 module	Communication type		Option	GOT
AJ71QBR11 *2 A1SJ71QBR11 *2	MELSECNET/10	Coaxial cable	GT15-J71BR13 *1	GT2705-VTBD

*1 In the controller setting, set the MNET/10 mode.

*2 This module has been discontinued.

[Issue No.] GOT-A-0148-B

(3) Replacement when multiple units are connected

Consider the following connection types for the replacement of the configuration in which multiple units are connected.

- Network connection
 - 1.6.1 ■2. (2) Replacing with the network connection
- Multi-drop connection
 - (a) Multi-drop connection

(a) Multi-drop connection *1

Configure the connection as follows.

When replacing with the multi-drop connection, the following options and cables are required.

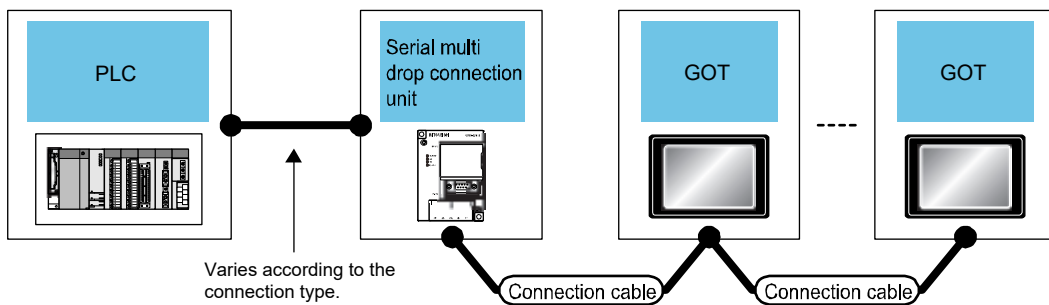

*1 If the number of connected slave GOTs or the number of devices of each GOT increase, the device update cycle on the screen may be delayed.
 In this case, it is recommended to reduce the number of devices of each GOT.
 (The standard number of devices is 250 per GOT, and 750 in total.)
 If a timeout error occurs, extend the timeout time with the controller setting of the slave GOT.

1) Connecting to MELSEC-A (ACPU, AnCPU, AnSCPU) *1*2, MELSEC-QnA (QnACPU *3, QnASCPU) *4

For the system configuration between the serial multi-drop connection unit and the PLC, refer to each connection type.

Multi-drop connection unit		Cable *5	GOT	
Serial multi-drop connection unit	Communication type		Option	GOT
GT01-RS4-M	RS-485	User-created cable (500 m max. *6)	(Built in the GOT)	GT2705-VTBD GT2505-VTBD
			GT15-RS4-9S	GT2705-VTBD
			GT15-RS4-TE	GT2705-VTBD

*1 Cannot be connected when the PLC and serial multi-drop connection unit are connected by the computer link connection.
 *2 The SB, SW, Ww, Wr, ER, and BM devices cannot be monitored.
 *3 Q4ARCPU cannot be connected.
 *4 The Ww and Wr devices cannot be monitored.
 *5 For the user-created cable, refer to the following.
 → GOT2000 Series Connection Manual (Mitsubishi Electric Products) For GT Works3 Version1 (SH-081197ENG)
 *6 This is the maximum distance between the PLC and the GOT (terminal).

[Issue No.] GOT-A-0148-B

1.6.2 Changing the connection type from the Q bus connection

When changing the communication type from the Q bus connection, refer to the following.

- ■1. Setting of PLC and GOT
- 2. Communication type

■1. Setting of PLC and GOT

When changing the communication type, check the settings of the PLC and GOT.

(1) PLC

When the GOT in the bus connection is removed or communication units are added to the PLC, the setting of the PLC may need to be changed. Change the parameter setting (such as I/O assignment), the I/O number in the sequence program, and others according to the configuration of the PLC.

(2) GOT

Change the controller setting. *1

When changing to the network connection (other than the Ethernet connection), set the network number and station number to the device number of each object. *2

*1 Example of the controller setting

When connecting to the MELSEC-Q series using the direct CPU connection (serial)

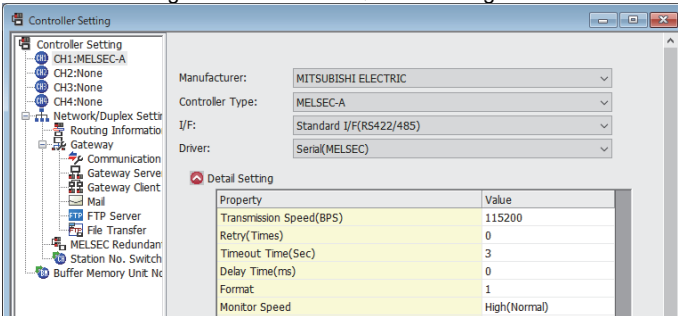

*2 Setting of the network No. and station No.

When monitoring D0 of the CPU with network No. 1 and station No. 2

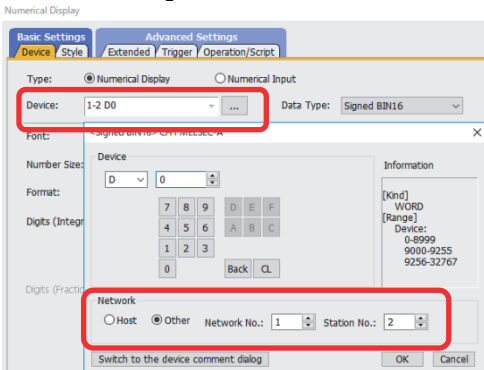

[Issue No.] GOT-A-0148-B

■2. Communication type

(1) Replacing with the serial connection

(a) Direct CPU connection (serial)

Configure the connection as follows.

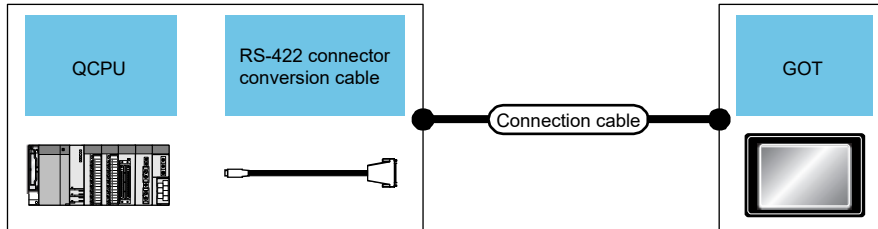

PLC			Connection cable *1	GOT	
CPU module	RS-422 conversion cable	Communication type		Option	GOT
MELSEC-Q (Q mode) MELSEC-Q (A mode) C Controller module (Q Series)	-	RS-232	GT01-C30R2-6P (3 m)	(Built in the GOT)	GT2705-VTBD GT2505-VTBD
	FA-CNV2402CBL (0.2m) FA-CNV2405CBL (0.5m)	RS-422	GT01-C30R4-25P (3 m) GT01-C100R4-25P (10 m) GT01-C200R4-25P (20 m) GT01-C300R4-25P (30 m)	(Built in the GOT) GT15-RS4-9S	GT2705-VTBD GT2505-VTBD GT2705-VTBD

*1 When the distance between the connected devices exceeds 30 m, consider replacing with the network connection.

(b) Serial communication connection

Configure the connection as follows.

When replacing with the serial communication connection, a serial communication connection module is required on the PLC.

Connecting to MELSEC-Q (Q mode)

PLC		Connection cable *1	GOT	
Computer link module	Communication type		Option	GOT
QJ71C24 *2 QJ71C24N QJ71C24-R2 *2 QJ71C24N-R2 QJ71CMO *2 QJ71CMON *2	RS-232	GT09-C30R2-9P (3 m) User-created cable (15 m max.)	(Built in the GOT)	GT2705-VTBD GT2505-VTBD
			GT15-RS2-9P	GT2705-VTBD
QJ71C24 *2 QJ71C24N QJ71C24N-R4	RS-422	GT09-C30R4-6C (3 m) GT09-C100R4-6C (10 m) GT09-C200R4-6C (20 m) GT09-C300R4-6C (30 m) User-created cable (500 m max.)	(Built in the GOT)	GT2705-VTBD GT2505-VTBD
			GT15-RS4-9S	GT2705-VTBD

*1 For the user-created cable, refer to the following.

→ GOT2000 Series Connection Manual (Mitsubishi Electric Products) For GT Works3 Version1 (SH-081197ENG)

*2 This module has been discontinued.

(2) Replacing with the network connection

(a) MELSECNET/10 connection

Configure the connection as follows.

When replacing with the MELSECNET/10 connection, a MELSECNET/10 module is required on the PLC. On the GOT, a MELSECNET/H communication module (used in the MNET/10 mode) is required.

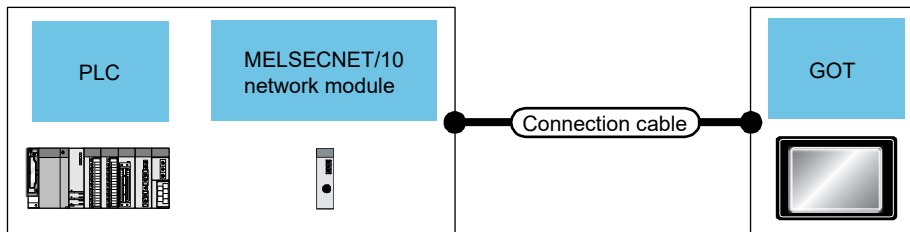

1) Connecting to MELSEC-Q (optical loop system)

PLC		Connection cable	GOT	
MELSECNET/H module	Communication type		Option	GOT
QJ71LP21 *2 QJ71LP21-25 QJ71LP21S-25	MELSECNET/10	Fiber-optic cable	GT15-J71LP23-25 *1	GT2705-VTBD

*1 In the controller setting, set the MNET/10 mode.

*2 This module has been discontinued.

2) Connecting to MELSEC-Q (coaxial bus system)

PLC		Connection cable	GOT	
MELSECNET/H module	Communication type		Option	GOT
QJ71BR11	MELSECNET/10	Coaxial cable	GT15-J71BR13 *1	GT2705-VTBD

*1 In the controller setting, set the MNET/10 mode.

(b) MELSECNET/H connection

Configure the connection as follows.

When replacing with the MELSECNET/H connection, a MELSECNET/H module is required on the PLC. On the GOT, a MELSECNET/H communication module is required.

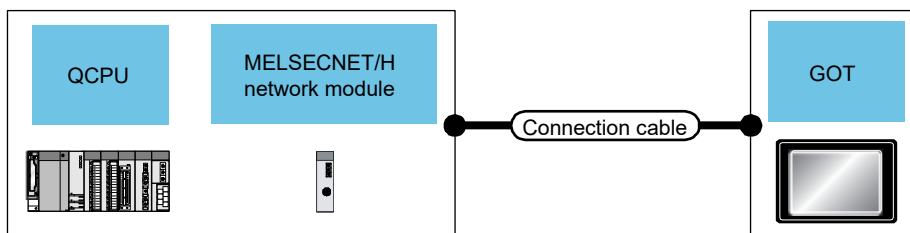

1) Connecting to MELSEC-Q (optical loop system)

PLC		Connection cable	GOT	
MELSECNET/H module	Communication type		Option	GOT
QJ71LP21 *1 QJ71LP21-25 QJ71LP21S-25	MELSECNET/H	Fiber-optic cable	GT15-J71LP23-25	GT2705-VTBD

*1 This module has been discontinued.

[Issue No.] GOT-A-0148-B

2) Connecting to MELSEC-Q (coaxial bus system)

PLC		Communication type	Connection cable	GOT	
MELSECNET/H module				Option	GOT
QJ71BR11	MELSECNET/H		Coaxial cable	GT15-J71BR13	GT2705-VTBD

(c) CC-Link connection (intelligent device station)

Configure the connection as follows.

When replacing with the CC-Link (intelligent device station) connection, a CC-Link module is required on the PLC.

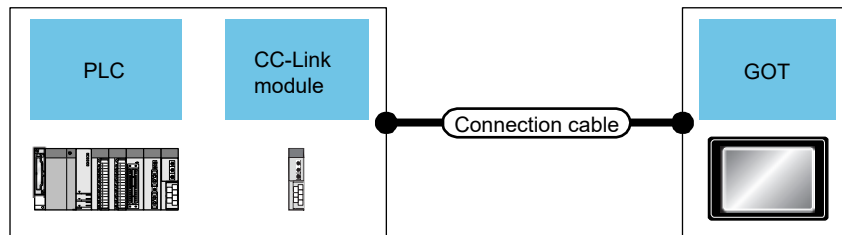

Connecting to MELSEC-Q

PLC		Communication type	Connection cable	GOT	
CC-Link module *1				Option	GOT
QJ61BT11 *5 QJ61BT11N	CC-Link(Ver.1)		CC-Link dedicated cable *2*3	GT15-J61BT15 *4	GT2705-VTBD

*1 For the system configuration for the CC-Link module, refer to the following manuals.

→ CC-Link System Master/Local Module User's Manual (SH-080016)

MELSEC-Q CC-Link System Master/Local Module User's Manual (SH-080394)

*2 For the specifications of CC-Link dedicated cables and contact, refer to the following.

→ CC-Link Partner Association website: <http://www.cc-link.org/>

*3 The maximum length of total extension cables and that of the cable between stations depends on the cable type to be used and the transmission speed.

For details, refer to the following manuals.

→ CC-Link System Master/Local Module User's Manual (SH-080016)

MELSEC-Q CC-Link System Master/Local Module User's Manual (SH-080394)

*4 In the controller setting, set the mode to Ver.1.

For details, refer to the following manual.

→ GOT2000 Series Connection Manual (Mitsubishi Electric Products) For GT Works3 Version1 (SH-081197ENG)

*5 This module has been discontinued.

[Issue No.] GOT-A-0148-B

(d) Ethernet connection

Configure the connection as follows.

When replacing with the Ethernet connection, an Ethernet module is required on the PLC.

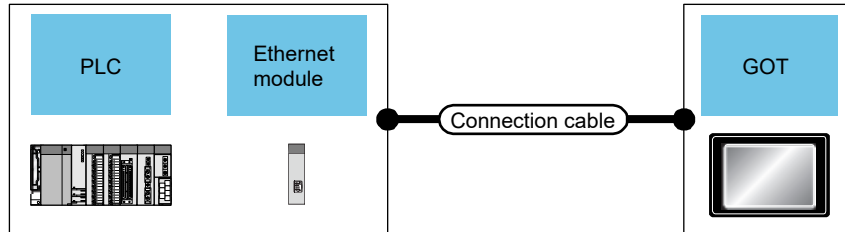

Connecting to MELSEC-Q

PLC		Connection cable	GOT	
Ethernet module	Communication type		Option	GOT
QJ71E71-100 QJ71E71-B5 *1 QJ71E71-B2 *1 QJ71E71 *1	Ethernet	Twisted cable - 10BASE-T - 100BASE-TX	(Built in the GOT)	GT2705-VTBD GT2505-VTBD

*1 This module has been discontinued.

[Issue No.] GOT-A-0148-B

(3) Replacement when multiple units are connected

Consider the following connection type when replacing the configuration where multiple units are connected.

- Network connection
 - 1.6.2 ■2. (2) Replacing with the network connection
- Multi-drop connection
 - (a) Multi-drop connection

(a) Multi-drop connection *1

Configure the connection as follows.

When replacing with the multi-drop connection, the following options and cables are required.

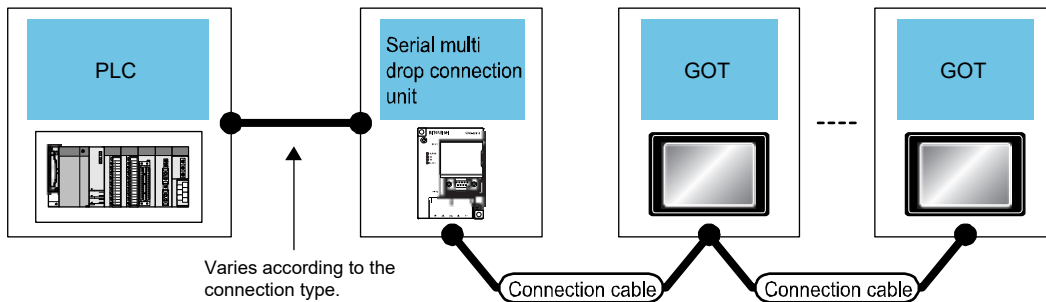

*1 If the number of connected slave GOTs or the number of devices of each GOT increase, the device update cycle on the screen may be delayed.
 In this case, it is recommended to reduce the number of devices of each GOT.
 (The standard number of devices is 250 per GOT, and 750 in total.)
 If a timeout error occurs, extend the timeout time with the controller setting of the slave GOT.

1) Connecting to MELSEC-Q *1

For the system configuration between the serial multi-drop connection unit and the PLC, refer to each connection type.

Multi-drop connection unit		Cable *2	GOT	
Serial multi-drop connection unit	Communication type		Option	GOT
GT01-RS4-M	RS-485	User-created cable (500 m max. *3)	(Built in the GOT)	GT2705-VTBD GT2505-VTBD
			GT15-RS4-9S	GT2705-VTBD
			GT15-RS4-TE	GT2705-VTBD

*1 The Ww and Wr devices cannot be monitored.
 *2 For the user-created cable, refer to the following.
 → GOT2000 Series Connection Manual (Mitsubishi Electric Products) For GT Works3 Version1 (SH-081197ENG)
 *3 This is the maximum distance between the PLC and the GOT (terminal).

2. Comparison in specifications

2.1 Comparison in hardware specifications

2.1.1 Comparison in performance specifications between GT115□-Q□BD(□)(-C) and GT2705-VTBD, GT2505-VTBD

The specifications in the gray cells are not changed by replacement.

Table 2-1 Comparison chart of performance specifications (GT115□-Q□BD(-C) and GT2505-VTBD)

Item		Model in use			Recommended model for replacement GT2505-VTBD
		GT1155- QTBD	GT1155- QSBD(-C)	GT1150- QLBD, GT1150- QBBD-C	
Conforming standard		CE (EMC), UL/cUL, KC			←
Display section	Type	TFT color LCD	STN color LCD	STN monochrome (black/white) LCD	TFT color LCD
	Screen size	5.7"			←
	Resolution	QVGA: 320 × 240 [dot]			VGA: 640 × 480 [dot]
	Display size	115 (W) × 86 (H) [mm]			←
	Number of displayed characters	16-dot standard font: 20 characters × 15 lines (two-byte characters) 12-dot standard font: 26 characters × 20 lines (two-byte characters)			16-dot standard font: 40 characters × 30 lines (two-byte characters) 12-dot standard font: 53 characters × 40 lines (two-byte characters)
	Display color	256 colors		GT1150-QLBD: Monochrome (black/white) 16 levels GT1150-QBBD: Monochrome (white/blue) 16 levels	65536 colors
	Brightness adjustment	8 levels			32 levels
Backlight	Type	Cold cathode fluorescent tube (not replaceable)			LED (not replaceable)
	Function	Backlight OFF Screen saving time settable			←
	Life *1	Approx. 75,000 hours		Approx. 54,000 hours	Approx. 60,000 hours
Touch panel	Type	Matrix resistive film			Analog resistive film
	Key size	Minimum 16 × 16 dots (per key)			Minimum 2 × 2 dots (per key)
	Simultaneous press	Max. 2			Not available
	Life	1 million touches or more (operating force: 0.98 [N] or less)			←
Memory	User memory	Built-in flash memory: 3MB Life (number of writings): 100 thousand			Storage memory (ROM): 32MB Operation memory (RAM): 80MB Life (number of writings): 100 thousand
	Built-in SRAM	Drive D: 512KB			SRAM user area: 500KB
Battery	Type	GT11-50BAT lithium battery			←
	Life	Approx. 5 years (ambient temperature: 25°C)			←
Built-in interface	Bus	Specification	-		←
	RS-422/485	Specification	1 channel, connector shape: D-sub 9-pin (female)		←
	RS-232	Specification	1 channel, connector shape: D-sub 9-pin (male)		←

[Issue No.] GOT-A-0148-B

Item		Model in use			Recommended model for replacement
		GT1155-QTBD	GT1155-QSBD(-C)	GT1150-QLBD, GT1150-QBBD-C	
Built-in interface	Ethernet	-			1 channel, data transfer method: 100BASE-TX/10BASE-T, connector shape: RJ-45 (modular jack)
	USB (host)	-			1 channel, maximum transfer rate: High-Speed 480 Mbps, connector shape: USB-A (back)
	USB (device)	1 channel, maximum transfer rate: Full-Speed 12 Mbps, connector shape: USB Mini-B (front)			1 channel, maximum transfer rate: High-Speed 480 Mbps, connector shape: USB Mini-B (front)
	SD/CF card	CF card: 1 channel, FAT16 format (max. 2GB) Not available to GT1155-QSBD-C and GT1150-QBBD-C.			SD card: 1 channel, SDHC-compatible (max. 32GB)
Buzzer output		Single tone (tone length adjustable)			Single tone (tone and tone length adjustable)
POWER LED		2 colors (green and orange)			2 colors (blue and orange)
Protective structure		IP67F (panel front face only)			←
External dimensions		164 (W) × 135 (H) × 56 (D) [mm]			164 (W) × 139 (H) × 55 (D) [mm]
Panel cutting dimensions		153 (W) × 121 (H) [mm]			←
Weight (excluding installation fitting)		0.7 kg			0.6 kg
Compatible software package		GT Designer3 Version1.00A or later GT1155-QSBD-C, GG1150-QBBD-C: GT Designer3 Version1.01B or later			GT Works3 Version1.180N or later
Installation direction		Horizontal or vertical			←
Control panel inside dimensions for installation		Refer to the following. → 2.4 Mounting intervals			Refer to the following. → 2.4 Mounting intervals
Installation position					

*1 Period when operating ambient temperature is 25°C and display intensity is 50%

Table 2-2 Comparison chart of performance specifications
(GT115□-Q□BD□ and GT2705-VTBD, GT2505-VTBD)

Item		Model in use			Recommended model for replacement	
		GT1155-QTBDA, GT1155-QTBDQ	GT1155-QSBDA, GT1155-QSBDQ	GT1150-QLBDA, GT1150-QLBDQ	GT2705-VTBD	GT2505-VTBD
Conforming standard		CE (EMC), UL/cUL, KC			←	
Display section	Type	TFT color LCD	STN color LCD	STN monochrome (black/white) LCD	TFT color LCD	
	Screen size	5.7"			←	
	Resolution [dot]	QVGA: 320 × 240			VGA: 640 × 480	
	Display size	115 (W) × 86 (H) [mm]			←	
	Number of displayed characters	16-dot standard font: 20 characters × 15 lines (two-byte characters) 12-dot standard font: 26 characters × 20 lines (two-byte characters)			16-dot standard font: 40 characters × 30 lines (two-byte characters) 12-dot standard font: 53 characters × 40 lines (two-byte characters)	
	Display color	256 colors		Monochrome (black/white) 16 levels	65536 colors	
Brightness adjustment	8 levels			32 levels		
Backlight	Type	Cold cathode fluorescent tube (not replaceable)			LED (not replaceable)	
	Function	Backlight OFF Screen saving time settable			←	
	Life *1	Approx. 75,000 hours		Approx. 54,000 hours	Approx. 60,000 hours	
Touch panel	Type	Matrix resistive film			Analog resistive film	
	Key size	Minimum 16 × 16 dots (per key)			Minimum 2 × 2 dots (per key)	
	Simultaneous press	Max. 2			Max. 2	Not available
	Life	1 million touches or more (operating force: 0.98 [N] or less)			←	
Memory	User memory	Built-in flash memory: 3MB Life (number of writings): 100 thousand			Storage memory (ROM): 32MB Operation memory (RAM): 80MB Life (number of writings): 100 thousand	
	Built-in SRAM	Drive D: 512KB			SRAM user area: 500KB	
Battery	Type	GT11-50BAT lithium battery			←	
	Life	Approx. 5 years (ambient temperature: 25°C)			←	
Built-in interface	Bus	Specification	QCPU (Q mode)/Motion controller CPU (Q series), 1 channel or QnA/ACPU/Motion controller CPU (A series), 1 channel		-	
	RS-422/485	Specification	-		1 channel, connector shape: D-sub 9-pin (female)	
	RS-232	Specification	1 channel, connector shape: D-sub 9-pin (male)		←	
	Ethernet		-		1 channel, data transfer method: 100BASE-TX/10BASE-T, connector shape: RJ-45 (modular jack)	
	USB (host)		-		2 channels, maximum transfer rate: High-Speed 480 Mbps, connector shape: USB-A (front/back)	1 channel, maximum transfer rate: High-Speed 480 Mbps, connector shape: USB-A (back)
	USB (device)		1 channel, maximum transfer rate: Full-Speed 12 Mbps, connector shape: USB Mini-B (front)		1 channel, maximum transfer rate: High-Speed 480 Mbps, connector shape: USB Mini-B (front)	
	SD/CF card		CF card: 1 channel, FAT16 format (max. 2GB)		SD card: 1 channel, SDHC-compatible (max. 32GB)	

[Issue No.] GOT-A-0148-B

Item	Model in use			Recommended model for replacement	
	GT1155- QTBDA, GT1155- QTBQ	GT1155- QSBDA, GT1155- QSBQ	GT1150- QLBDA, GT1150- QLBQ	GT2705-VTBD	GT2505-VTBD
Buzzer output	Single tone (tone length adjustable)			Single tone (tone and tone length adjustable)	
POWER LED	2 colors (green and orange)			2 colors (blue and orange)	
Protective structure	IP67F (panel front face only)			←	
External dimensions [mm]	167 (W) × 135 (H) × 65 (D)			167 (W) × 139 (H) × 60 (D)	164 (W) × 139 (H) × 55 (D)
Panel cutting dimensions [mm]	153 (W) × 121 (H)			←	
Weight (excluding installation fitting)	0.9 kg			1.0 kg	0.6 kg
Compatible software package	GT Designer3 Version1.00A or later			GT Works3 Version1.130L or later	GT Works3 Version1.180N or later
Installation direction	Horizontal or vertical			←	
Control panel inside dimensions for installation	Refer to the following. → 2.4 Mounting intervals			Refer to the following. → 2.4 Mounting intervals	
Installation position					

*1 Period when operating ambient temperature is 25°C and display intensity is 50%

[Issue No.] GOT-A-0148-B

2.1.2 Comparison in power supply section specifications between GT115□-Q□BD(□) and GT2705-VTBD, GT2505-VTBD

The specifications in the gray cells are not changed by replacement.

Table 2-3 Comparison chart of power supply section specifications
(GT115□-Q□BD□ and GT2705-VTBD, GT2505-VTBD)

Item	Model in use					Recommended model for replacement	
	GT1155-QTBD, GT1155-QSBD, GT1155-QSBD-C	GT1150-QLBD, GT1150-QBBD-C	GT1155-QTBDA, GT1155-QTBDDQ	GT1155-QSBDA, GT1155-QSBDQ	GT1150-QLBDA, GT1150-QLBDQ	GT2705-VTBD	GT2505-VTBD
Input power supply voltage	24 V DC (+10%, -15%) ripple voltage 200 mV or lower					←	
Power consumption (Under the maximum load)	9.84 W (410 mA/24 V)	9.36 W (390 mA/24 V)	11.16 W (465 mA/24 V)	9.72 W (405 mA/24 V)	7.92 W (330 mA/24 V)	30 W or less	8.4 W or less
Inrush current *1	15 A or lower (2 ms)		26 A or lower (4 ms)			69 A or lower (1 ms)	42A or lower (2 ms)
Permissible instantaneous power failure time	5 ms or less		10 ms or less			10 ms or less	
Noise immunity	Noise voltage: 1000 Vp-p, noise width: 1 μs (Measured by a noise simulator with noise frequency 30 to 100 Hz)		Noise voltage: 500 Vp-p, noise width: 1 μs (Measured by a noise simulator with noise frequency 25 to 60Hz)			Noise voltage: 500 Vp-p, noise width: 1 μs (Measured by a noise simulator with noise frequency 25 to 60Hz)	Noise voltage: 1000 Vp-p, noise width: 1 μs (Measured by a noise simulator with noise frequency 30 to 100 Hz)
Withstand voltage	500 V AC for 1 minute across power terminals and earth					←	
Insulation resistance	10 MΩ or more across power terminals and earth by a 500V DC insulation resistance tester					←	
Applicable wire size	For power: 0.75 [mm ²] or more, for grounding: 2 [mm ²] or more					←	
Applicable solderless terminal	Solderless terminal for M3 screw: RAV1.25-3, V2-S3.3, V2-N3A, FV2-N3A					←	

*1 Ambient temperature: 25°C, under the maximum load

2.1.3 Comparison in performance specifications between GT115□HS-Q□BD and GT2505HS-VTBD

The specifications in the gray cells are not changed by replacement.

Table 2-4 Comparison chart of performance specifications (Handy GOT)

Item		Model in use		Recommended model for replacement
		GT1155HS-QTBD	GT1150HS-QLBD	GT2505HS-VTBD
Conforming standard		CE (EMC), UL/cUL, KC		←
Display section	Type	TFT color LCD	STN monochrome (black/white) LCD	TFT color LCD
	Screen size	5.7"		←
	Resolution	QVGA: 320 × 240 [dot]		VGA: 640 × 480 [dot]
	Display size	115 (W) × 86 (H) [mm]		←
	Number of displayed characters	16-dot standard font: 20 characters × 15 lines (two-byte characters) 12-dot standard font: 26 characters × 20 lines (two-byte characters)		16-dot standard font: 40 characters × 30 lines (two-byte characters) 12-dot standard font: 53 characters × 40 lines (two-byte characters)
	Display color	256 colors	Monochrome (black/white) 16 levels	65536 colors
	Brightness adjustment	8 levels		32 levels
Backlight	Type	Cold cathode fluorescent tube (not replaceable)		LED (not replaceable)
	Function	Backlight OFF Screen saving time settable		←
	Life *1	Approx. 75,000 hours	Approx. 54,000 hours	Approx. 60,000 hours
Touch panel	Type	Matrix resistive film		Analog resistive film
	Key size	Minimum 16 × 16 dots (per key)		Minimum 2 × 2 dots (per key)
	Simultaneous press	Max. 2		Not available
	Life	1 million touches or more (operating force: 0.98 [N] or less)		←
Memory	User memory	Built-in flash memory: 3MB Life (number of writings): 100 thousand		Storage memory (ROM): 32MB Operation memory (RAM): 80MB Life (number of writings): 100 thousand
	Built-in SRAM	Drive D: 512KB		SRAM user area: 500KB
Battery	Type	GT11-50BAT lithium battery		←
	Life	Approx. 5 years (ambient temperature: 25°C)		←
Built-in interface	Bus	Spec	-	
	RS-422	Spec	1 channel each (Select 1 channel from RS-422/RS-232 (for PLC communication) to use) Connector shape: Round 32-pin (male)	
	RS-232 (for PLC communication)	Spec		
	RS-232 (for PC communication)	Spec	1 channel MINI-DIN 6-pin (female)	
	Ethernet		-	
	USB (host)		-	
	USB (device)		1 channel, maximum transfer rate: Full-Speed 12 Mbps, connector shape: USB Mini-B	
	SD/CF card		CF card: 1 channel, FAT16 format (max. 2GB)	

[Issue No.] GOT-A-0148-B

Item	Model in use		Recommended model for replacement
	GT1155HS-QTBD	GT1150HS-QLBD	GT2505HS-VTBD
Buzzer output	Single tone (tone length adjustable)		Single tone (tone and tone length adjustable)
POWER LED	2 colors (green and orange)		2 colors (blue and orange)
Protective structure	IP65F (when an external connection cable is connected)		←
External dimensions	176 (W) × 220 (H) × 93 (D) [mm]		145 (W) × 185 (H) × 79.3 (D) [mm]
Weight (Handy GOT only)	1.0 kg		0.79 kg
Compatible software package	GT Designer3 Version1.00A or later		GT Works3 Version1.195D or later

*1 Period when operating ambient temperature is 25°C and display intensity is 50%

2.1.4 Comparison in power supply section specifications between GT115□HS-Q□BD and GT2505HS-VTBD

The specifications in the gray cells are not changed by replacement.

Table 2-5 Comparison chart of power supply section specifications (Handy GOT)

Item	Model in use		Recommended model for replacement
	GT1155HS-QTBD	GT1150HS-QLBDE	GT2505HS-VTBD
Input power supply voltage	24 V DC (+10%, -15%) ripple voltage 200 mV or lower		←
Power consumption (Under the maximum load)	9.84 W (410 mA/24 V)	9.36 W (390 mA/24 V)	8.40 W or less
Inrush current *1	15 A or lower (2 ms)		30 A or lower (2 ms)
Permissible instantaneous power failure time	5 ms or less		←
Noise immunity	Noise voltage: 1000 Vp-p, noise width: 1 μs (Measured by a noise simulator with noise frequency 30 to 100 Hz)		←
Withstand voltage	500 V AC for 1 minute across power terminals and earth		←
Insulation resistance	10 MΩ or more across power terminals and earth by a 500V DC insulation resistance tester		←

*1 Ambient temperature: 25°C, under the maximum load

[Issue No.] GOT-A-0148-B

2.2 Comparison in external dimensions

■GT115□-Q□BD(-C)

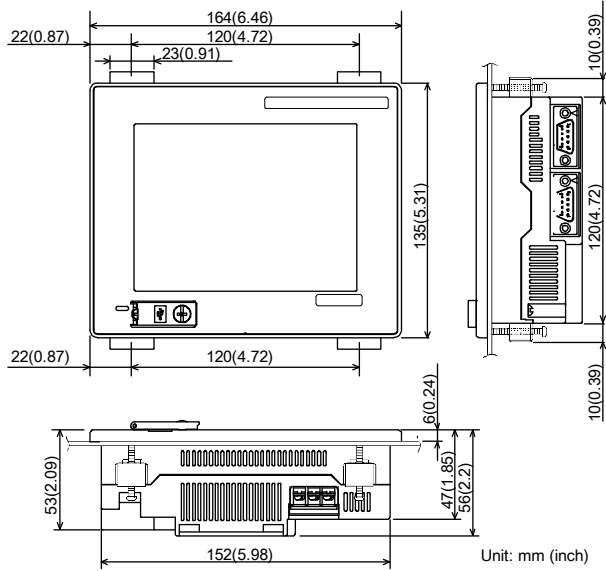

■GT115□-Q□BD□

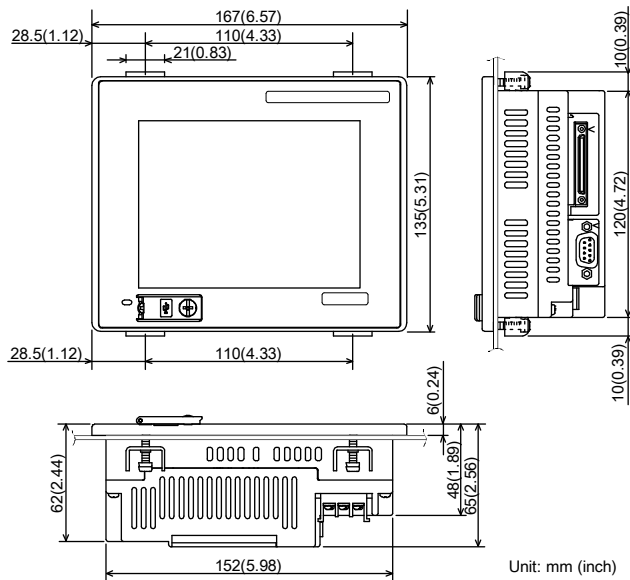

[Issue No.] GOT-A-0148-B

■GT2705-VTBD

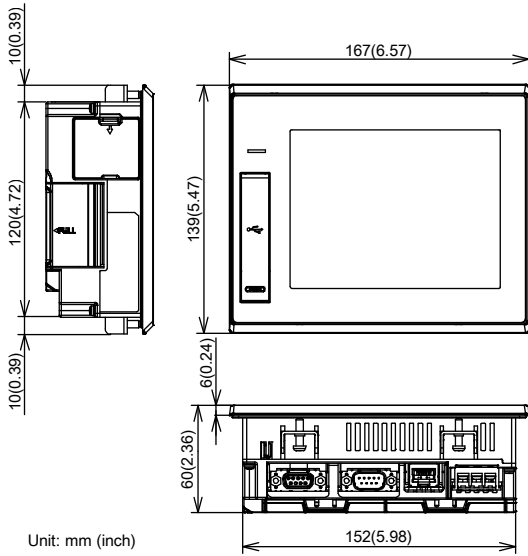

■GT2505-VTBD

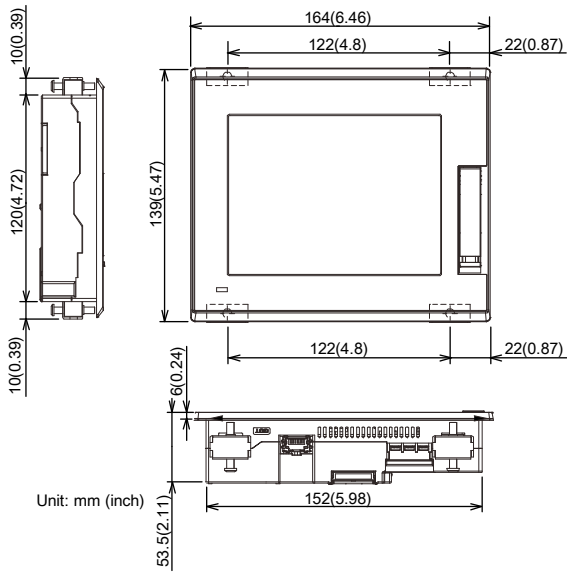

[Issue No.] GOT-A-0148-B

■GT11 handy model

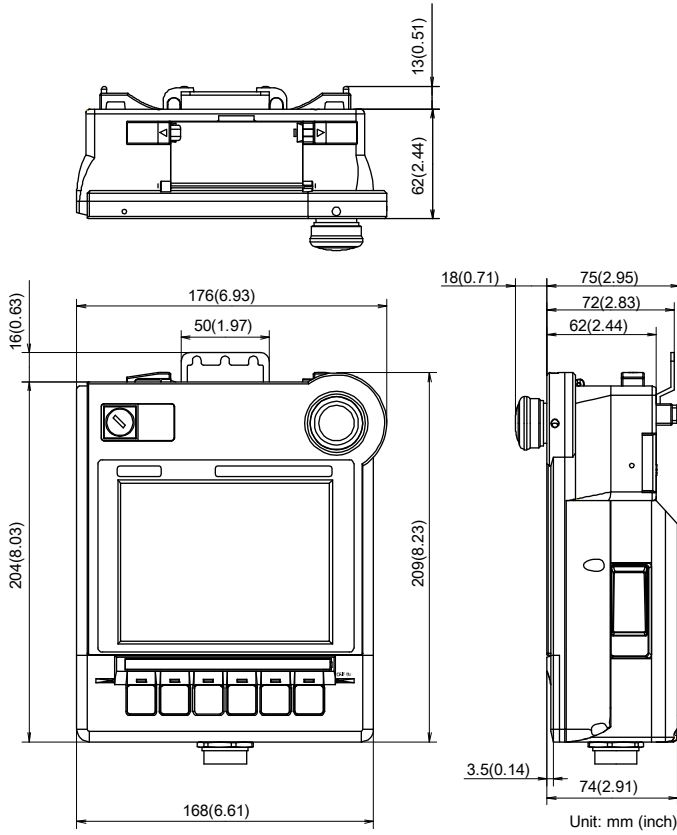

■GT2505HS-VTBD

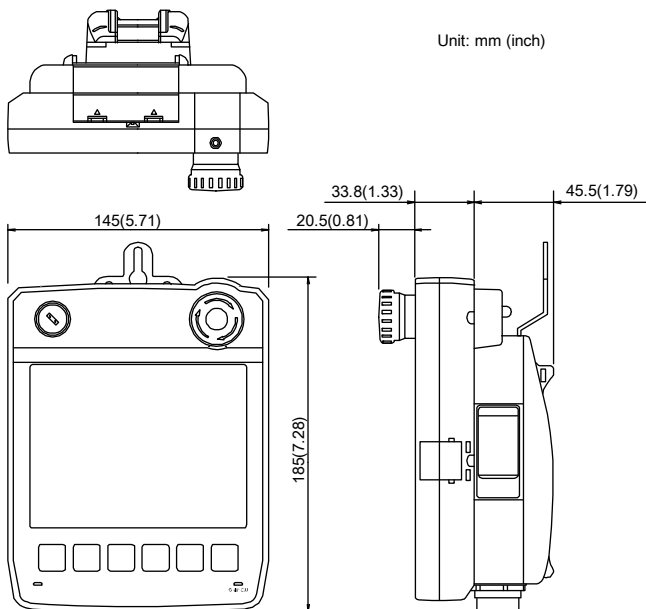

[Issue No.] GOT-A-0148-B

2.3 Comparison in panel cutting dimensions

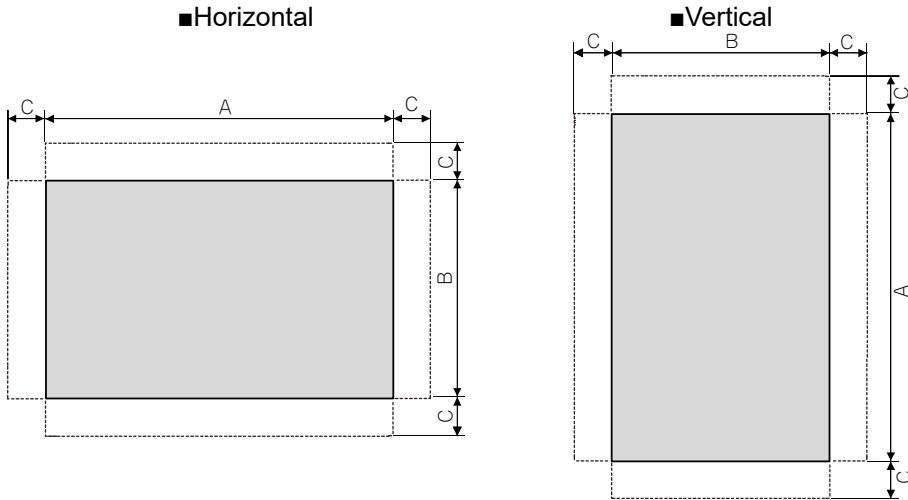

The specifications in the gray cells are not changed by replacement.

Item	Model in use	Recommended model for replacement	
	GT11 model	GT2705-VTBD	GT2505-VTBD
A	153 ⁺² ₀ mm (6.02 ^{+0.08} ₀ inch)	←	
B	121 ⁺² ₀ mm (4.76 ^{+0.08} ₀ inch)	←	
C	10 mm or more (0.39 inch or more)	←	
Panel thickness	2 to 4 mm (0.08 to 0.16 inch)	1.6 to 4 mm (0.06 to 0.16 inch)	

2.4 Mounting intervals

2.4.1 When replacing GT11 models with GT2705-VTBD

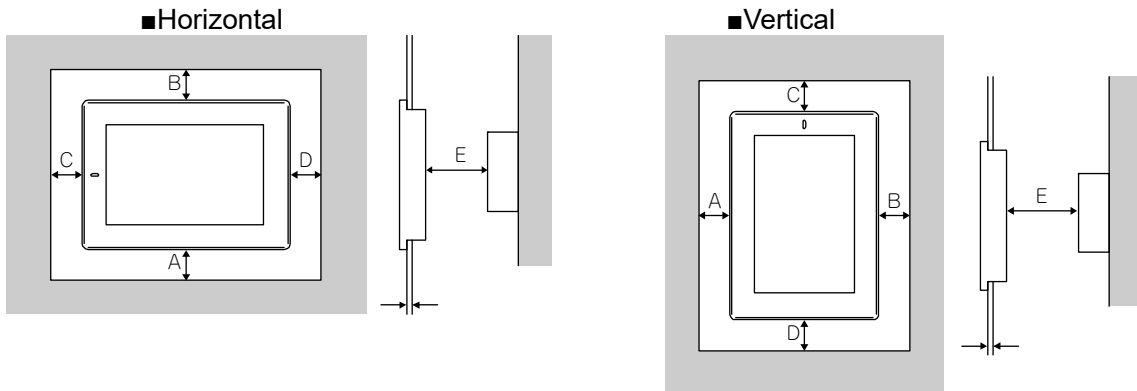

Figure 2-4-1-1 GT11 model

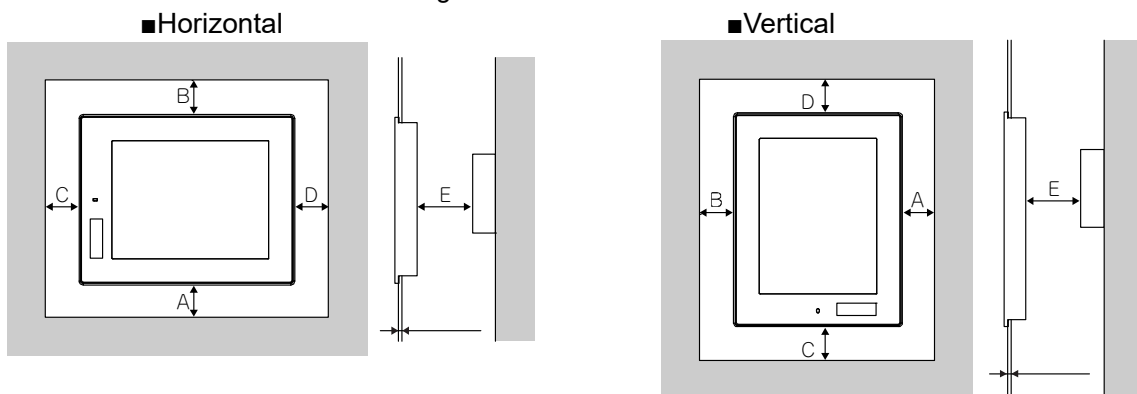

Figure 2-4-1-2 GT2705-VTBD

The specifications in the gray cells are not changed by replacement.

Item	Model in use	Recommended model for replacement
	GT11 model	GT2705-VTBD
A	50 mm or more (20 mm or more) [1.97 inch or more (0.79 inch or more)]	59 mm or more [2.32 inch or more]
B	Vertical: 80 mm or more (20 mm or more) [3.15 inch or more (0.79 inch or more)] Horizontal: 50 mm or more (20 mm or more) [1.97 inch or more (0.79 inch or more)]	Vertical: 78 mm or more (18 mm or more) [3.07 inch or more (0.71 inch or more)] Horizontal: 48 mm or more (18 mm or more) [1.89 inch or more (0.71 inch or more)]
C	When the CF card is used: 100 mm or more (100 mm or more) [3.94 inch or more (3.94 inch or more)] When the CF card is not used: Vertical: 50 mm or more (20 mm or more) [1.97 inch or more (0.79 inch or more)] Horizontal: 80 mm or more (20 mm or more) [1.97 inch or more (0.79 inch or more)]	When the SD card is used: 100 mm or more (100 mm or more) [3.94 inch or more (3.94 inch or more)] When the SD card is not used: 50 mm or more (20 mm or more) [1.97 inch or more (0.79 inch or more)]
D	50 mm or more (20 mm or more)	Vertical: 50 mm or more (20 mm or more) [1.97 inch or more (0.79 inch or more)] Horizontal: 80 mm or more (20 mm or more) [3.15 inch or more (0.79 inch or more)]
E	100 mm or more (20 mm or more) [3.94 inch or more (0.79 inch or more)]	←

* The dimensions within the parentheses apply when no equipment generating radiated noise (such as a contactor) or heat is installed near the GOT.

2.4.2 When replacing GT11 models with GT2505-VTBD

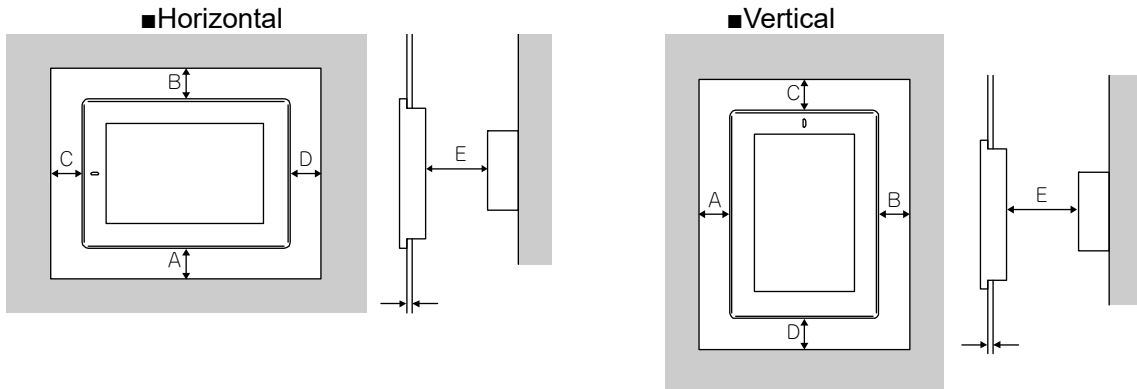

Figure 2-4-2-1 GT11 model

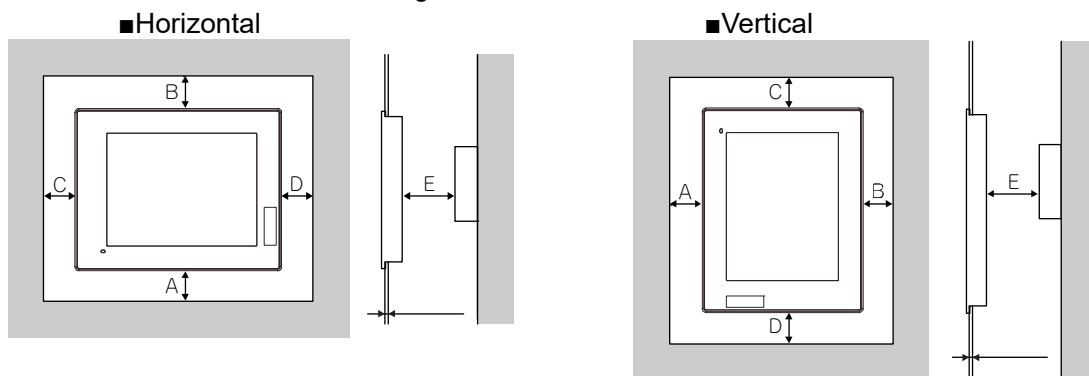

Figure 2-4-2-2 GT2505-VTBD

The specifications in the gray cells are not changed by replacement.

Item	Model in use	Recommended model for replacement
	GT11 model	GT2505-VTBD
A	50 mm or more (20 mm or more) [1.97 inch or more (0.79 inch or more)]	←
B	Vertical: 80 mm or more (20 mm or more) [3.15 inch or more (0.79 inch or more)] Horizontal: 50 mm or more (20 mm or more) [1.97 inch or more (0.79 inch or more)]	←
C	When the CF card is used: 100 mm or more (100 mm or more) [3.94 inch or more (3.94 inch or more)] When the CF card is not used: Vertical: 50 mm or more (20 mm or more) [1.97 inch or more (0.79 inch or more)] Horizontal: 80 mm or more (20 mm or more) [1.97 inch or more (0.79 inch or more)]	Vertical: 50 mm or more (20 mm or more) [1.97 inch or more (0.79 inch or more)] Horizontal: 80 mm or more (20 mm or more) [3.15 inch or more (0.79 inch or more)]
D	50 mm or more (20 mm or more) [1.97 inch or more (0.79 inch or more)]	←
E	100 mm or more (20 mm or more) [3.94 inch or more (0.79 inch or more)]	When the SD card is used: 100 mm or more (100 mm or more) [3.94 inch or more (3.94 inch or more)] When the SD card is not used: 100 mm or more (20 mm or more) [3.94 inch or more (0.79 inch or more)]

* The dimensions within the parentheses apply when no equipment generating radiated noise (such as a contactor) or heat is installed near the GOT.

2.5 Function specifications**2.5.1 Comparison in function specifications**

Most of the functions of the GOT1000 series can be used in the GOT2000 series, however, some functions are not supported or are integrated, or their names have been changed.

For details, refer to "Table 2-6 Comparison in GOT2000 function specifications".

For details of each function of the GOT2000 series, refer to the manual.

(1) Functions not supported by the GOT2000 series

- Data list display
- A list editor
- Connecting multiple GOTs

(2) Integrated functions and functions with changed names

Function name in the GOT1000 series	Function name in the GOT2000 series
Basic comment	Comment group
Comment group	
Alarm history, alarm history display	User alarm observation, alarm display (user)
Status observation function	Trigger action
Trigger action	
ASCII display, ASCII input	Text display, text input
User alarm display	Simple alarm display
Alarm scrolling	Alarm popup display
System monitor	Device monitor

2.5.2 Detailed comparison in function specifications

(1) Detailed comparison in function specifications

The following table shows the differences in the functions between the GOT1000 series and the GOT2000 series.

Table 2-6 Comparison in GOT2000 function specifications

Category	Function name in GOT1000	GT11	GT27, GT25	Precautions for replacing GOT1000 series with GOT2000 series	
Shape/object function	Shape	Shape	•	•	-
		Logo text	•	•	-
	Font type	Standard font	•	•	- Refer to 2.6.4 (2).
		HQ font	•	•	-
		TrueType font	•	•	-
		Windows font	•	•	-
	Common	Text	•	•	-
		Trigger type	•	•	-
		Offset device	•	•	- Refer to 2.6.4 (5).
		Number of colors	•	•	-
	Object	Touch switch	•	•	- The special function switches that are not supported by GOT2000 are replaced with [Utility]. - When multiple actions including ones to which no device has been set have been set on a switch in the [Action] tab, touching the switch may not perform actions after the action to which no device has been set.
			•	•	- The [Use Image Transparent] setting for when objects registered in the library are used will be deleted. Transparent color becomes effective in GOT2000 regardless of the settings in GOT1000.
		Lamp	•	•	-
		Numerical display, numerical input	•	•	-
		ASCII display, ASCII input	•	•	- Replaced with [Text Display] or [Text Input].
		Date display, time display	•	•	-
		Comment display	•	•	- When [16dot HQ Mincho] or [16dot HQ Gothic] is specified for the comment display (bit), the setting is replaced as follows. - When the text size (width × height) is any of 0.5, 1, 3, 5, or 7: The font selected in [16dot Standard Font] in the type setting of GOT1000. 2, 4, 6, or 8: [16dot HQ Mincho]
			Basic comment	•	•
		Comment group	•		
Parts display		•	•	- When [Fixed Parts Display] is used, [Rise] and [Fall] of the trigger type setting are replaced with [ON] and [OFF].	
Parts display	•	•	- When [Fixed Parts Display] is used, [Rise] and [Fall] of the trigger type setting are replaced with [ON] and [OFF].		
Parts movement	•	•	-		
Data list display	•	×	- Not supported by GOT2000.		

Category	Function name in GOT1000	GT11	GT27, GT25	Precautions for replacing GOT1000 series with GOT2000 series
Shape/object/function	User alarm display	•	•	<ul style="list-style-type: none"> - Replaced with [Simple Alarm Display]. - [Rise], [Fall], and [Sampling] of the trigger type setting are replaced with [Ordinary]. - Text alignment of the comment setting (multiple rows) will be deleted. - Texts are aligned [Left] in GOT2000 regardless of the setting of GOT1000. - [Store Memory] is not supported. When [Store Memory] is used, replace it with [User Alarm Observation] or [Alarm Display(User)].
	System alarm display	•	•	-
	Alarm history, alarm history display	•	•	<ul style="list-style-type: none"> - Replaced with [User Alarm Observation] or [Alarm Display(User)]. - Replaced with [Time (hh:mm)] when [Text] is set as the date/time format for [Occurred], [Restored], and [Checks] of the displayed items in [Alarm History Display]. - When [Create a CSV file simultaneously] is selected in [Alarm History], configure the setting again in [Alarm Common Setting] of [User Alarm Observation] on GOT2000. - GT2505-V cannot be saved in the drive D. - Use the data storage since it is replaced with the drive X. For the available drives, refer to 2.6.4 (3).
	Alarm scrolling	•	•	- Replaced with [Alarm Popup Display].
	Level	•	•	-
	Panel meter	•	•	- [Top 1/4], [Bottom 1/4], [Left 1/4], and [Right 1/4] are replaced with [Top 1/6], [Bottom 1/6], [Left 1/6], and [Right 1/6] respectively. The display size is not changed.
	Line graph	•	•	- [Locus] is not supported.
	Trend graph	•	•	- Replaced with [Historical Trend Graph] or [Logging] when [Store Memory] is set. However, this function will be deleted when the number of logging settings exceeds the upper limit.
	Bar graph	•	•	-
	Statistics bar graph	•	•	-
	Statistics pie graph	•	•	-
	Scatter graph	•	•	-
	Key window object	•	•	-
Function running in the background	Recipe	•	•	<ul style="list-style-type: none"> - The following functions are not supported. <ul style="list-style-type: none"> - Creating a recipe file if no recipe file is found at startup - Specifying the file register name - The format of the recipe file (CSV/Unicode text) differs. When using the recipe file of GOT1000, change the format into the one for GOT2000. For details, refer to Section 2.2.2(2). - GT2505-V cannot be saved in the drive D. - Use the data storage since it is replaced with the drive X. For the available drives, refer to 2.6.4 (3).
	Status observation function	•	•	<ul style="list-style-type: none"> - Replaced with [Trigger Action]. - Because the trigger action has no [Observation Cycle] setting, the setting is replaced with one of [ON Sampling], [OFF Sampling], and [Ordinary] in the [Trigger Type] setting when the [Observation Cycle] setting has been set. Thus, the operation timing in the first cycle may change.
	Trigger action	•		
	Time action	•	•	<ul style="list-style-type: none"> - GT2505-V cannot be saved in the drive D. - Use the data storage since it is replaced with the drive X. For the available drives, refer to 2.6.4 (3).

Category	Function name in GOT1000	GT11	GT27, GT25	Precautions for replacing GOT1000 series with GOT2000 series
Function running in the background	Project/Screen script	●	●	- The setting of [Cancel internal device (GD/GB) assignment delay] will be deleted. In GOT2000, the result of assignment of internal devices (GD/GB) is reflected immediately regardless of the setting in GOT1000. - [Perform script initial operation (screen/object) only when switching screens] is added to GOT2000. The setting will be replaced as follows. Not checked (compatible with GOT1000) - The trigger type of a script is replaced as shown below. - [Ordinary] → [Sampling] (Cycle time: 100 ms) - [ON] → [ON Sampling] (Cycle time: 100 ms) - [OFF] → [OFF Sampling] (Cycle time: 100 ms) - When the drive D is specified with file operation function, change the destination drive. For the available drives, refer to 2.6.4 (3).
	RFID function	●*1	●*2	-
Function using peripheral	Barcode reader	●*1	●*2	-
	Base screen	●	●	-
GOT function	Overlap window	●	●	-
	Superimpose window	●	●	-
	Dialog window	●	●	-
	Key window	●	●	-
	Language switching	●	●	-
	Connecting multiple GOTs	●	×	-
	System information	●	●	-
	Security level authentication	●	●	- The password input dialog of the security level authentication differs. - In GT11, the dialog where 0 to 9 and A to F can be entered is displayed. In GOT2000, the dialog where 0 to 9, A to Z, and a to z can be entered is displayed.
	Startup logo	●	●	-
	FA transparent	●	●	- The modem connection and RS-232 connection between the GOT and a personal computer are not supported.
Debug function	System monitor	●	●	- Replaced with [Device Monitor]. - The display method for device comments is the same as the one for the sequence program monitor.
	A list editor	●*4	×	- Not supported by GOT2000. - The special function switch [A List Editor] is replaced with [Utility].
	FX list editor	●*3	●	-

*1 Excluding GT11 Handy

*2 Excluding GT25 Handy

*3 Excluding GT11 dedicated to bus connection

*4 Excluding GT11Q dedicated to bus connection

●: Supported

×: Not supported by GOT2000

(2) Recipe files (CSV/Unicode text) of the recipe

The format of the recipe files (CSV/Unicode text) differs between the GOT1000 series and GOT2000 series. Thus, when using a recipe file (CSV/Unicode text) for the GOT1000 series in the GOT2000 series, change the format into the one for the GOT2000 series.

- (a) Convert the project data into the one for the GOT2000 series, and execute the recipe.
- (b) A recipe file for the GOT2000 series (CSV/Unicode text) is created in a specified drive.
- (c) Copy the device values in the recipe file for the GOT1000 series onto the corresponding section in the recipe file for the GOT2000 series created in (b).

- GOT1000 recipe file

:DATE	2014/1/31 12:38
:GROUP No.	1
:GROUP NAME	RECIPE1
:DEVICE	8
ITEM NAME	VALUE
	234
	421
	52
	-23
	534
	-3
	32
	0

Copy and paste these values onto the GOT2000 recipe file.

- GOT2000 recipe file (number of records: 1)

:GT2K_RECIPE	0				
:RECIPE_ID	1				
:RECIPE_NAME	RECIPE1				
:DEVICE_NUM	8				
:RECORD_NUM	1				
:DATE_ORDER	YYYY/MM/DD				
	hh:mm:ss				
:LOCAL_TIME	GMT+09:00				
:TIME_INF_ORDER	L				
	DEV_COMMENT	DEV_TYPE	DISP_TYPE	DEV_SIZE	1
:RECORD_NAME					
:RECORD_ATTR					
:UPDATE					2014/1/31.12:38.
1		BIN16	DEC		234
2		BIN16	DEC	1	421
3		BIN16	DEC	1	52
4		BIN16	DEC	1	-23
5		BIN16	DEC	1	534
6		BIN16	DEC	1	-3
7		BIN16	DEC	1	32
8		BIN16	DEC	1	0

[Issue No.] GOT-A-0148-B

2.6 Screen design software specifications

The project data used in the GOT1000 series can be converted into the project data for the GOT2000 series, and can be used as-is.

[Precautions]

This explanation is based on GT Works3 Version1.195D.

Once the project data is converted into the one for the GOT2000 series, it cannot be converted back into the one for the GOT1000 series.

2.6.1 Preparation before converting the project data

Install the following software into the personal computer in advance.

(1) When reading the project data for the GOT1000 series from a GOT

Install GT Designer3 (GOT1000) (GT Works3 Version1.195D or later) or Data Transfer Tool.

* This operation is not necessary if any project data to be converted is already in the personal computer.

(2) When converting the project data for the GOT2000 series

Install GT Designer3 (GOT2000) (GT Works3 Version1.195D or later).

For how to install the software, refer to the following. (Download the manual from MITSUBISHI ELECTRIC FA Global Website.)

- GT Works3 Installation Instructions (DVD version) (BCN-P5999-0066)

If your version is old, contact your local sales office for how to obtain the latest version.

2.6.2 Procedure for converting the project data**(1) Checking and saving the project data to be converted**

When the data to be converted is in the personal computer, check the storage location of the project data for the GOT1000 series. When no data to be converted is in the personal computer, connect the personal computer to the GOT1000 series, and read and save the project data using GT Designer3 (GOT1000) or Data Transfer Tool.

(2) Opening the project data to be converted

1) When the project data to be converted does not need to be edited

Open the project data to be converted with GT Designer3 (GOT2000), and select [Convert the project to GOT2000 data and edit it in GT Designer3 (GOT2000)].

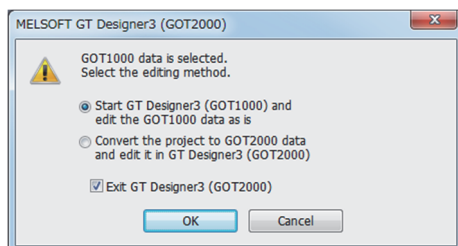

[Issue No.] GOT-A-0148-B

2) When converting the project data to be converted after editing
 Open the project data to be converted in GT Designer3 (GOT1000), edit the data, select [Common] - [GOT Type Setting], and select [GOT2000] for [Series] in GOT Type. Then, click "OK".

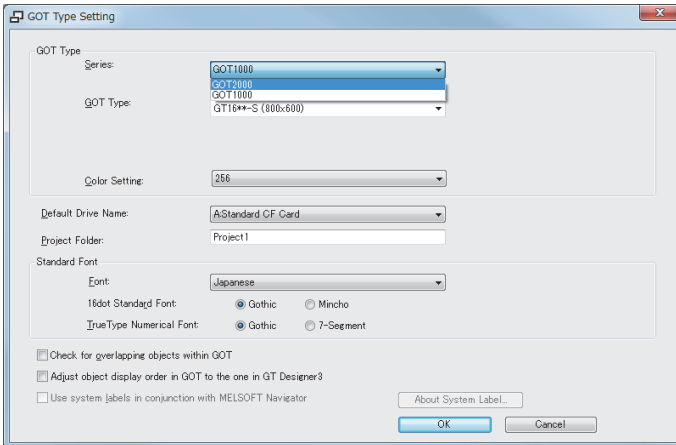

GT Designer3 (GOT2000) is started up.

(3) Converting the project data to be converted

Select the GOT2000 model to be replaced with and click "OK".

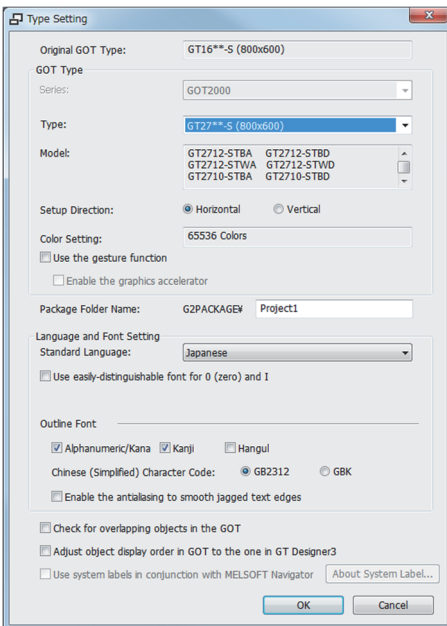

(4) The project data is converted for the GOT2000 series, and GT Designer3 (GOT2000) is started up. The changes can be checked in the output window.

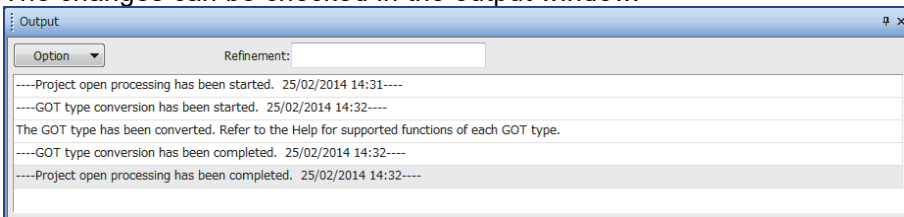

2.6.3 Unsupported screen design function

The following screen design function is not supported.

Category	Screen design function	GT11	GT27, GT25	Precautions for replacing GOT1000 series with GOT2000 series
Screen design software	Communication between the screen design software and GOT (modem, RS-232)	•	×	The modem or RS-232 connection between the screen design software (personal computer) and GOT is not supported. Use the USB or Ethernet connection.

- : Supported
- ×: Not supported by GOT2000

[Precautions]

Note that the settings of the functions that are not supported in the GOT2000 series are deleted when the GOT1000 series project data is converted for the GOT2000 series.

For compatibility of the functions between the GOT2000 series and GOT1000 series, refer to Section 3.5.

2.6.4 Other major changes

Major changes in the screen design function are as follows.

(1) Name of the OS (standard monitor OS, extended function OS)

The name is changed as follows.

In the GOT2000 series, the data necessary for GOT operations including system applications, project data, and communication drivers are collectively called "package data".

Name in GOT1000	Name in GOT2000
OS	System application
Standard monitor OS	Standard system application
Extended function OS	Advanced system application

(2) Name of standard fonts

The name and type of the standard fonts are changed as follows.

Name in GOT1000	Precautions and names for replacing GOT1000 with GOT2000
Japanese *1	Japanese *3 * Replaced with a font equivalent to Japanese (supporting Europe) of the GOT1000 series.
Japanese (supporting Europe) *2	Japanese *3
Chinese (Simplified) *1	Chinese (Simplified) *3 * Replaced with a font equivalent to Chinese (Simplified) (supporting Europe) of the GOT1000 series.
Chinese (Simplified) (supporting Europe) *2	Chinese (Simplified) *3
Chinese (Traditional) (supporting European) *2	Chinese (Traditional) *3

*1 European characters (Latin-1 Supplement, Latin Extended-A, Basic Greek, and Cyrillic) are displayed in two-byte characters.

*2 European characters (Latin-1 Supplement, Latin Extended-A, Basic Greek, and part of Cyrillic) are displayed in one-byte characters.

*3 European characters (Latin-1 Supplement, Latin Extended-A, Latin Extended-B, IPA Extensions, Latin Extended Additional, Basic Greek, Greek Extended, and part of Cyrillic) are displayed in one-byte characters.

(3) Drive configuration of the GOT

The name and type (media) of drives are different as follows.

Drive name	Drive type		
	GT11	GT27	GT25
Drive A	Standard CF card	Standard SD card	←
Drive C	Built-in flash memory	Built-in flash memory	←
Drive D	Built-in SRAM	-	←
Drive E	-	USB (assigned in order of connection)	←
Drive F	-	USB (assigned in order of connection)	←
Drive G	-	USB (assigned in order of connection)	←
Drive X (current drive)	-	A drive that is running a project. (Note that it indicates the drive A when the project is started from the drive C.)	←

(4) Storage locations of data

The storage locations of data are different as follows.

Data type	Storage drive		
	GT11	GT27	GT25
OS	Drive A, C	Package data	←
Project data	Drive A, C * Only the drive A can be used when the OS is stored in the drive A.	Drive A, C, E, F, G * The project data and system application cannot be stored in a different drive. * Only the drive A can be used for direct startup from a memory card.	
Resource data	Drive A, D * Storage locations differ depending on the type.	Drive A, E, F, G	←

[Issue No.] GOT-A-0148-B

(5) Offset value setting

When offsets are used and the following conditions are satisfied, the values to be stored in the offset devices must be changed.

- 1) Conditions requiring changes
 - Controller: OMRON PLC
 - Connection type: Ethernet connection
 - Offset-target device: Bit devices (., LR, HR, WR, and AR)

2) Change method

Values to be stored in the offset devices can be calculated using the following expression. Store the calculated values in the offset devices.

$$\text{Offset value for the GOT2000 series} = (\text{Offset value for the GOT1000 series}) / 100 \times 16 + (\text{Offset value for the GOT1000 series}) \% 100$$

* % means the division to calculate a remainder. (For "a % b", a remainder after "a" is divided by "b".)

Example) The following shows an example of offset values for the device LR00000.

Object setting in the GOT	Device number after the offset is added	Offset value for the GOT1000 series (decimal)	Offset value for the GOT2000 series (decimal) (calculated by the expression)
LR00000	LR00010	10	10
	LR00100	100	16
	LR00310	310	58
	LR010000	10000	1600

3) Differences in the specifications of the offsets of bit devices (., LR, HR, WR, and AR)

In the GOT1000 series, values must be set corresponding to the device notation (channel number and bit position). In the GOT2000 series, values disregarding channel numbers are set while bit devices are considered continuous.

Example) The following shows an example for the GOT1000 series.

Offset	Device indicated by the monitor device
Offset value = 0 (no offset)	LR00000
Offset value = 1	LR00001
Offset value = 15	LR00015
Offset value = 16	322 (range error)
Offset value = 100	LR00100
Offset value = 115	LR00115

*1 The following shows the bit device representation. (LR is used as an example).



*2 The lower two digits of the offset value are applied as an offset value for the bit position (*1). The valid value is 0 to 15. If 16 to 99 is set, the system alarm 322 "Dedicated device is out of range. Confirm device range." is displayed. The values excluding the lower two digits of the offset value are applied as an offset value for the channel number.

[Issue No.] GOT-A-0148-B

Example) The following shows an example for the GOT2000 series.

Offset	Device indicated by the monitor device
Offset value = 0 (no offset)	LR00000
Offset value = 1	LR00001
Offset value = 15	LR00015
Offset value = 16	LR00100
Offset value = 100	LR00604
Offset value = 115	LR00703

*1 The following shows the device representation for devices (... LR, HR, WR, and AR). (LR is used as an example.)

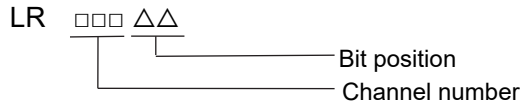

*2 As the offset value of the bit position is increased by 16, the channel number increases by 1.

REVISIONS

Version	Print Date	Revision
-	November 2019	- First edition (Japanese only)
A	December 2019	- Writing errors have been corrected.
B	July 2021	- Writing errors have been corrected.