

**Production Discontinuation of Tension Controllers LE-40MT Series and LE-30CTN(A)**

## ■Date of Issue

April 2021

## ■Relevant Models

LE-40MTA(-E), LE-40MTB(-E), LE-30CTN(A), LE-40MD

Thank you for your continued support of Mitsubishi Electric tension controllers.

For the tension controllers LE-40MT series and LE-30CTN(A), difficulty obtaining main parts has resulted in difficulty maintaining our production system.

Therefore, we are discontinuing production of the relevant models according to the following schedule. Thank you for your understanding.

For alternative models, refer to the following.

☞ Page 2 ALTERNATIVE MODELS

**1 MODELS TO BE DISCONTINUED**

Product	Model
Tension controller	LE-40MTA
	LE-40MTA-E
	LE-40MTB
	LE-40MTB-E
	LE-30CTN(A)
Reel diameter calculation module	LE-40MD

**2 SCHEDULE**

Start of made-to-order production: October 1, 2021

Order acceptance: Until February 29, 2024

Production discontinuation: March 29, 2024

Orders will no longer be accepted starting March 29, 2024, and production will end once ordered products have been shipped.

**3 REASON FOR DISCONTINUATION**

Difficulty obtaining main parts has resulted in difficulty maintaining our production system. The successor model LE7-40GU-L has been released.

**4 REPAIR SUPPORT**

Repair support period: Until March 31, 2031

We will support the repair orders accepted until March 31, 2031. (Note that we may not repair the products if the parts are no longer available even during the repair support period.)

CT-A-0005-A

## 5 ALTERNATIVE MODELS

Model to be discontinued	Alternative model		Compatibility
	Model	Product	
LE-40MTA(-E)	Tension controller	LE7-40GU-L	<ul style="list-style-type: none"> <li>• Functions are compatible. (☞ Page 3 Replacement From the LE-40MTA(-E))</li> <li>• When a powder clutch or brake with a rated current of 2.7A or higher is used, an amplifier (sold separately) for clutches is required.</li> <li>• Mounting method is incompatible.</li> </ul> When installing the controllers on the panel, use in conjunction with the LE7-ATT attachment (sold separately). (☞ Page 11 LE7-ATT ATTACHMENT)
LE-40MTB(-E)			<ul style="list-style-type: none"> <li>• Functions are compatible. (☞ Page 5 Replacement From the LE-40MTB(-E))</li> <li>• When a powder clutch or brake with a rated current of 2.7A or higher is used, an amplifier (sold separately) for clutches is required.</li> <li>• When the LE-40MD is used, the LE7-DCA diameter calculation option (sold separately) is required.</li> <li>• When the CC-Link communications function is used, the LE7-CCL network option (sold separately) is required.</li> <li>• Mounting method is incompatible.</li> </ul> When installing the controllers on the panel, use in conjunction with the LE7-ATT attachment (sold separately). (☞ Page 11 LE7-ATT ATTACHMENT)
LE-30CTN(A)			<ul style="list-style-type: none"> <li>• Functions are compatible. (☞ Page 7 Replacement From the LE-30CTN(A))</li> <li>• When a powder clutch or brake with a rated current of 2.7A or higher is used, an amplifier (sold separately) for clutches is required.</li> <li>• Mounting method is incompatible.</li> </ul> When installing the controllers on the panel, use in conjunction with the LE7-ATT attachment (sold separately). (☞ Page 11 LE7-ATT ATTACHMENT)
LE-40MD	Reel diameter calculation option	LE7-DCA	<ul style="list-style-type: none"> <li>• Functions are compatible. (☞ Page 9 Replacement From the LE-40MD)</li> <li>• Mounting method is incompatible. (Mounted in the LE7-40GU-L.)</li> <li>• The LE7-DCA diameter calculation option (sold separately) is only compatible with the LE7-40GU-L. Therefore, mount it before using.</li> </ul>

For a comparison of basic specifications, refer to the following.

☞ Page 3 COMPARISON OF BASIC SPECIFICATIONS BETWEEN MODELS TO BE DISCONTINUED AND ALTERNATIVE MODELS

For more detailed comparison of specifications related to the terminal layout and settings, refer to the following.

📖 Transition from LE-40MT Series, LE-30CTN(A) to LE7-40GU-L Handbook (SH-170028ENG)

CT-A-0005-A

## 6 COMPARISON OF BASIC SPECIFICATIONS BETWEEN MODELS TO BE DISCONTINUED AND ALTERNATIVE MODELS

### 6.1 Replacement From the LE-40MTA(-E)

Item	Model to be discontinued	Alternative model
Product	Tension controller	Tension controller
Model	LE-40MTA LE-40MTA-E	LE7-40GU-L
Function	Feedback control function	Feedback control function Open-loop control function (ratio calculation) <sup>*1</sup> Feed Forward/Feedback Combined Control function <sup>*1</sup>
Power supply	100 to 240VAC, 50/60Hz Built-in power fuse 250V, 8A	100 to 240VAC, 50/60Hz Built-in power fuse 250V, 8A × 2
Rated output	Control output for 24VDC series powder clutch/brake 0 to 24VDC, 4A or less	Control output for 24VDC series powder clutch/brake 0 to 24VDC, 2.7A or less <sup>*2</sup>
Terminal block	Screw type (fixed)	Spring clamp type (removable type: signal terminal only)
Corresponding tension detector	<ul style="list-style-type: none"> <li>• LX-TD tension detector</li> <li>• LX7-F tension detector</li> </ul>	<ul style="list-style-type: none"> <li>• LX-TD tension detector</li> <li>• LX7-F tension detector</li> <li>• Strain gauge sensor (2mV/V)</li> </ul>
Power consumption	400VA	200VA
Operating ambient temperature	0 to +40°C	0 to +40°C
External dimensions	156 × 246 × 156.5mm	105 × 170 × 125mm
Weight	Approx. 3.5kg	Approx. 1.0kg
Mounting method	Mounted on the panel Mounted on the floor Mounted on the wall	Mounted on the panel Mounted on the floor
Mounting method compatibility	None When installing the controllers on the panel, use in conjunction with the LE7-ATT attachment (sold separately). (☞ Page 11 LE7-ATT ATTACHMENT)	

\*1 When the open-loop control function or Feed Forward/Feedback Combined Control function is used, the LE7-DCA reel diameter calculation option (sold separately) is required.

\*2 The rated current of the LE7-40GU-L is 2.7A. When a powder clutch or brake with a rated current of 2.7A or higher is used, an amplifier (sold separately) for clutches is required.

CT-A-0005-A

External dimensions

LE-40MTA, LE-40MTA-E

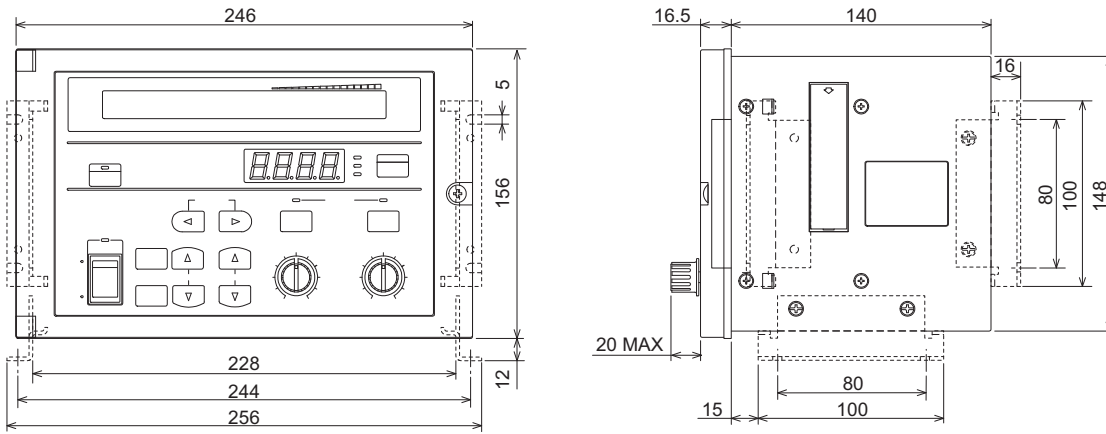

(Unit: mm)

LE7-40GU-L

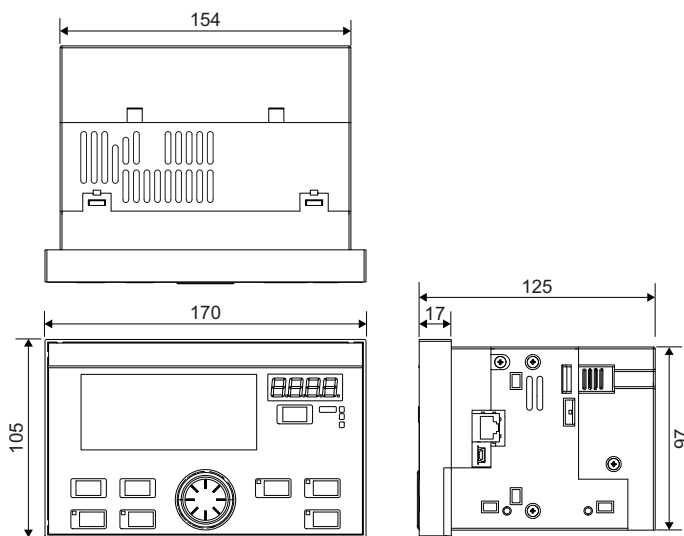

Accessories

- Mounting bracket: 2
- Screw (M4 × 10): 4
- Screw (M4 × 6): 2

Panel cutout dimensions

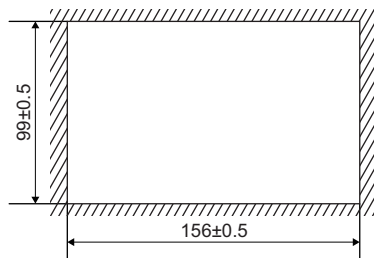

(Unit: mm)

CT-A-0005-A

## 6.2 Replacement From the LE-40MTB(-E)

Item	Model to be discontinued	Alternative model
Product	Tension controller	Tension controller
Model	LE-40MTB LE-40MTB-E	LE7-40GU-L
Function	Feedback control function	Feedback control function Open-loop control function (ratio calculation) <sup>*1</sup> Feed Forward/Feedback Combined Control function <sup>*1</sup>
Power supply	100 to 240VAC, 50/60Hz Built-in power fuse 250V, 8A	100 to 240VAC, 50/60Hz Built-in power fuse 250V, 8A × 2
Rated output	Control output for 24VDC series powder clutch/brake 0 to 24VDC, 4A or less	Control output for 24VDC series powder clutch/brake 0 to 24VDC, 2.7A or less <sup>*2</sup>
Reel diameter calculation module	Reel diameter calculation module LD-40MD	Reel diameter calculation option LE7-DCA <sup>*3</sup>
Communications function	Functions installed as standard • Parallel link communications with FX2N series programmable controllers	Functions installed as standard • N:N Network communications • MODBUS communications (RTU/ASCII/TCP) <sup>*4</sup> • CC-Link IE Field Network Basic • SLMP <sup>*4</sup> • USB communications (communications using MX Sheet/GT Designer3) <sup>*5</sup>
	Communications functions that are added when the FX2N-32CCL CC-Link interface module is connected • CC-Link (Ver.1.10)	Communications functions that are added when the LE7-CCL network option is connected <sup>*6</sup> • CC-Link (Ver.1.10/Ver.2.00)
Terminal block	Screw type (fixed)	Spring clamp type (removable type: signal terminal only)
Corresponding tension detector	• LX-TD tension detector • LX7-F tension detector	• LX-TD tension detector • LX7-F tension detector • Strain gauge sensor (2mV/V)
Power consumption	400VA	200VA
Operating ambient temperature	0 to +40°C	0 to +40°C
External dimensions	156 × 246 × 156.5mm	105 × 170 × 125mm
Weight	Approx. 3.5kg	Approx. 1.0kg
Mounting method	Mounted on the panel Mounted on the floor Mounted on the wall	Mounted on the panel Mounted on the floor
Mounting method compatibility	None When installing the controllers on the panel, use in conjunction with the LE7-ATT attachment (sold separately). (☞ Page 11 LE7-ATT ATTACHMENT)	

\*1 When the open-loop control function or Feed Forward/Feedback Combined Control function is used, the LE7-DCA reel diameter calculation option (sold separately) is required.

\*2 The rated current of the LE7-40GU-L is 2.7A. When a powder clutch or brake with a rated current of 2.7A or higher is used, an amplifier (sold separately) for clutches is required.

\*3 The LE7-DCA reel diameter calculation option (sold separately) is exclusive to the LE7-40GU-L. Do not use this option on its own or with other models.

\*4 To use SLMP or MODBUS/TCP communications, change screen data.

\*5 To use USB communications, the MX Component or GT Designer3 (sold separately) is required.

\*6 The LE7-CCL network option (sold separately) is only compatible with the LE7-40GU-L. Do not use this option on its own or with other models.

CT-A-0005-A

External dimensions

LE-40MTB, LE-40MTB-E

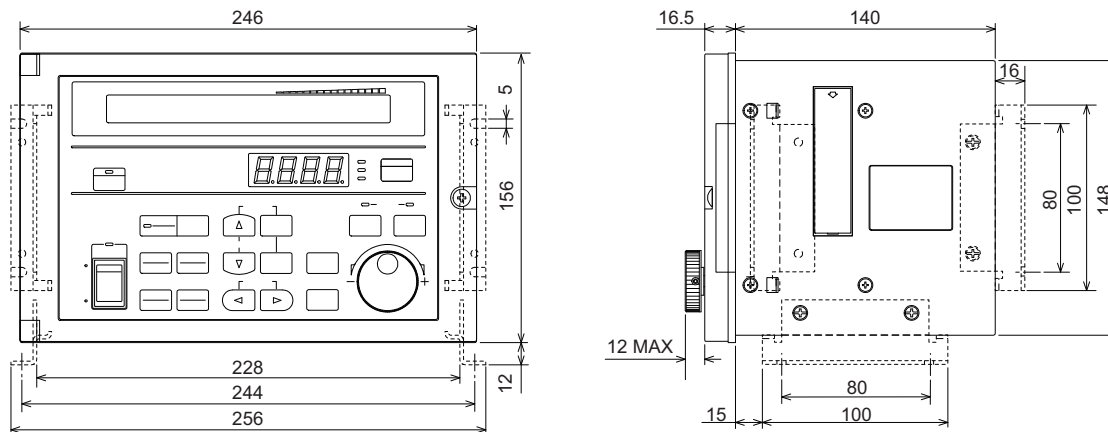

(Unit: mm)

LE7-40GU-L

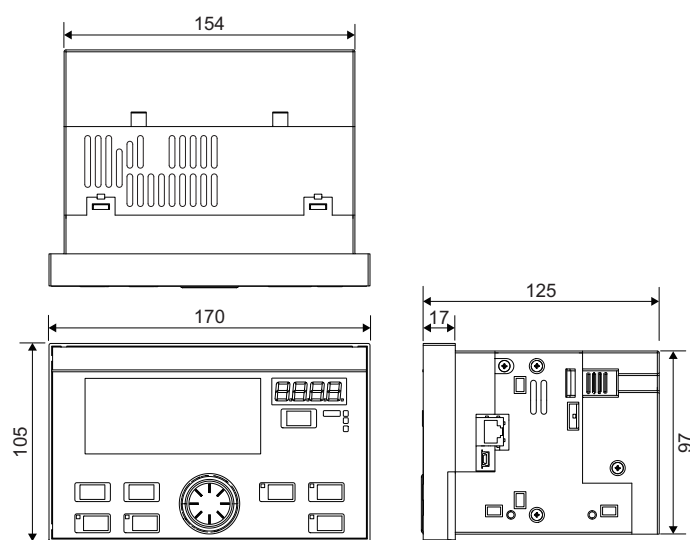

Accessories

- Mounting bracket: 2
- Screw (M4 × 10): 4
- Screw (M4 × 6): 2

Panel cutout dimensions

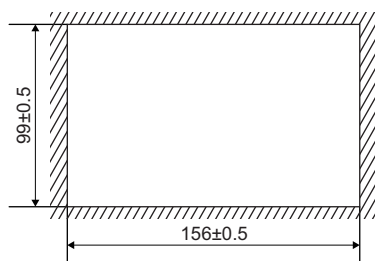

(Unit: mm)

CT-A-0005-A

### 6.3 Replacement From the LE-30CTN(A)

Item	Model to be discontinued	Alternative model
Product	Tension controller	Tension controller
Model	LE-30CTN(A)	LE7-40GU-L
Function	Feedback control function	Feedback control function Open-loop control function (ratio calculation) <sup>*1</sup> Feed Forward/Feedback Combined Control function <sup>*1</sup>
Power supply	100 to 240VAC, 50/60Hz Built-in power fuse 250V, 8A	100 to 240VAC, 50/60Hz Built-in power fuse 250V, 8A × 2
Rated output	Control output for 24VDC series powder clutch/brake 0 to 24VDC, 3A or less	Control output for 24VDC series powder clutch/brake 0 to 24VDC, 2.7A or less <sup>*2</sup>
Terminal block	Screw type (fixed)	Spring clamp type (removable type: signal terminal only)
Corresponding tension detector	<ul style="list-style-type: none"> <li>• LX-TD tension detector</li> <li>• LX7-F tension detector</li> </ul>	<ul style="list-style-type: none"> <li>• LX-TD tension detector</li> <li>• LX7-F tension detector</li> <li>• Strain gauge sensor (2mV/V)</li> </ul>
Power consumption	400VA	200VA
Operating ambient temperature	0 to +40°C	0 to +40°C
External dimensions	156 × 246 × 156.5mm	105 × 170 × 125mm
Weight	Approx. 3.5kg	Approx. 1.0kg
Mounting method	Mounted on the panel Mounted on the floor Mounted on the wall	Mounted on the panel Mounted on the floor
Mounting method compatibility	None When installing the controllers on the panel, use in conjunction with the LE7-ATT attachment (sold separately). (☞ Page 11 LE7-ATT ATTACHMENT)	

\*1 When the open-loop control function or Feed Forward/Feedback Combined Control function is used, the LE7-DCA reel diameter calculation option (sold separately) is required.

\*2 The rated current of the LE7-40GU-L is 2.7A. When a powder clutch or brake with a rated current of 2.7A or higher is used, an amplifier (sold separately) for clutches is required.

CT-A-0005-A

External dimensions

LE-30CTN(A)

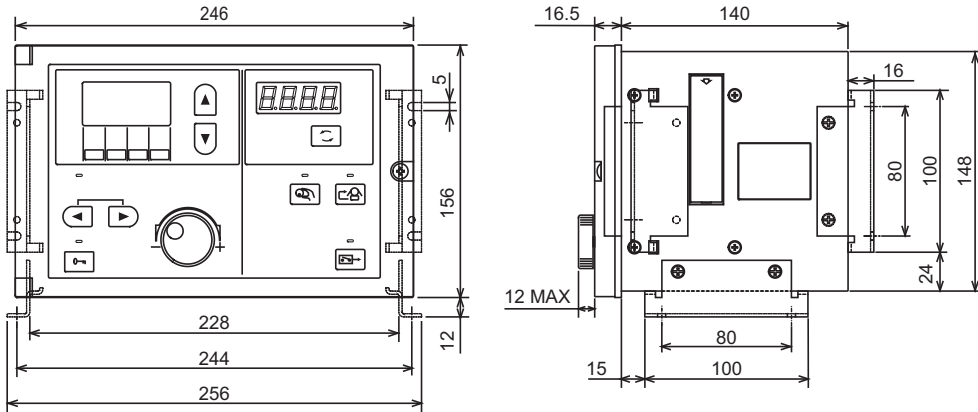

(Unit: mm)

LE7-40GU-L

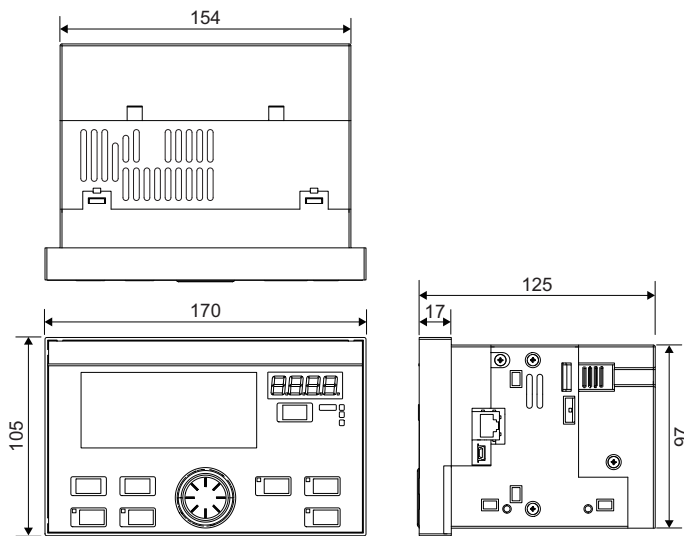

Accessories

- Mounting bracket: 2
- Screw (M4 × 10): 4
- Screw (M4 × 6): 2

Panel cutout dimensions

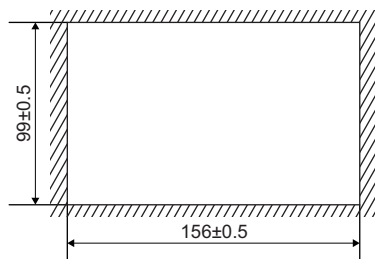

(Unit: mm)



CT-A-0005-A

## 6.4 Replacement From the LE-40MD

Item	Model to be discontinued	Alternative model
Product	Reel diameter calculation module	Reel diameter calculation option
Model	LE-40MD	LE7-DCA
Reel diameter calculation	Ratio calculation	Ratio calculation
Function	<ul style="list-style-type: none"> <li>• Measurement length/remaining length detection</li> <li>• Reel diameter detection</li> <li>• High-performance two-reel's switching function</li> </ul>	<ul style="list-style-type: none"> <li>• Measurement length/remaining length detection</li> <li>• Reel diameter detection</li> <li>• High-performance two-reel's switching function</li> <li>• Inertia compensation function</li> <li>• Open-loop control function</li> </ul>
Power supply	100 to 240VAC Power fuse 250V, 3A	Supplied from the LE7-40GU-L.
Terminal block	Screw type (fixed)	Spring clamp type (removable type)
Operating ambient temperature	0 to +40°C	0 to +40°C
External dimensions	140 × 150 × 95mm	50 × 68 × 35mm
Weight	Approx. 1.2kg	Approx. 0.2kg
Mounting method <sup>*1</sup>	Mounted using DIN rail Mounted on the wall	The option is mounted in the dedicated space inside the LE7-40GU-L.
Mounting method compatibility	None	

\*1 There is dedicated space for mounting the reel diameter calculation option inside the LE7-40GU-L. Additional space is not required.

## External dimensions

### LE7-DCA

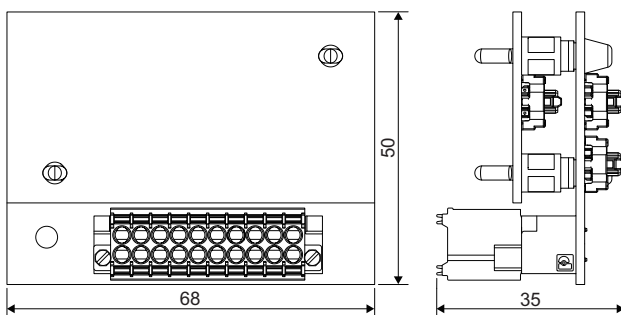

(Unit: mm)

#### Accessories

- Mounting screw (M3 × 8): 1

CT-A-0005-A

## 6.5 Functions of Network Option

Item	CC-Link system interface block	Network option
Product	FX2N-32CCCL	LE7-CCL
Station type	Remote device station	Remote device station
Version of CC-Link	Ver.1.00	Ver.1.10, Ver.2.00
Power supply	5VDC internal power supply: Via an extension cable 24VDC external power supply (24VDC ±10%)	Supplied from the LE7-40GU-L.
Terminal block	Screw type (fixed)	Spring clamp type (fixed)
Operating ambient temperature	0 to +40°C	0 to +40°C
External dimensions	90 × 43 × 87mm	50 × 68 × 38mm
Weight	Approx. 0.2kg	Approx. 0.2kg
Mounting method <sup>*1</sup>	Mounted using DIN rail Mounted on the wall	The option is mounted in the dedicated space inside the LE7-40GU-L.
Mounting method compatibility	None	

\*1 There is dedicated space for mounting the network option inside the LE7-40GU-L. Additional space is not required.

## External dimensions

### LE7-CCL

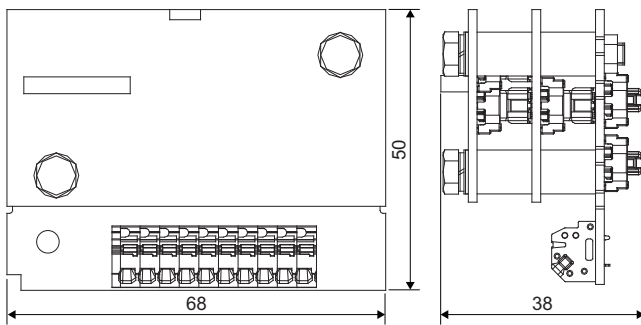

(Unit: mm)

#### Accessories

- Mounting screw (M3 × 8): 1
- Terminating resistor (110Ω): 1

CT-A-0005-A

## 7 LE7-ATT ATTACHMENT

The LE7-ATT attachment is used to mount the LE7-40GU-L on the panel.

An attachment is available for the LE-40MTA(-E), LE-40MTB(-E), and LE-30CTN(A).

### 7.1 External dimensions

#### Attachment

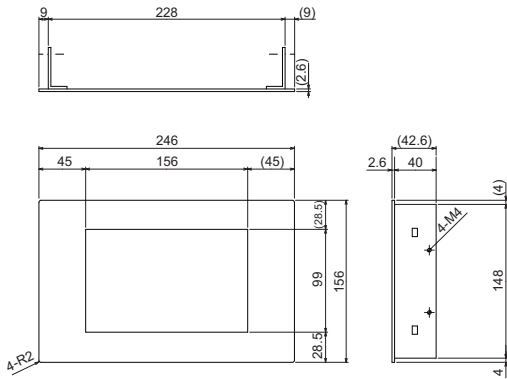

(Unit: mm)

#### Accessories

- Two plates for mounting the attachment: Used to fix the attachment on the control panel.
- Eight fixing screws (M4 × 10) for fixing the plates

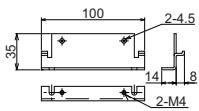

(Unit: mm)

CT-A-0005-A

---

**REVISIONS**

Version	Date of Issue	Revision
A	April 2021	First edition

**TRADEMARKS**

The company names, system names and product names mentioned in this technical bulletin are either registered trademarks or trademarks of their respective companies.

In some cases, trademark symbols such as <sup>™</sup> or <sup>®</sup> are not specified in this technical bulletin.